



# Re-Engineering Towed Arrays for Quality Enhancement - Network Based Towed Array

S. Anantha Narayanan<sup>1</sup>, V.P. Jagathy Raj<sup>2</sup>, S. Subash Subramoniam<sup>1</sup>, and  
M.G. Resmi<sup>1</sup>

<sup>1</sup>Naval Physical and Oceanographic Laboratory, Kochi 682 021, India.

<sup>2</sup>Cochin University of Science and Technology, Kochi 682 022, India.

ananth\_prathibha@yahoo.co.in, jagathy@cusat.ac.in

**Abstract**— The Towed Array electronics is a multi-channel simultaneous real time high speed data acquisition system. Since its assembly is highly manpower intensive, the costs of arrays are prohibitive and therefore any attempt to reduce the manufacturing, assembly, testing and maintenance costs is a welcome proposition. The Network Based Towed Array is an innovative concept and its implementation has remarkably simplified the fabrication, assembly and testing and revolutionised the Towed Array scenario. The focus of this paper is to give a good insight into the Reliability aspects of Network Based Towed Array. A case study of the comparison between the conventional array and the network based towed array is also dealt with.

**Index Terms**— Ethernet, Reliability, Towed Array

## 1. Introduction

Towed Array Sonar is a multi-channel mixed signal processing system, which receives radiated signals from multiple surface or sub-surface targets through an array of sensors distributed in a polyurethane tube to detect, track and localize the targets. It has the distinct advantage of functioning as variable depth sonar with a large aperture of a linear array operating at relatively lower frequency at ambient conditions free of self noise from own ship. The wet end of towed array consists of hydrophones, associated conditioning and telemetry electronics and their encapsulation to prevent physical contact with the water medium.

The hydrophones in the array pick up the pressure variations in the medium and convert

them into analog electrical signals. The signal conditioning electronics amplify these weak signals and makes them amenable to signal processing.

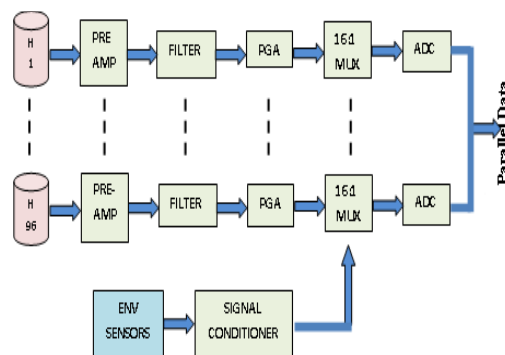

**Fig. 1: Signal conditioning electronics**

The towed array electronics digitizes the data, converts them into serial format and send it through the tow cable to the onboard electronics. Figure 1 represents the block diagram of towed array signal conditioning.

The conversion to serial format is done to reduce the number of interconnects in the tow cable. The importance of reduction in the number of wires in the tow cable cannot be overemphasized. A reduction in conductors means relaxation of requirement on the cable, the winch and the handling system.

## 2. Exploring the Potential of Ethernet for Towed Array

The Network Based Towed Array tries to take advantage of standard interfaces, miniaturization and the falling cost of electronics. The Ethernet Node forms the heart of the system.

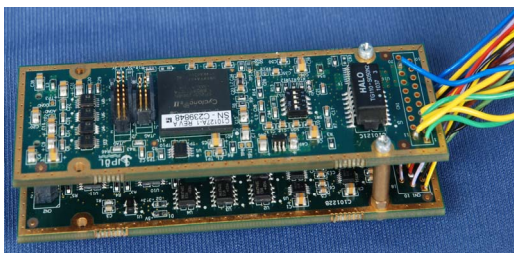

Fig. 2: Ethernet Node PCB

Each Node (figure 2) is capable of handling all the conditioning, digitization and serialization of its nearby sensors. The Node converts it to Ethernet. For increasing the numbers of channels all that is to be done is to increase the number of Nodes. The Ethernet packets from all the nodes are sent over the same serial bus as shown in figure 3.

Ethernet data transmission is not hard real time, therefore only the data acquisition is synchronized, not the packet transmission. Sampling synchronization is provided using a common clock signal for all the nodes. Each

node stores the data samples and transmits them as a larger block.

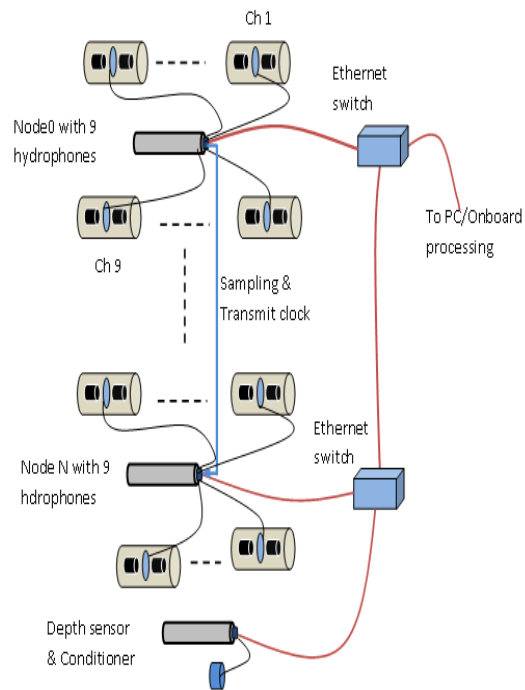

Fig. 3: Typical networked array configuration

## 3. Reliability Aspects of Network Based Towed Array

The innovative network based array could overcome the limitations of the existing arrays to a great extent. The areas where one can achieve considerable reliability advantages over conventional designs are detailed in the following sections.

### 3.1. Standardization of Protocol

During the initial phase of towed array development custom protocols were used for data telemetry. A serial protocol is best suited to transmit the data to onboard electronics since the number of wires inside the tow cable is limited. The best transmission medium for data over large distances is the optical fiber as explained in reference [3].

In Networked Array the data from each node will be in UDP over IP over Ethernet format at 10/100 Mbps, reference [1], [2]. There will be a time stamp so as to allow the receiver to put together the data from the same instant from all the sensors.

The conversion of the sensor data (not only acoustic but heading, roll, depth, temperature etc.) to Ethernet in Network based towed sensor array could be done with bare minimum PCBs. The adoption of this scheme will result in the standardization of all the critical data paths. The onboard front end electronics are also minimized. Interface testing can be done using standard packet monitoring software on an ordinary PC without requiring any sort of extra hardware.

### 3.2. Hardware Miniaturization

The existing conventional towed arrays had different PCBs for each task; i.e. one PCB for filtering, another for channel multiplexing, another for gain control, another for digitization, still another for parallel to serial data conversion etc as shown in figure 1. The electronics and interfaces between the modules were all custom-made; therefore each has its own problems.

The Ethernet node consists of a special form factor assembly of two PCBs (figure 2) that performs the analog amplification, filtering and digital conversion of up to 9 sets of hydrophones/channels. The node is based on ARM Cortex M3 and cyclone II FPGA with 9 ADCs along with amplifiers and filters.

### 3.3. Reduction in Wiring Density

The conventional array has to accommodate thousands of wire connections in a constrained area as in figure. 4.

Since the Ethernet node is kept close to hydrophone and interconnected serially through the Ethernet switches, the wire density is

reduced by more than 70 percent leading to less crosstalk and better SNR on all channels.

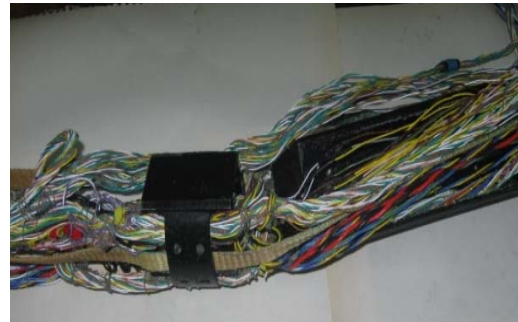

Fig. 4: Wiring complexity inside conventional arrays

### 3.4. Modularity

Since each capsule output is in Ethernet form, cascading of “ninelets” makes redesign of array into different length and array assembly relatively easier proposition. This also makes it possible to stock “ninelets” in multiple numbers to realise an array to specifications by combining them to arbitrary configurations with appropriate hydrophones as in figure 5.

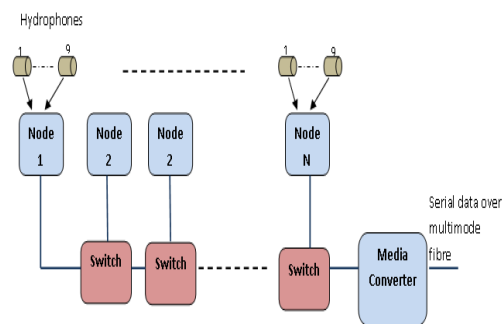

Fig. 5: Modular architecture of Network Based Towed Array

Made up of modules of 9 channels that can operated / tested independently, the number of channels may be increased or decreased without any hardware modification either in the towed array or in the onboard electronics.

### 3.5. Improvement in Signal Quality

As Towed array is a multi-channel mixed signal processing system, the signal integrity challenges faced are many. Signal integrity challenges are very well explained in reference [4]. The analog signals from the hydrophones are pre-amplified and received in the electronic module in analog form. Each of these modules was kept at a distance of about 60m to 70m which significantly affect the signal quality.

The network based design is expected to perform much better than conventional arrays because the digitization of the data happens much closer to the hydrophones. Also, separate ADCs are used for the individual channels to enable simultaneous sampling and reduce crosstalk. To reduce the pin count serial ADCs are used. The FPGA and the micro interface is 12 bit parallel to increase the throughput as the data from all 9 ADCs pass through this interface.

### 3.6. Maintainability

The maintainability of the pressure tolerant potted capsules (figure 6) in conventional arrays is virtually 'Nil' since the electronic components are not accessible even for trouble shooting. Whereas in networked array this hardware is kept inside a pressure tolerant metallic capsule (figure 7). The capsule is not potted and can be easily opened up permitting easy maintainability of the capsule electronics.



Fig. 6: Potted capsule (Conventional array)

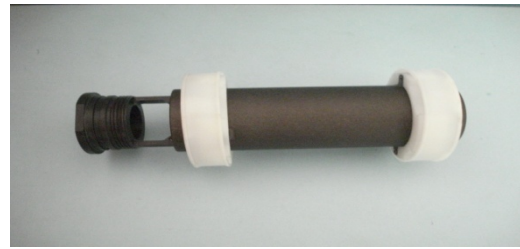

Fig. 7 : Pressure tolerant capsule for Node PCB

### 3.7. Effective Gain Control

It is also possible to provide control signals from onboard processor to the "Ninelet" through the Ethernet interface, a vital requirement for optimizing performance in real time.

Earlier these signals (AGC) have to travel a long way starting from the serialiser down to Passive signal conditioner PCB through a number of PCBs in between. The signal quality will have to be compromised in this context. Since the AGC is fed directly to the Node PCB there is no such issue in Network based array.

### 3.8. Reduction in Connector Pins

The electro-mechanical connectors interfacing two modules also affects the signal properties at high frequencies. The high frequency signals passing through the Electro-mechanical connectors (figure 8) produces stray electro-magnetic field and thereby affects the adjacent signals also.

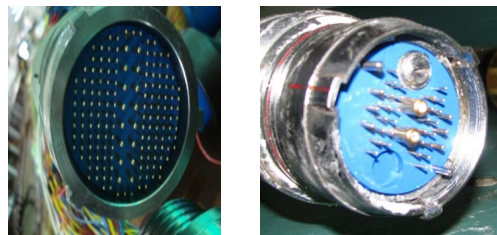

Fig. 8: EM connector interconnecting array modules (conventional vs. network based array)

Even a trace of oil present in the connector pins is degrading the quality of high speed signals. The reason for this is the variation in dielectric constant the signal sees due to the presence of the oil trace in the connector pins.

With the introduction of Network based array the number of pins in the connector came down to nearly 12%.

### 3.9. Testability

Testing of conventional array is done making use of custom test jigs or equipments, developed in house, right from the PCB level to the module level and the integrated level. With the introduction of a standard protocol based array only a PC or laptop is enough for testing the array. The packets can be directly captured by standard software like LabVIEW UDP read VI (virtual instrument), Wireshark, and Ethernet etc as shown in figure 9.

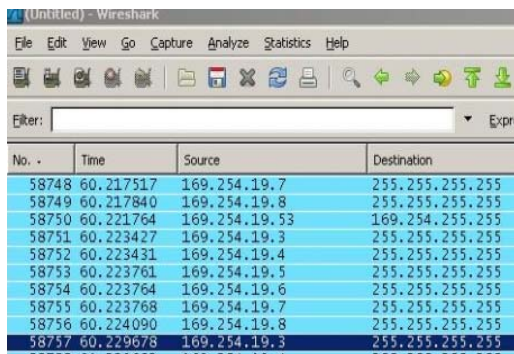

No. .	Time	Source	Destination
58748	60.217517	169.254.19.7	255.255.255.255
58749	60.217840	169.254.19.8	255.255.255.255
58750	60.221764	169.254.19.53	169.254.255.255
58751	60.223427	169.254.19.3	255.255.255.255
58752	60.223431	169.254.19.4	255.255.255.255
58753	60.223761	169.254.19.5	255.255.255.255
58754	60.223764	169.254.19.6	255.255.255.255
58755	60.223768	169.254.19.7	255.255.255.255
58756	60.224090	169.254.19.8	255.255.255.255
58757	60.229678	169.254.19.3	255.255.255.255

Fig. 9: Data captured in wireshark

### 3.10. Cost reduction

The array is likely to cost at least 30% less and the time of assembly is likely to get curtailed to half.

## 4. A case study

A comparison of Network Based towed array parameters with the conventional array both incorporating same number of

hydrophones (48 Nos) and same configuration is shown in figure 10. It is obvious that one could achieve better results in all the parameters listed in the case of network based array as in figure 10.

The existing telemetry scheme consists of 5 different types of PCBs (160mm x 53mm) so as to combine the data into the common data bus. In network based telemetry scheme a single PCB (100mm x 32mm) takes the raw sensor data and injects data packet into the network.

Wiring complexity has reduced substantially and the number of wires reduced by more than 70%. Signal quality is improved a lot with the noise reduced to 1/10<sup>th</sup>. A parallelism in wiring and assembly was also achieved with the modular architecture. This helped to curtail the assembly time to half.

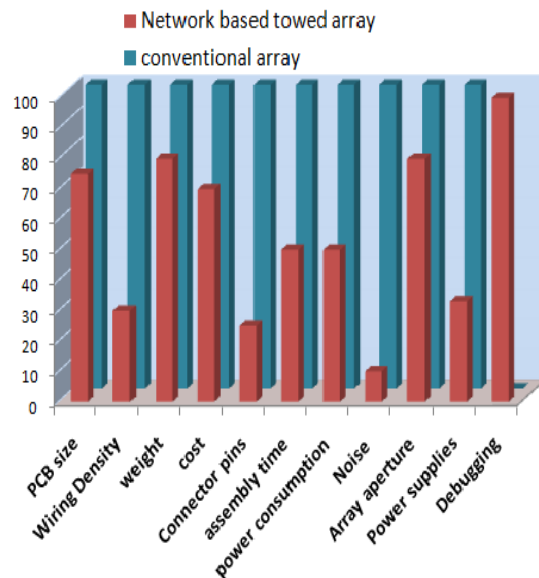

Fig. 10: Comparison between Networked array and conventional array parameters

Weight of the array was reduced to 80% of the conventional types. The connector pins are reduced to 1/5<sup>th</sup> in network array as compared

to conventional array having the same configuration.

Conventional arrays required  $\pm 15V$ ,  $\pm 5V$  and  $5V$  power supplies for powering the modules whereas in networked array,  $5V$  power supply will do. The array length also reduced from 20m to 16m in networked array.

The electronic capsules in the conventional arrays once potted can never be opened or debugged. The node PCB is encapsulated in a pressure tolerant capsule which can easily be opened, tested and debugged.

## 5. Conclusion

The Network Based Towed Array is a leap forward in terms of performance and reliability of towed arrays. The main criteria for the design of Network Based Towed Array are reduction in array internal wiring, modular architecture and ease of maintenance and testing. These factors help in reducing the realization time of the system. This is a direct benefit of moving to standard protocols for towed array telemetry. An otherwise cumbersome

and skilful job of array assembly has been upgraded to a professionally satisfying simpler job with less subjectivity on the skill of the worker in the shop floor. This will lead to repeatability in product and reliability in systems.

## References

- [1]. Johnson W. Howard 'Fast Ethernet: Dawn of a New Network'. Prentice Hall PTR, 1996
- [2]. Tanenbaum S. Andrew. 'Computer Networks'. 3rd Edition Prentice Hall of India, 2001
- [3]. Gibson D. Jerry. 'The communications handbook', CRC Press, 1997
- [4]. Hall H. Stephen, Hall W. Garret and McCall A. James 'High-Speed Digital System Design, A Handbook Of Interconnect Theory and Design Practices.