

Measurement of thermal diffusivity of some halogeno benzimidazole complexes of cobalt(II), copper (II) and copper(I) using laser induced photoacoustic effect

S. SANKARA RAMAN, V. P. N. NAMPOORI, C. P. G. VALLABHAN, N. SARAVANAN*,
 K. K. MOHAMMED YUSUFF*,

International School of Photonics and Department of Applied Chemistry*, Cochin University of Science and
 Technology, Cochin 682 022, Kerala, India

The photoacoustic (PA) effect is an effective method for obtaining information on the thermal and optical properties of materials [1-10]. The success of this new spectroscopic technique is mainly due to the fact that only the absorbed light contributes to the signal, giving a large signal to noise ratio. According to the Rosencwaig-Gersho theory [3], the primary source of the acoustic signal in the cell arises from the periodic heat flow from the solid to the coupling medium, as the solid is cyclically heated by the absorption of chopped light. The periodic flow of this heat into the coupling medium produces pressure fluctuations, which are detected as an acoustic signal by microphone at the modulation frequency, f . In this energy conversion (optical to acoustic), the thermal properties of the sample play a significant role. This suggests the possibility of using the PA effect for the study of thermal properties of solids such as the thermal diffusivity and specific heat capacity. A search through the literature reveals that very few PA studies have been carried out on metal complexes and that no work has been reported on benzimidazole complexes.

Complexes of benzimidazoles have attracted considerable attention in recent years. Benzimidazole derivatives have been reported to have antibacterial, antifungal, antiviral, antitumour, anticancer, anti-inflammatory, analgesic, antipyretic, antineoplastic, anthelmintic, germicidal and immuno-chemical agent activities. Complex compounds of transition metal ions with imidazole, benzimidazole and their substituted ligands have been studied extensively [11-15]. Recently, many low molecular weight complexes of Cu(II) containing imidazole ligand have been proposed as models of active sites of Cu proteins [16-18]. Incorporation of nitro groups in the azole compounds gives them anti-amoebic activity as well [19]. Some of the Co(II) and Cu(II) complexes reported have shown better catalytic activity, particularly in the synthetically important reaction of oxidation of substituted phenols, in which Co(II) and Cu(II) play a major role in catalysing these types of reactions. The structure of the ligand is shown in Fig. 1.

In this letter, we report thermal studies of 1-nitrobenzyl-2-nitrophenyl benzimidazole (NBPBI) complexes of Co(II), Cu(II) and Cu(I) by laser induced photoacoustic techniques.

The single-beam PA spectrometer assembled for

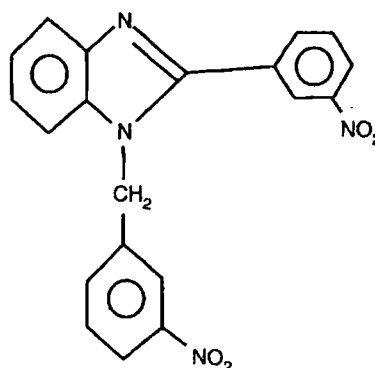

Figure 1 Structure of the ligand (NBPBI).

the investigation is shown in Fig. 2. The 488 nm line of the argon ion laser was used as the pump source. To generate an acoustic signal in the PA cell, the pump beam was modulated using an electromechanical chopper. The PA cell used was a cylindrical, small volume, non-resonant cell made of aluminium. The cell had an axial bore of about 0.5 cm diameter. One side of the bore was closed by a glass window and the sample was placed on the other side, then the cavity was closed tightly. To detect the acoustic signal generated in the coupling medium, a small highly sensitive microphone was kept close to the sample compartment in a separate port. The microphone output was processed by means of a lock-in amplifier.

The PA technique, which belongs to the periodic heat flow method, is an effective method for

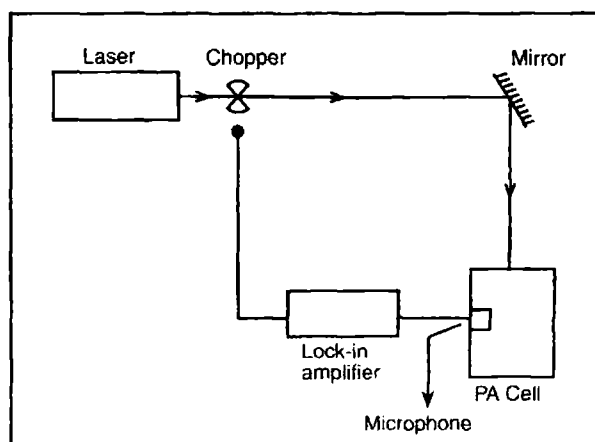

Figure 2 The single-beam PA spectrometer.

determining the thermal parameters. Here, the PA signal is measured as a function of chopping frequency. Charpentier *et al.* [9] have presented a frequency analysis of the PA signal for the determination of thermal diffusivity. For a given sample thickness, one can have a transition from a thermally thin regime to a thermally thick regime by increasing the chopping frequency, and this appears as a slope change at the characteristic frequency (f_c) in the log (amplitude) against log (frequency) plot. Knowing the actual thickness of the sample (l_s), the thermal diffusivity α can be calculated using the relation $\alpha = l_s^2 f_c$.

The thermogravimetric analysis showed that the sample did not decompose at temperatures lower than 280 °C. Hence, the exposure to the intensity modulated (chopped) laser beam of the power level used in the experiment (~100 mW) did not decompose the samples.

The experimental setup was standardized by determining the thermal diffusivity of copper and aluminium. The values obtained in the case of copper ($1.18 \text{ cm}^2 \text{ s}^{-1}$) and aluminium ($0.979 \text{ cm}^2 \text{ s}^{-1}$) agree well with the reported values of $1.16 \text{ cm}^2 \text{ s}^{-1}$ and $0.98 \text{ cm}^2 \text{ s}^{-1}$, respectively.

To determine the thermal diffusivity, the sample was pelletized under high pressure. Keeping the sample in the PA cell, the frequency dependence of the acoustic signal was studied. The variation of signal amplitude with frequency for CoL_2Cl_2 (where

$L = \text{NBPBI}$) is shown in Fig. 3. Determining the thickness of the sample and the characteristic frequency from the log-log plot of signal strength against chopping frequency, the thermal diffusivity can be calculated using the relation $\alpha = l_s^2 f_c$. The metal part of the complex (cobalt) was replaced by copper and the thermal diffusivities of CuL_2X_2 ($X = \text{Cl, Br, I}$) were also determined. The results obtained are given in Table I.

In the case of CoL_2X_2 , thermal diffusivity α increases in the order of $X = \text{Cl, Br, I}$, while the reverse was the case for CuL_2X_2 . Thus, the thermal diffusivity of the halogeno complexes depends on the metal part as well as on the halogen part. Detailed study of the phenomena is in progress.

In conclusion, the thermal diffusivity of CuL_2X_2 and CoL_2X_2 were determined by the PA technique and the effect of replacement of cobalt by copper on the thermal diffusivity of these complexes was examined. The thermal stability of these compounds was also studied.

Acknowledgements

The authors are grateful to the Department of Science and Technology (Government of India) for financial assistance. One of the authors (S.S.R.) is grateful to the Council of Scientific and Industrial Research, India, for a research fellowship.

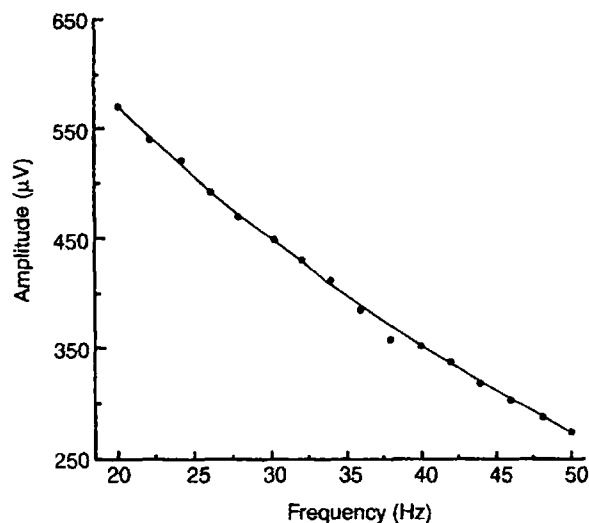

Figure 3 The variation of signal amplitude with frequency for CoL_2Cl_2 .

TABLE I Thermal diffusivities of Co(II), Cu(II) and Cu(I) halogeno benzimidazole complexes

Sample number	Sample	Thermal diffusivity ($\text{cm}^2 \text{ s}^{-1}$)
1	CoL_2Cl_2	0.1931
2	CoL_2Br_2	0.3831
3	CoL_2I_2	1.4090
4	CuL_2Cl_2	0.4579
5	CuL_2Br_2	0.2027
6	$\text{Cu}^{\text{I}}\text{L}_2\text{I}_2$	0.1885

References

1. A. G. BELL, *Amer. J. Sci.* **20** (1880) 305.
2. *Idem*, *Phil. Mag.* **11** (1881) 510.
3. A. ROSENCWAIG and A. GERSHO, *J. Appl. Phys.* **47** (1975) 64.
4. A. ROSENCWAIG, *Rev. Sci. Instrum.* **48** (1977) 1133.
5. G. C. WETSEL, JR and F. A. MACDONALD, *Appl. Phys. Lett.* **30** (1977) 252.
6. A. C. TAM, C. K. N. PATEL and R. J. KERL, *Opt. Lett.* **4** (1979) 81.
7. A. C. TAM, *Rev. Mod. Phys.* **56** (1986) 2.
8. C. L. CESAR, H. VRGAS and L. C. M. MIRANDA, *Appl. Phys. Lett.* **32** (1978) 554.
9. P. CHARPENTIER, F. LEPOUTRE and L. BERTRAND, *J. Appl. Phys.* **53** (1982) 1.
10. F. A. MACDONALD and G. C. WETSEL, JR, *ibid.* **49** (1978) 4.
11. S. P. GOSH, *J. Indian Chem. Soc.* **28** (1951) 710.
12. S. P. GOSH and H. M. GOSH, *ibid.* **33** (1956) 894.
13. G. GOODGAME and F. A. COTTON, *J. Amer. Chem. Soc.* **84** (1962) 1543.
14. D. M. L. GOODGAME and M. GOODGAME, *Inorg. Chem.* **4** (1965) 139.
15. J. REEDIJIK, *J. Inorg. Nucl. Chem.* **35** (1973) 239.
16. K. NAKAMOTO, "Infrared and Raman spectra of inorganic and coordination compounds", 3rd Edn (John Wiley, New York, 1978) p. 314.
17. J. R. DYER, "Applications of absorption spectroscopy of organic compounds" (Prentice Hall, Englewood Cliffs, New Jersey, 1965) p. 33.
18. B. J. HATHAWAY, *J. Chem. Soc., Dalton Trans.* (1972) 1196.
19. G. VASILEV and K. DAVARSKI, *Dokl. Bolg. Acad. Nauk.* **35** (1982) 1717.

Received 9 May