

Ph.D. Thesis

Studies on Structural Changes and Life Cycle Assessment in Mechanised Trawl Fishing Operations of Kerala

*Thesis submitted to the
Cochin University of Science and Technology
in partial fulfillment of the requirements for the award of the degree of
Doctor of Philosophy
in
Fisheries Science
under the Faculty of Marine Sciences*

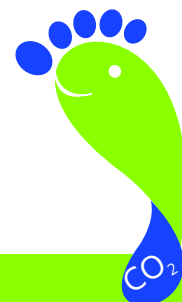

Renju Ravi
Reg. No. 3727



**ICAR- Central Institute of Fisheries Technology
Kochi- 682029**

December 2015

**Studies on Structural Changes and Life Cycle Assessment in
Mechanised Trawl Fishing Operations of Kerala**

*Thesis submitted to the
Cochin University of Science and Technology
in partial fulfillment of the requirements for the award of the degree of
Doctor of Philosophy
in
Fisheries Science
under the Faculty of Marine Sciences*

by
RENJU RAVI
(Reg. No. 3727)



CENTRAL INSTITUTE OF FISHERIES TECHNOLOGY
Indian Council of Agricultural Research
Kochi-682 029, INDIA



December 2015

Telephone : 0484-2412300
Fax : 0091-484-2668212

www.cift.res.in
E-mail : aris.cift@gmail.com
cift@ciftmail.org



भाकृअनुप - केन्द्रीय मात्स्यकी प्रौद्योगिकी संस्थान
ICAR - CENTRAL INSTITUTE OF FISHERIES TECHNOLOGY
सिफ्ट जंक्शन, विल्लिंडन आईलंड, मत्स्यपुरी पी.ओ., कोचिन, - 682 029, केरल, भारत।
CIFT Junction, Willingdon Island, Matsyapuri P.O., Cochin, - 682 029, Kerala, India.
(ISO/IEC 17025: 2005 Accredited & ISO 9001: 2008 Certified)



Certificate

*This is to certify that the thesis entitled “**Studies on Structural Changes and Life Cycle Assessment in Mechanised Trawl Fishing Operations of Kerala**” submitted by **Mr. Renju Ravi** (Reg. No. 3727) is an authentic record of research work carried out by him under my guidance and supervision at Central institute of Fisheries Technology, Kochi, Kerala in partial fulfillment of the requirement for the award of Ph.D. degree in the Faculty of Marine Sciences, Cochin University of Science and Technology, Kochi, Kerala and no part thereof has previously formed basis for the award of degree or associateship in any University or Institution. I further certify that all the relevant corrections and modifications suggested by the audience during the pre-synopsis seminar and recommended by the Doctoral Committee of the candidate have been incorporated in the thesis.*

Kochi-29
December 2015

Dr. Leela Edwin
(Supervising Guide)
Principal Scientist & Head
Fishing Technology Division
Central Institute of Fisheries Technology

Declaration

*I, Renju Ravi, do hereby declare that the thesis entitled “**Studies on Structural Changes and Life Cycle Assessment in Mechanised Trawl Fishing Operations of Kerala**” is a genuine record of research work carried out by me under the guidance of **Dr. Leela Edwin**, Head, Fishing Technology Division, Central Institute of Fisheries Technology, Kochi, Kerala in partial fulfillment for the award of Ph.D. degree under the Faculty of Marine Sciences, Cochin University of Science and Technology, Kochi, Kerala and no part thereof has previously formed the basis for the award of any degree, diploma, associateship, or any other title or recognition from any University or Institution.*

*Kochi-29
December 2015*

Renju Ravi

*This thesis is dedicated to all children of this World.
It is for them, we should think and act in a sustainable way!*

Acknowledgement

I would like to express my deep and sincere gratitude to my Supervising Guide Dr. Leela Edwin, Principal Scientist & Head, Fishing Technology Division, Central Institute of Fisheries Technology (CIFT), Kochi for the conceptualization of the topic, most valuable guidance, suggestions, consistent encouragement, motivation and support all the way through my doctoral research. Madam had supported me not only by providing research guidance over years, but also academically and emotionally through the rough road to completion of this thesis.

I owe a great deal of appreciation and gratitude to Dr. M.R. Boopendranath, Principal Scientist (Retd.), Fishing Technology Division, CIFT for his guidance, valuable suggestions and encouragement received during the doctoral programme. The encouragement, moral support, care and the freedom Sir had showered helped me a lot to overcome the hurdles even in my personal life.

I am grateful to Dr. C. N. Ravishankar, Director, CIFT, Kochi, Dr. T. K. Srinivasa Gopal (Former Director, CIFT) and Dr. B. Meenakumari (Former Director, CIFT & Deputy Director General – Fisheries, ICAR) for giving permission and the facilities provided, encouragement and constant support throughout the entire period of my study.

I am very much thankful to Dr. Girija S., Director, National Institute of Fisheries Post Harvest Technology & Training (NIFPHATT), Mr. Jai Singh Meena, Dy. Director, NIFPHATT and Mr. Varghese John, Marketing Officer, NIFPHATT for the unstinted support and encouragement given for the successful completion of my work.

I owe my sincere thanks to Dr. Saly N. Thomas, Principal Scientist, Fishing Technology Division, CIFT, Cochin and expert member of my Doctoral Committee, for the help rendered, fruitful suggestions and valuable contributions whenever required during the research work.

I sincerely acknowledge my deepest sense of gratitude to Dr. P. Pravin, Dr. M. P. Remesan and Dr. Muhammed Ashraf, Principal Scientists and Dr. V. R. Madhu and Mr. M. V. Baiju, Senior Scientists, Fishing Technology Division, CIFT, Kochi for their proficient advice, constructive criticism and constant encouragement.

I thank Dr. Peter Tyedmers, Professor and Director, School for Resource and Environmental Studies (SRES), Dalhousie University, Canada for his valuable suggestions, recommendations, support and advice which were very important factors for carrying out my work. I would like to thank Dr. Daniel Pauly, Professor & Principal Investigator, Sea Around Us Project, Institute for the Oceans and Fisheries, UBC Fisheries Centre, University of British Columbia; Dr. Reg Watson, Professor of Fisheries and Ecological Modelling, University of Tasmania, Institute for Marine and Antarctic Studies (IMAS), Australia; Dr. Friederike Ziegler, Senior Researcher, SP Technical Research Institute, Sweden and Dr. Villanueva-Rey P., Project Manager, NBC, Chile for providing their research articles and showering their good wishes.

I thankfully acknowledge Dean, Faculty of Marine Science and Director, School of Industrial Fisheries, CUSAT, for all the support provided in the smooth conduct of my research.

I warmly thank Mr. C. G. Joshi, Scientist, CIFT, Kochi for the excellent guidance in statistical analysis. I am greatly obliged to Mr. Rakesh Gaikwad and Mr. Ritesh Agarwal, PE-International for providing training and support in efficient use of GaBi-6 software. My best friend Mr. Dhiju Das P.H., CIFT had given me extensive support for the successful completion of my work.

I wish to acknowledge the contributions from Director, CMFRI, Head and Scientists from Fishery Resources Assessment Division of CMFRI, Chairman, MPEDA, Dy. Director, MPEDA Regional Office, Kochi and officers of Kerala State Fisheries Department during the study. I sincerely thank the officials of fishery harbours, fishermen, net makers, vessel builders and vessel operators for their kind support and cooperation in the procurement of relevant data, for the smooth conduct of the research work. The enthusiastic cooperation received from the fishermen, during the conduct of the study will be remembered.

I wish to express my sincere thanks to National Agricultural Science Fund (NASF) (ICAR) for providing the fellowship under the project "Green Fishing Systems for Tropical Seas".

I am indebted to Dr. Suseela Mathew, Principal Scientist and Head of Division (Biochemistry) and Ph.D. Cell (I/C), CIFT for the timely help in all matters concerned with my

Ph.D. programme. The help and support extended by the Ph.D. Cell staff are greatly acknowledged.

I thank all staff of CIFT, especially in the Fishing Technology Division and Library, for their courteous assistance and support throughout the study period.

I thank all staff of NIFPHATT especially from Marketing Section for the help and cooperation extended.

I thankfully acknowledge all teaching and non-teaching staff members of School of Industrial Fisheries, CUSAT, Cochin.

I fondly cherish the love, care and support of my good friends, Dr. Gibin Kumar T.R., Dr. Sabu S., Dr. Gipson Edappazham, Mr. Vipin P. M., Mr. Shaju S. S., Mr. Pradip Kumar Mahato, Mr. Muhammed Sherief P. S., Dr. Aneesh Kumar K.V., Mr. K.A. Joseph Ralie, Mr. Rithin Joseph, Mr. Sreejith P.T., Mr. T. Jose Fernandez, Mr. K. Pradeep, Ms. Sayana K.A., Ms. Minu P., Ms. Souda V.P., Mr. Vipin Kumar V., Mr. Kiran V.R., Mr. Jinu K., Mr. Asish H. Nair, Ms. Jolsana J., Mr. Unnikrishnan H., Mr. James J. P., Ms. Manju and Ms. Raseena.

The support of my family has been unconditional all these years and without their encouragement, prayers and understanding it would have been impossible for me to finish this work. I sincerely thank all my family members and relatives, especially my father, mother, wife, two daughters and my brother for their love and encouragement.

Thanks are also due to all those who have not been mentioned by name but nevertheless have been of invaluable help in their inscrutable ways.

Renju Ravi

Contents

Chapter-1	Introduction-----	1-30
1.1	World fisheries-----	1
1.2	Indian fisheries-----	3
1.3	Kerala fisheries-----	7
1.4	Energy consumption in fisheries -----	8
1.5	Impact of energy use in environment-----	17
1.6	Life cycle assessment and carbon footprint studies in fisheries---	18
1.7	Energy conservation in fisheries -----	23
1.8	Scope of the study -----	28
1.9	Objectives -----	30
Chapter-2	Materials and Methods-----	31-47
2.1	Study area-----	31
2.2	Structural changes in trawlers -----	31
2.3	Life cycle assessment and carbon footprint -----	32
2.3.1	Global warming potential-----	34
2.3.2	Abiotic depletion potential-----	34
2.3.3	Acidification potential-----	35
2.3.4	Eutrophication potential-----	35
2.3.5	Marine aquatic ecotoxicity potential-----	35
2.3.6	Ozone layer depletion potential -----	36
2.3.7	Photochemical ozone creation potential-----	36
2.3.8	Data sources for life cycle assessment and carbon footprint -----	37
2.3.8.1	Fishing vessels-----	37
2.3.8.2	Fishing gear-----	39
2.3.8.3	Operational details-----	40
Chapter-3	Structural Changes in the Trawl Fishing Systems ----	48-56
3.1	Introduction-----	48

3.2	<i>Materials and methods</i>	49
3.3	<i>Results</i>	49
3.3.1	<i>Frequency distribution in length classes</i>	51
3.3.2	<i>Frequency distribution in installed engine horsepower</i>	52
3.3.3	<i>Relationship between length and engine horsepower of trawlers</i>	53
3.3.4	<i>Frequency distribution of makes of engines</i>	53
3.4	<i>Discussion</i>	54
3.5	<i>Conclusion</i>	56
Chapter- 4	<i>Life Cycle Assessment and Carbon Footprint of Trawlers</i>	57-157
4.1	<i>Introduction</i>	57
4.2	<i>Materials and methods</i>	58
4.3	<i>Results</i>	61
4.3.1	<i>Trawlers of Kerala</i>	61
4.3.1.1	<i>Small trawlers</i>	63
4.3.1.2	<i>Medium trawlers</i>	64
4.3.1.3	<i>Large trawlers</i>	65
4.3.1.4	<i>Very large trawlers</i>	67
4.3.2	<i>Power and propulsion</i>	69
4.3.3	<i>Trawl winch</i>	70
4.3.4	<i>Electronic navigation, fish finding and communication equipment</i>	71
4.3.5	<i>Otterboards</i>	72
4.3.6	<i>Life cycle inventory</i>	75
4.3.7	<i>Life cycle impact assessment</i>	76
4.3.7.1	<i>Global warming potential</i>	77
4.3.7.2	<i>Abiotic depletion potential (fossil)</i>	87
4.3.7.3	<i>Acidification potential</i>	97
4.3.7.4	<i>Eutrophication potential</i>	107

	4.3.7.5	Marine aquatic ecotoxicity potential	117
	4.3.7.6	Ozone depletion potential	127
	4.3.7.7	Photochemical ozone creation potential	137
	4.4	Discussion	147
	4.5	Conclusion	157
Chapter-5		<i>Life Cycle Assessment and Carbon Footprint of Trawl Gear Systems</i>	158-202
	5.1	Introduction	158
	5.2	Materials and methods	160
	5.3	Results	161
	5.3.1	Trawl nets	162
	5.3.1.1	Fish trawls	164
	5.3.1.2	Cephalopod trawls	164
	5.3.1.3	Shrimp trawls	165
	5.3.2	Life cycle inventory	181
	5.3.3	Life cycle impact assessment	182
	5.3.3.1	Global warming potential	182
	5.3.3.2	Abiotic depletion potential (fossil)	184
	5.3.3.3	Acidification potential	186
	5.3.3.4	Eutrophication potential	188
	5.3.3.5	Marine aquatic ecotoxicity potential	190
	5.3.3.6	Ozone depletion potential	192
	5.3.3.7	Photochemical ozone creation potential	194
	5.4	Discussion	196
	5.5	Conclusion	201
Chapter-6		<i>Life Cycle Assessment and Carbon Footprint of Trawl Landings</i>	203-243
	6.1	Introduction	203
	6.2	Trawl caught species	204
	6.3	Materials and methods	207

6.4	<i>Results</i> -----	211
6.4.1	<i>Life cycle inventory</i> -----	211
6.4.2	<i>Life cycle impact assessment</i> -----	214
6.4.2.1	<i>Global warming potential</i> -----	214
6.4.2.2	<i>Abiotic depletion potential (fossil)</i> -----	217
6.4.2.3	<i>Acidification potential</i> -----	220
6.4.2.4	<i>Eutrophication potential</i> -----	223
6.4.2.5	<i>Marine aquatic ecotoxicity potential</i> -----	226
6.4.2.6	<i>Ozone depletion potential</i> -----	229
6.4.2.7	<i>Photochemical ozone creation potential</i> -----	232
6.4.3	<i>Estimates of impact category values per tonne of marine fish landed</i> -----	235
6.5	<i>Discussion</i> -----	236
6.6	<i>Conclusion</i> -----	242
Chapter-7	<i>Hotspots and Approaches to Reduce Environmental Impacts of the Trawl Fisheries</i> -----	244-254
7.1	<i>Introduction</i> -----	244
7.2	<i>Hotspots identified in trawler construction and maintenance</i> ---	245
7.3	<i>Hotspots identified in trawl net construction and maintenance</i> --	246
7.4	<i>Hotspots identified in trawling operations</i> -----	247
7.5	<i>Fuel consumption in mechanised trawling operations</i> -----	249
7.6	<i>Approaches to reduce environmental impacts of the trawl fisheries</i> -----	251
7.7	<i>Conclusion</i> -----	254
Chapter-8	<i>Summary and Recommendations</i> -----	255-262
	<i>References</i> -----	263-301
	<i>Publications</i> -----	302-314

List of Figures

No.	Title	Page No.
Fig. 1.1	Trend in global marine capture fishery production-----	3
Fig. 1.2	Global trends in the state of marine fish stocks during 1974-2011 -----	3
Fig. 1.3	Present fleet size and estimated optimum fleet size for marine fisheries of India -----	6
Fig. 1.4	Increase of price in diesel in the last 25 years-----	16
Fig. 1.5	Vicious cycle of increasing effort, decreasing landings and increasing GHG emissions, in fisheries-----	18
Fig. 2.1	Landing areas selected for the study -----	32
Fig. 2.2	System boundaries for life cycle assessment of mechanised trawl fishing operations -----	37
Fig. 3.1	Increase in number of mechanised trawlers, other mechanised vessels and total marine fishing fleet in Kerala during 1980-2010 -----	50
Fig. 3.2	Frequency distribution of length classes of trawlers in Kerala-----	51
Fig. 3.3	Frequency distribution of installed horsepower of trawlers in Kerala -----	52
Fig. 3.4	Relationship between length and engine horsepower of trawlers during 2012 -----	53
Fig. 3.5	Frequency distribution of different types of engines installed in trawlers operating from Kerala, during 2012-----	54
Fig. 4.1	Material inputs to fishing vessel construction and maintenance-----	60
Fig. 4.2	Construction of a steel trawler -----	62
Fig. 4.3	Construction of a wooden trawler -----	63
Fig. 4.4	View of a small wooden trawler -----	64
Fig. 4.5	A medium sized trawler-----	65
Fig. 4.6	A large steel trawler -----	65
Fig. 4.7	Profile and deck layout of a large trawler-----	66
Fig. 4.8	A very large steel trawler -----	67
Fig. 4.9	Profile and deck layout of a very large trawler-----	68
Fig. 4.10	Three blade propellers used in trawlers-----	70
Fig. 4.11	Net drums used in a very large trawler in Kochi-----	71
Fig. 4.12	Design of a typical V-form steel otterboard-----	73
Fig. 4.13	V-form steel otterboards onboard a trawler-----	74
Fig. 4.14	Wooden flat rectangular otterboards-----	74

Fig. 4.15	<i>Global warming potential of 10.66 m small wooden single-day trawler</i>	77
Fig. 4.16	<i>Global warming potential of 13.71 m medium wooden multi-day trawler</i>	78
Fig. 4.17	<i>Global warming potential of 15.3 m medium wooden multi-day trawler</i>	79
Fig. 4.18	<i>Global warming potential of 18.9 m large wooden multi-day trawler</i>	79
Fig. 4.19	<i>Global warming potential of 19.81 m large wooden multi-day trawler</i>	80
Fig. 4.20	<i>Global warming potential of 21.33 m large wooden multi-day trawler</i>	81
Fig. 4.21	<i>Global warming potential of 13.71 m medium steel multi-day trawler</i>	81
Fig. 4.22	<i>Global warming potential of 15.3 m medium steel multi-day trawler</i>	82
Fig. 4.23	<i>Global warming potential of 18.9 m large steel multi-day trawler</i>	83
Fig. 4.24	<i>Global warming potential of 19.81 m large steel multi-day trawler</i>	83
Fig. 4.25	<i>Global warming potential of 21.33 m large steel multi-day trawler</i>	84
Fig. 4.26	<i>Global warming potential of 22.86 m large steel multi-day trawler</i>	85
Fig. 4.27	<i>Global warming potential of 24.38 m very large steel multi-day trawler</i>	85
Fig. 4.28	<i>Global warming potential of 25.9 m very large steel multi-day trawler</i>	86
Fig. 4.29	<i>Global warming potential of 27.43 m very large steel multi-day trawler</i>	87
Fig. 4.30	<i>Abiotic depletion potential of 10.66 m small wooden single-day trawler</i>	87
Fig. 4.31	<i>Abiotic depletion potential of 13.71 m medium wooden multi-day trawler</i>	88
Fig. 4.32	<i>Abiotic depletion potential of 15.3 m medium wooden multi-day trawler</i>	89
Fig. 4.33	<i>Abiotic depletion potential of 18.9 m large wooden multi-day trawler</i>	89
Fig. 4.34	<i>Abiotic depletion potential of 19.81 m large wooden multi-day trawler</i>	90
Fig. 4.35	<i>Abiotic depletion potential of 21.33 m large wooden multi-day trawler</i>	91

Fig. 4.36	<i>Abiotic depletion potential of 13.71 m medium steel multi-day trawler</i>	91
Fig. 4.37	<i>Abiotic depletion potential of 15.3 m medium steel multi-day trawler</i>	92
Fig. 4.38	<i>Abiotic depletion potential of 18.9 m large steel multi-day trawler</i>	93
Fig. 4.39	<i>Abiotic depletion potential of 19.81 m large steel multi-day trawler</i>	93
Fig. 4.40	<i>Abiotic depletion potential of 21.33 m large steel multi-day trawler</i>	94
Fig. 4.41	<i>Abiotic depletion potential of 22.86 m large steel multi-day trawler</i>	95
Fig. 4.42	<i>Abiotic depletion potential of 24.38 m very large steel multi-day trawler</i>	95
Fig. 4.43	<i>Abiotic depletion potential of 25.9 m very large steel multi-day trawler</i>	96
Fig. 4.44	<i>Abiotic depletion potential of 27.43 m very large steel multi-day trawler</i>	97
Fig. 4.45	<i>Acidification potential of 10.66 m small wooden single-day trawler</i>	97
Fig. 4.46	<i>Acidification potential of 13.71 m medium wooden multi-day trawler</i>	98
Fig. 4.47	<i>Acidification potential of 15.3 m medium wooden multi-day trawler</i>	99
Fig. 4.48	<i>Acidification potential of 18.9 m large wooden multi-day trawler</i>	99
Fig. 4.49	<i>Acidification potential of 19.81 m large wooden multi-day trawler</i>	100
Fig. 4.50	<i>Acidification potential of 21.33 m large wooden multi-day trawler</i>	101
Fig. 4.51	<i>Acidification potential of 13.71 m medium steel multi-day trawler</i>	101
Fig. 4.52	<i>Acidification potential of 15.3 m medium steel multi-day trawler</i>	102
Fig. 4.53	<i>Acidification potential of 18.9 m large steel multi-day trawler</i>	103
Fig. 4.54	<i>Acidification potential of 19.81 m large steel multi-day trawler</i>	103
Fig. 4.55	<i>Acidification potential of 21.33 m large steel multi-day trawler</i>	104
Fig. 4.56	<i>Acidification potential of 22.86 m large steel multi-day trawler</i>	105
Fig. 4.57	<i>Acidification potential of 24.38 m very large steel multi-day trawler</i>	105
Fig. 4.58	<i>Acidification potential of 25.9 m very large steel multi-day trawler</i>	106
Fig. 4.59	<i>Acidification potential of 27.43 m very large steel multi-day trawler</i>	107
Fig. 4.60	<i>Eutrophication potential of 10.66 m small wooden single-day trawler</i>	107
Fig. 4.61	<i>Eutrophication potential of 13.71 m medium wooden multi-day trawler</i>	108

Fig. 4.62	<i>Eutrophication potential of 15.3 m medium wooden multi-day trawler</i> -----	109
Fig. 4.63	<i>Eutrophication potential of 18.9 m large wooden multi-day trawler</i> -----	109
Fig. 4.64	<i>Eutrophication potential of 19.81 m large wooden multi-day trawler</i> -----	110
Fig. 4.65	<i>Eutrophication potential of 21.33 m large wooden multi-day trawler</i> -----	111
Fig. 4.66	<i>Eutrophication potential of 13.71 m medium steel multi-day trawler</i> -----	111
Fig. 4.67	<i>Eutrophication potential of 15.3 m medium steel multi-day trawler</i> ----	112
Fig. 4.68	<i>Eutrophication potential of 18.9 m large steel multi-day trawler</i> ----	113
Fig. 4.69	<i>Eutrophication potential of 19.81 m large steel multi-day trawler</i> ----	113
Fig. 4.70	<i>Eutrophication potential of 21.33 m large steel multi-day trawler</i> ----	114
Fig. 4.71	<i>Eutrophication potential of 22.86 m large steel multi-day trawler</i> ----	115
Fig. 4.72	<i>Eutrophication potential of 24.38 m very large steel multi-day trawler</i> -----	115
Fig. 4.73	<i>Eutrophication potential of 25.9 m very large steel multi-day trawler</i> -----	116
Fig. 4.74	<i>Eutrophication potential of 27.43 m very large steel multi-day trawler</i> -----	117
Fig. 4.75	<i>Marine aquatic ecotoxicity potential of 10.66 m small wooden single-day trawler</i> -----	117
Fig. 4.76	<i>Marine aquatic ecotoxicity potential of 13.71 m medium wooden multi-day trawler</i> -----	118
Fig. 4.77	<i>Marine aquatic ecotoxicity potential of 15.3 m medium wooden multi-day trawler</i> -----	119
Fig. 4.78	<i>Marine aquatic ecotoxicity potential of 18.9 m large wooden multi-day trawler</i> -----	119
Fig. 4.79	<i>Marine aquatic ecotoxicity potential of 19.81 m large wooden multi-day trawler</i> -----	120
Fig. 4.80	<i>Marine aquatic ecotoxicity potential of 21.33 m large wooden multi-day trawler</i> -----	121
Fig. 4.81	<i>Marine aquatic ecotoxicity potential of 13.71 m medium steel multi-day trawler</i> -----	121
Fig. 4.82	<i>Marine aquatic ecotoxicity potential of 15.3 m medium steel multi-day trawler</i> -----	122
Fig. 4.83	<i>Marine aquatic ecotoxicity potential of 18.9 m large steel multi-day trawler</i> -----	123

Fig. 4.84	<i>Marine aquatic ecotoxicity potential of 19.81 m large steel multi-day trawler</i> -----	123
Fig. 4.85	<i>Marine aquatic ecotoxicity potential of 21.33 m large steel multi-day trawler</i> -----	124
Fig. 4.86	<i>Marine aquatic ecotoxicity potential of 22.86 m large steel multi-day trawler</i> -----	125
Fig. 4.87	<i>Marine aquatic ecotoxicity potential of 24.38 m very large steel multi-day trawler</i> -----	125
Fig. 4.88	<i>Marine aquatic ecotoxicity potential of 25.9 m very large steel multi-day trawler</i> -----	126
Fig. 4.89	<i>Marine aquatic ecotoxicity potential of 27.43 m very large steel multi-day trawler</i> -----	127
Fig. 4.90	<i>Ozone depletion potential of 10.66 m small wooden single-day trawler</i> -----	127
Fig. 4.91	<i>Ozone depletion potential of 13.71 m medium wooden multi-day trawler</i> -----	128
Fig. 4.92	<i>Ozone depletion potential of 15.3 m medium wooden multi-day trawler</i> -----	129
Fig. 4.93	<i>Ozone depletion potential of 18.9 m large wooden multi-day trawler</i> -----	129
Fig. 4.94	<i>Ozone depletion potential of 19.81 m large wooden multi-day trawler</i> -----	130
Fig. 4.95	<i>Ozone depletion potential of 21.33 m large wooden multi-day trawler</i> -----	131
Fig. 4.96	<i>Ozone depletion potential of 13.71 m medium steel multi-day trawler</i> -----	131
Fig. 4.97	<i>Ozone depletion potential of 15.3 m medium steel multi-day trawler</i> -----	132
Fig. 4.98	<i>Ozone depletion potential of 18.9 m large steel multi-day trawler</i> -----	133
Fig. 4.99	<i>Ozone depletion potential of 19.81 m large steel multi-day trawler</i> -----	133
Fig. 4.100	<i>Ozone depletion potential of 21.33 m large steel multi-day trawler</i> -----	134
Fig. 4.101	<i>Ozone depletion potential of 22.86 m large steel multi-day trawler</i> -----	135
Fig. 4.102	<i>Ozone depletion potential of 24.38 m very large steel multi-day trawler</i> -----	135
Fig. 4.103	<i>Ozone depletion potential of 25.9 m very large steel multi-day trawler</i> -----	136
Fig. 4.104	<i>Ozone depletion potential of 27.43 m very large steel multi-day trawler</i> -----	137

Fig. 4.105	<i>Photochemical ozone creation potential of 10.66 m small wooden single-day trawler</i>	137
Fig. 4.106	<i>Photochemical ozone creation potential of 13.71 m medium wooden multi-day trawler</i>	138
Fig. 4.107	<i>Photochemical ozone creation potential of 15.3 m medium wooden multi-day trawler</i>	139
Fig. 4.108	<i>Photochemical ozone creation potential of 18.9 m large wooden multi-day trawler</i>	139
Fig. 4.109	<i>Photochemical ozone creation potential of 19.81 m large wooden multi-day trawler</i>	140
Fig. 4.110	<i>Photochemical ozone creation potential of 21.33 m large wooden multi-day trawler</i>	141
Fig. 4.111	<i>Photochemical ozone creation potential of 13.71 m medium steel multi-day trawler</i>	141
Fig. 4.112	<i>Photochemical ozone creation potential of 15.3 m medium steel multi-day trawler</i>	142
Fig. 4.113	<i>Photochemical ozone creation potential of 18.9 m large steel multi-day trawler</i>	143
Fig. 4.114	<i>Photochemical ozone creation potential of 19.81 m large steel multi-day trawler</i>	143
Fig. 4.115	<i>Photochemical ozone creation potential of 21.33 m large steel multi-day trawler</i>	144
Fig. 4.116	<i>Photochemical ozone creation potential of 22.86 m large steel multi-day trawler</i>	145
Fig. 4.117	<i>Photochemical ozone creation potential of 24.38 m very large steel multi-day trawler</i>	145
Fig. 4.118	<i>Photochemical ozone creation potential of 25.9 m very large steel multi-day trawler</i>	146
Fig. 4.119	<i>Photochemical ozone creation potential of 27.43 m very large steel multi-day trawler</i>	147
Fig. 4.120	<i>Global warming potential from different trawlers</i>	148
Fig. 4.121	<i>Abiotic depletion potential (fossil) from different trawlers</i>	149
Fig. 4.122	<i>Acidification potential from different trawlers</i>	151
Fig. 4.123	<i>Eutrophication potential from different trawlers</i>	152
Fig. 4.124	<i>Marine aquatic ecotoxicity potential from different trawlers</i>	153
Fig. 4.125	<i>Ozone depletion potential from different trawlers</i>	155
Fig. 4.126	<i>Photochemical ozone creation potential from different trawlers</i>	156
Fig. 5.1	<i>Classification of trawls</i>	158

Fig. 5.2	Structure of a typical trawl net -----	159
Fig. 5.3	Material inputs to trawl net construction and maintenance -----	161
Fig. 5.4	Construction of a trawl net at Munambam-----	163
Fig. 5.5	Measurement of design details of a trawl net at Kasaragod-----	163
Fig. 5.6	Design of 39.6 m fish trawl-----	166
Fig. 5.7	Design of 53.8 m fish trawl-----	167
Fig. 5.8	Design of 72.0 m fish trawl-----	168
Fig. 5.9	Design of 76.5 m fish trawl-----	169
Fig. 5.10	Design of 81.0 m fish trawl-----	170
Fig. 5.11	Design of 85.6 m fish trawl-----	171
Fig. 5.12	Design of 33.4 m cephalopod trawl-----	172
Fig. 5.13	Design of 45.6 m cephalopod trawl-----	173
Fig. 5.14	Design of 54.0 m cephalopod trawl-----	174
Fig. 5.15	Design of 57.6 m cephalopod trawl-----	175
Fig. 5.16	Design of 34.2 m shrimp trawl -----	176
Fig. 5.17	Design of 39.6 m shrimp trawl -----	177
Fig. 5.18	Design of 40.0 m shrimp trawl -----	178
Fig. 5.19	Design of 51.0 m shrimp trawl -----	179
Fig. 5.20	Design of 58.0 m shrimp trawl -----	180
Fig. 5.21	Global warming potential from different trawl nets -----	184
Fig. 5.22	Abiotic depletion potential (fossil) from different trawl nets-----	186
Fig. 5.23	Acidification potential from different trawl nets-----	188
Fig. 5.24	Eutrophication potential from different trawl nets -----	190
Fig. 5.25	Marine aquatic ecotoxicity potential from different trawl nets-----	192
Fig. 5.26	Ozone depletion potential from different trawl nets -----	194
Fig. 5.27	Photochemical ozone creation potential from different trawl nets -----	196
Fig. 6.1	Estimated marine fish landings (month-wise) in Kerala in single-day trawl and multi-day trawl during June 2012 - May 2013 (in tonnes) -----	207
Fig. 6.2	Material inputs for mechanised trawling-----	211
Fig. 6.3	Global warming potential for trawler operations, for different size categories -----	216
Fig. 6.4	Abiotic depletion potential (fossil) for trawler operations, for different size categories -----	219
Fig. 6.5	Acidification potential for trawler operations, for different size categories -----	222

Fig. 6.6	<i>Eutrophication potential for trawler operations, for different size categories</i> -----	225
Fig. 6.7	<i>Marine aquatic ecotoxicity potential for trawler operations, for different size categories</i> -----	228
Fig. 6.8	<i>Ozone depletion potential for trawler operations, for different size categories</i> -----	231
Fig. 6.9	<i>Photochemical ozone creation potential for trawler operations, for different size categories</i> -----	234

List of Tables

<i>No.</i>	<i>Title</i>	<i>Page No.</i>
Table 1.1:	Comparison of fuel consumption ($\text{kg fuel kg fish}^{-1}$) in different trawl fisheries-----	13
Table 1.2:	Comparison of energy intensity in commercial fisheries-----	15
Table 1.3:	LCA and related studies in world fisheries-----	22
Table 1.4:	Major craft-gear combinations in the mechanised fishing sector of Kerala-----	29
Table 1.5:	Mechanised fishing fleet in Kerala-----	29
Table 2.1:	Different categories of trawlers-----	38
Table 4.1:	Classification of trawlers based on L_{OA} -----	58
Table 4.2:	Propeller weight vs L_{OA} of trawlers-----	69
Table 4.3:	Life cycle inventory of wooden trawlers (Fishing sub-system 1)-----	75
Table 4.4:	Life cycle inventory of steel trawlers (Fishing sub-system 1)-----	76
Table 4.5:	Comparison of global warming potential from different trawlers-----	148
Table 4.6:	Comparison of abiotic depletion potential (fossil) from different trawlers-----	150
Table 4.7:	Comparison of acidification potential from different trawlers-----	151
Table 4.8:	Comparison of eutrophication potential from different trawlers-----	152
Table 4.9:	Comparison of marine aquatic ecotoxicity potential from different trawlers-----	154
Table 4.10:	Comparison of ozone layer depletion potential from different trawlers-----	155
Table 4.11:	Comparison of photochemical ozone creation potential from different trawlers-----	156
Table 5.1:	Size ranges of trawl nets based on target groups-----	162
Table 5.2:	Life cycle inventory of trawl nets (Fishing sub-system 2)-----	181
Table 5.3:	Comparison of global warming potential from different trawl nets--	197
Table 5.4:	Comparison of abiotic depletion potential (fossil) from different trawl nets-----	197
Table 5.5:	Comparison of acidification potential from different trawl nets-----	198

<i>Table 5.6:</i>	<i>Comparison of eutrophication potential from different trawl nets ---</i>	<i>199</i>
<i>Table 5.7:</i>	<i>Comparison of marine aquatic ecotoxicity potential from different trawl nets-----</i>	<i>199</i>
<i>Table 5.8:</i>	<i>Comparison of ozone depletion potential from different trawl nets--</i>	<i>200</i>
<i>Table 5.9:</i>	<i>Comparison of photochemical ozone creation potential from different trawl nets-----</i>	<i>201</i>
<i>Table 6.1:</i>	<i>Estimated marine fish landings in Kerala in single-day trawl and multi-day trawl during June 2012 - May 2013 (in tonnes)-----</i>	<i>205</i>
<i>Table 6.2:</i>	<i>Life cycle inventory of trawling operations by wooden vessels per year -----</i>	<i>212</i>
<i>Table 6.3:</i>	<i>Life cycle inventory of trawling operations by steel vessels per year -</i>	<i>212</i>
<i>Table 6.4:</i>	<i>Estimates of fleet size, trip per year and unit operations of single-day and multi-day trawler fleets-----</i>	<i>213</i>
<i>Table 6.5:</i>	<i>Global warming potential (GWP 100 years) in single-day and multi-day trawler sectors in Kerala-----</i>	<i>217</i>
<i>Table 6.6:</i>	<i>Abiotic depletion potential (fossil) in single-day and multi-day trawler sectors in Kerala-----</i>	<i>220</i>
<i>Table 6.7:</i>	<i>Acidification potential in single-day and multi-day trawler sectors in Kerala-----</i>	<i>223</i>
<i>Table 6.8:</i>	<i>Eutrophication potential in single-day and multi-day trawler sectors in Kerala-----</i>	<i>226</i>
<i>Table 6.9:</i>	<i>Marine aquatic ecotoxicity potential in single-day and multi-day trawler sectors in Kerala-----</i>	<i>229</i>
<i>Table 6.10:</i>	<i>Ozone depletion potential in single-day and multi-day trawler sectors in Kerala-----</i>	<i>232</i>
<i>Table 6.11:</i>	<i>Photochemical ozone creation potential in single-day and multi-day trawler sectors in Kerala-----</i>	<i>235</i>
<i>Table 6.12:</i>	<i>Estimates of impact category values per tonne of marine fish landed during trawling operations in Kerala -----</i>	<i>236</i>
<i>Table: 7.1.</i>	<i>Marine fish production of Kerala during the last three years-----</i>	<i>245</i>

List of Annexures

<i>No.</i>	<i>Title</i>	<i>Page No.</i>
<i>Annexure I</i>	<i>Details of fishing craft and gear</i> -----	<i>43</i>
<i>Annexure II</i>	<i>Details of material inputs into construction of mechanised trawler</i> -	<i>45</i>
<i>Annexure III</i>	<i>Trawl net template</i> -----	<i>46</i>
<i>Annexure IV</i>	<i>Operational inputs of mechanised trawl harvesting systems</i> -----	<i>47</i>

Abbreviations

Ø	:	Diameter
\$:	Dollar
%	:	Percentage
ADP- fossil	:	Abiotic depletion potential (fossil)
AP	:	Acidification potential
CF	:	Carbon footprint
cm	:	centimetre
CML	:	Centre of Environmental Science, University of Leiden, The Netherlands
CO ₂	:	Carbon dioxide
CPUE	:	Catch Per Unit Effort
Cr	:	Crore
DCB	:	1,4-Dichlorbenzol
EEZ	:	Exclusive Economic Zone
EP	:	Eutrophication potential
Equiv.	:	Equivalent
FAO	:	Food and Agriculture Organization of the United Nations
FRP	:	Fiberglass reinforced plastic
g	:	Gram
GaBi	:	Ganzheitlichen Bilanzierung (German for holistic balancing)
GER	:	Gross Energy Requirement
GHG	:	Greenhouse gas
GJ	:	Giga joule
GPS	:	Global positioning system
GRT	:	Gross register tonnage

GWP	:	Global warming potential
h	:	Hour
HDPE	:	High density polyethylene
hp	:	Horsepower
HR	:	Head rope
IEA	:	International Energy Agency
IPCC	:	Intergovernmental Panel on Climate Change
ISO	:	International Organization for Standardization
IUU	:	Illegal, Unreported, and Unregulated
kg	:	Kilogram
kn	:	Knot (1.852 km per hour)
kWh	:	Kilowatt hour
L _{OA}	:	Length Overall
LCA	:	Life cycle assessment
LCI	:	Life cycle inventory
LCIA	:	Life cycle impact assessment
Lub oil	:	Lubricating oil
MAETP	:	Marine aquatic ecotoxicity potential
m	:	Metre
MJ	:	Mega Joule
mm	:	Millimetre
NMVOC	:	Non-methane volatile organic compounds
O ₃	:	Ozone
ODP	:	Ozone layer depletion potential
PA	:	Polyamide
PE	:	Polyethylene
POCP	:	Photochemical ozone creation potential

PP	:	Polypropylene
ppm	:	Parts per million
PUF	:	polyurethane foam
R11	:	Trichlorofluoromethane
Rs.	:	Rupees
SO ₂	:	Sulphur dioxide
SWR	:	Steel wire rope
t	:	Tonne
VACS	:	Vessel analysis computing system
VHF	:	Very high frequency
WMO	:	World Meteorological Organisation

1.1 World fisheries

Fishing is a major source of food for the humanity and provides employment and economic benefits to large sections of the society. Fish is a vital source of quality protein cheaper in cost when compared to other animal proteins and fisheries forms an important component of the economic activities, generating income, employment, livelihood and nutritional security for a large number of people. In 2010, fish accounted for 16.7% of the global population's intake of animal protein and 6.5% of all protein consumed. Moreover, fish provided more than 2.9 billion people with almost 20% of their intake of animal protein, and 4.3 billion people with about 15% of animal protein. Fish and fishery products are among the most traded food commodities worldwide, with trade volumes and values reaching new highs and expected to continue to rise (FAO, 2012a). The value of fish internationally traded has been estimated at US\$102 billion during 2010 (FAO, 2012a). Capture fisheries and aquaculture supplied the world with about 158 million tonnes of fish in 2012, of which about 136.2 million tonnes (86%) were utilized as food for people (FAO, 2014). World per capita food fish supply increased from an average of 9.9 kg (live weight equivalent) in the 1960s to 19.2 kg in 2012 (FAO, 2014). Out of the total world fisheries, marine capture fisheries accounted for 79.7 million tonnes in 2012 (FAO, 2014).

In 2010, employment from fisheries and aquaculture is estimated to support the livelihoods of 660–820 million people worldwide (FAO, 2012a;

Suuronen *et al.*, 2012). Marine capture fisheries are the most diverse of the major global food producing sectors, both in terms of the range of species harvested (Froese & Pauly, 2000) and harvesting technologies used (Brandt, 2005). The total number of fishing vessels in the world in 2010 is estimated at about 4.36 million. Of these, 3.23 million vessels (74%) operate in marine waters and the remaining 1.13 million vessels in inland waters (FAO, 2012a).

One of the main objectives of the concept of responsible fishing is to maximize economic returns to the fisherman without affecting the long-term sustainability of the fishery resources and with minimum impact on the ecosystem. Global capture fishery production has been plateauing and has more or less stabilized at around 80 million tonnes (Fig. 1.1). Trend in the state of marine fish stocks shows that proportion of overexploited and fully exploited marine fish stocks are increasing with simultaneous decrease in fish stocks that are not fully exploited (FAO, 2014) (Fig. 1.2). In 2011, about 61.3% of the world fish stocks monitored by FAO were fully exploited, 28.8% over-exploited, and only 9.9% were left at levels not reaching full exploitation. Most fishery resources are considered to be exploited at levels close to or beyond their sustainable limits. Analysis of data from five ocean basins revealed 90% decline in numbers of large predatory fishes such as tuna, blue marlins and swordfish, since the advent of industrialized fishing (Myers & Worm, 2003; Worm *et al.*, 2006, 2009). Fishing down effect is pervasive in world fisheries, including Indian fisheries (Pauly *et al.*, 2003; Pauly & Maclean, 2003; Bhathal, 2005; Vivekanandan *et al.*, 2005; Worm *et al.*, 2006; Bhathal & Pauly, 2008).

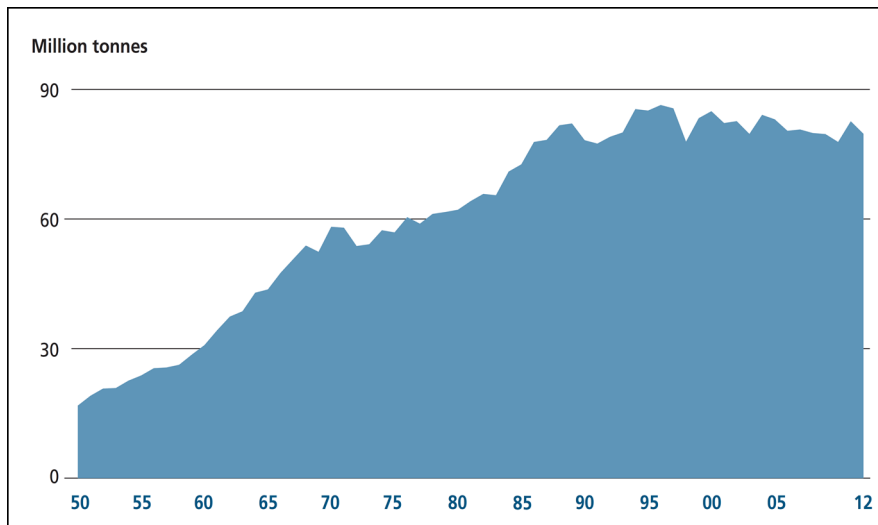

Fig. 1.1 Trend in global marine capture fishery production (Source: FAO, 2014)

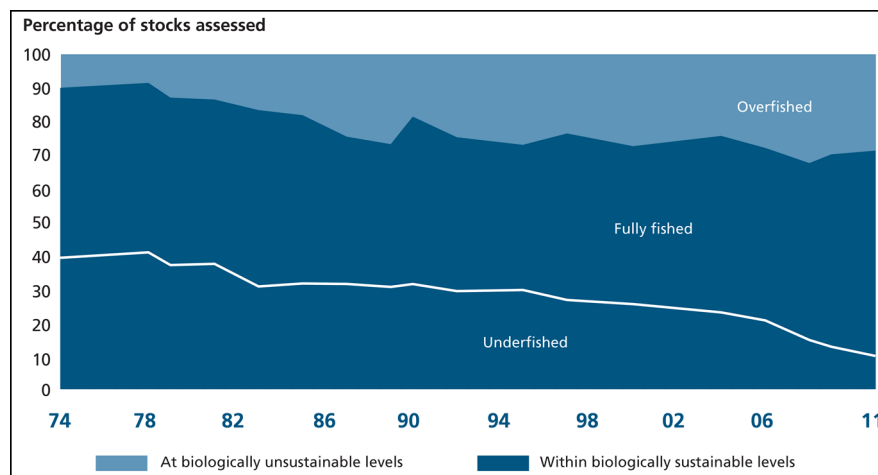

Fig. 1.2 Global trends in the state of marine fish stocks during 1974-2011 (Source: FAO, 2014)

1.2 Indian fisheries

India has a coastline of 8118 km and 0.5 million sq. km continental shelf endowed with 2.02 million sq. km of Exclusive Economic Zone (EEZ) (ICAR, 2011). It has a catchable annual fisheries potential yield of 4.42 million t occupying a significant role in world marine fish production, of

which the pelagic resources account for 2.128 million t; demersal resources for 2.083 million t and oceanic resources for 0.280 million t (GOI, 2011). Fishing contributes significantly to foreign exchange earnings of India and many other developing countries. Marine fish production of India which was only 0.58 million tonnes in 1950, increased to 3.94 million tonnes in 2012 (CMFRI, 1969; CMFRI, 2013a). Indian fisheries is increasingly contributing to the nutritional security of the country, with the present production of fish and shellfish from marine capture fisheries being around 3.59 million tonnes (CMFRI, 2015). The present catch of 3.59 million tonnes forms 81.40% of the estimated marine fishery potential and is largely derived from the intensively fished coastal zone. Of these, contributions from mechanised, motorised and non-motorised sectors were 75%, 23% and 2% respectively. The west coast of India contributed significantly to the total marine fish landings which accounted for 64% of the landings. The south-west region comprising Kerala, Karnataka and Goa was the top contributor with 33% of the marine landings (CMFRI, 2015). Hameed & Boopendranath (2000) and Sreekrishna & Shenoy (2001), had discussed fishing craft and gear technology. The mechanised marine fishing systems of India has been discussed in detail by Edwin *et al.* (2014b).

The number of fishermen in India has been estimated at around 4 million, of which more than 90% are from traditional fishermen families (CMFRI, 2012). Almost 35% of the Indian population are fish eaters and per capita consumption is 9.8 kg whereas the recommended intake is 13 kg (Ministry of Statistics and Programme Implementation, 2011). The fisheries sector contributed 0.78% to the total Gross Domestic Product (GDP) and 4.47% to agriculture GDP during 2011-12 (DADF, 2013).

Fish products form an important commodity in the export market. Marine products exports, crossed all previous records in quantity, rupee value and US \$ terms in 2014-15. The contribution to foreign exchange earnings by the fishery sector substantially increased from Rs. 46 crores in 1960 - 61 to Rs. 33,442 crores (US\$ 5511.12 million) in 2014-15 (MPEDA, 2015). Seafood exports from India, during 2012-13, has been 10,51,243 tonnes (MPEDA, 2015). Major exported seafood items from India in terms of value have been frozen shrimp, followed by frozen fish, frozen squid, frozen cuttlefish, dried items, chilled items, live items and others. India exports about 786 types of marine products to different countries out of which the main export markets include South-east Asia, European Union, USA, Japan, China and Middle East nations (MPEDA, 2012; 2013).

The increase in fish production over the years has been the result of increased fleet size and vessel capabilities, availability of large and more efficient gear systems, development in electronic, navigational and acoustic fish detection equipment, which increased the area of operation of the mechanised fishing fleet.

Mechanised fishing fleet

As per CMFRI marine census 1980, the total number of mechanised fishing vessels in 1980 were 9289 only (CMFRI, 1981). The number has increased to 58911 in 2005 and to 72559 in 2010 (CMFRI, 2006, 2012; DOF 2007). In the marine fisheries sector, there are 194,490 crafts of which 37% are mechanised, 37% motorised and 26% non-motorised (CMFRI, 2012). Actual excess capacity could be much higher, as the fishing power of the individual fishing units have significantly grown, during last decade, due to advances in technology and enhancement in horsepower and capacities of the

vessel (Boopendranath, 2009). With increasing fishing pressure in the coastal waters, fishermen operating in mechanised sector were forced to go to deeper waters in search for newer fishing grounds in order to maintain their catches (Watson & Pauly 2001; Pauly *et al.*, 2002; Pauly *et al.*, 2003). Marine fisheries have gone through significant changes since the 1950s and the changes in number and capacities have been more significant in the last decade. Excess capacity and increase in consumption of fuel by the mechanised vessels have been worsening over the period of time. During the past couple of decades the fishing fleet in the country underwent an explosive increase in terms of both number of vessels and their efficiency. Tremendous technological progress has taken place in vessel design and construction and operations of modern fishing vessels.

Fishing capacity in marine fisheries

Fig. 1.3 shows the increase in number of fishing vessels during 2010 when compared with the optimum fleet size recommended by GOI (2011).

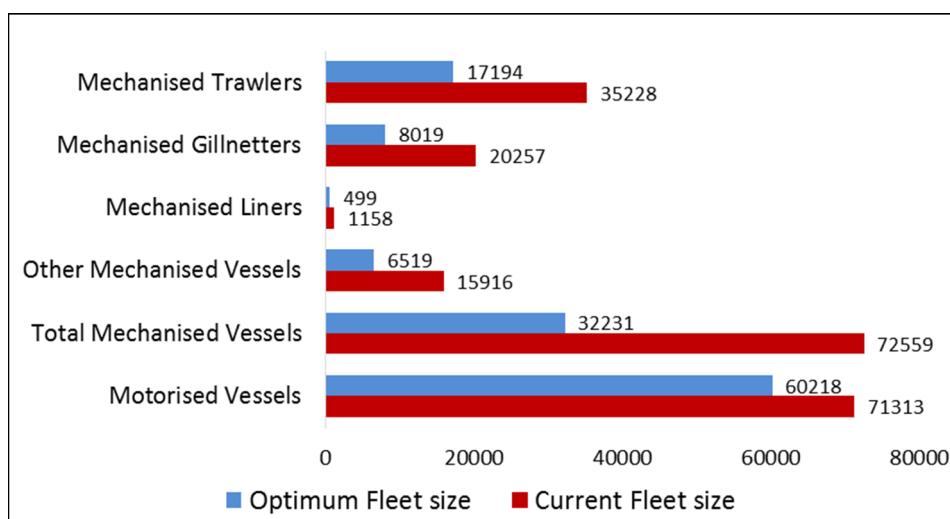

Fig. 1.3 Present fleet size and estimated optimum fleet size for marine fisheries of India

Source: Optimum fleet size - GOI (2011); Current fleet size - CMFRI (2012)

The implementation of the programme of vessel mechanisation in India was broadly divided into a base and four development phases (Silas, 1977). Introduction of small mechanised vessels, motorisation of country vessels, introduction of resource specific vessels and introduction of fishing fleet with state of the art equipment for fish detection and capture were the four development phases. The Indo-Norwegian Project first initiated the mechanisation programme in the country in 1957 (Rajasenan, 1987).

Most significant technological developments which supported the evolution of fish harvest technology have been (i) introduction of synthetic gear materials; (ii) developments in vessel technology and mechanisation of propulsion & gear; (iii) catch handling and onboard preservation; (iv) advances in electronic navigation and position fixing equipment; and (v) developments in acoustic fish detection and satellite based remote sensing techniques (Boopendranath, 2009).

1.3 Kerala fisheries

Marine fish landings in Kerala during 2014 is estimated at 5.76 lakh t (CMFRI, 2015). Pelagic finfishes constituted 68%, demersal fishes 15%, crustaceans 9% and molluscs 8% of the total landings during 2014. Among the commercially important resources landed, district wise, Ernakulam contributed the maximum (141090 t) in 2014. Among the mechanised sector, bulk of the landings were by trawlers, purse seiners and ring seiners. The first experimental shrimp trawling along Kerala was conducted in 1955, off Malabar coast using a 6.6 m L_{OA} , 10 hp open motor vessel. A Gulf of Mexico type flat trawl with a head rope of 9.6 m was used during the operation and consistently impressive catches of shrimp were recorded from the shallow coastal waters of depths 4-18 m (Kristjonsson, 1967). This finding together

with the increased demand for shrimps for the export market, gave a major fillip to the commencement of commercial shrimp trawling in Kerala and in other Indian maritime states. This was soon followed by various technological developments, with focus to expand the fisheries into deeper waters (Boopendranath, 2009). The Indo-Norwegian Project and Central Institute of Fisheries Technology were the two major organizations that catered to the development of mechanised fishing, especially trawling along the Indian coast. Vivekanandan (1993), Boopendranath (2000) discussed the structural changes that has taken place in coastal fisheries of Kerala and the growing energy inefficiency in the fisheries sector.

1.4 Energy consumption in fisheries

The Intergovernmental Panel on Climate Change (IPCC) has stated that anthropogenic emissions of greenhouse gases are contributing significantly and causing negative impacts on the Earth's climate. The Panel has warned that global mean temperatures are rising and patterns in precipitation and extreme weather events are becoming more frequent (United Nations, 2008). Concrete global action was first proposed in the Kyoto-protocol (United Nations, 1998), where the world industrial nations agreed on concrete figures of how much to reduce emissions of greenhouse gases (GHG). IPCC had launched several reports that not only showed that global warming is already taking place, but also showed that the consequences of human activity will continue for centuries (Houghton *et al.*, 1990; Houghton *et al.*, 1992; Houghton *et al.*, 1995; Houghton *et al.*, 2001). The upper safety limit for atmospheric CO₂ is 350 ppm. The levels of atmospheric CO₂ have stayed higher than 350 ppm since early 1988. According to latest data, concentration of atmospheric CO₂ during May 2013 is 400 ppm (Anon, 2013). Global warming impacts the marine fisheries, as fish stocks tend to migrate to cooler

waters (Warren, 2004; Loeng & Furevik, 2005; Lorentzen & Hannesson, 2005; Sullivan, 2006; Cheung *et al.*, 2013).

The recent Paris Agreement on 12 December 2015 puts the world's nations on a course that could fundamentally change the way energy is produced and consumed, gradually reducing reliance on fossil fuels in favour of cleaner forms of energy and calls on the world to collectively cut and then eliminate greenhouse gas pollution (C2ES, 2015). Healthy seas and services that they offer is the key to our future (Nellemann *et al.*, 2008). Most of the fishing techniques used today have their origin in a period when fisheries resources were abundant, energy costs were significantly lower than current levels, and when less attention was paid to operating efficiency and negative impacts of fishing on marine and atmospheric ecosystems (FAO, 2012a).

Modern fishing is one of the most energy intensive methods of food production (Tyedmers, 2004; Tyedmers, *et al.*, 2005; Boopendranath, 2009). Mechanised fishing is dependent on fossil fuels which are non-renewable and limited. According to the current levels of consumption, the fossil fuels may not last long, unless urgent conservation measures are taken. Combustion of fossil fuels and the release of greenhouse gases to the atmosphere cause environmental impact and contributes to climate changes and acidification.

The global fishing fleet burns almost 50 billion litres of fuel per year (average of 620 litres of oil per tonne of fish) pumping more than 130 million tonnes of CO₂ into the atmosphere which is an average of 1.7 tonnes of CO₂ per tonne of landed product. (Tyedmers *et al.*, 2005). The average estimated ratio of CO₂ emissions for capture fisheries is around 3 teragrams per million tonnes of fuel combustion (FAO, 2009). According to Tyedmers *et al.* (2005) the energy content of the fuel burned by global fisheries is 12.5 times greater than the edible

protein energy content of the resulting catch. World Bank and FAO (2009) reported that the global fishing fleet consumes approximately 41 million tonnes of fuel per annum at a cost of US\$ 22.5 billion, which generates approximately 130 million tonnes of CO₂. However, there is a paucity of detailed data on GHG emissions from fishing vessels (Buhaug *et al.*, 2009).

Fossil fuels used for vessel propulsion and gear handling in active fishing systems are known to be non-renewable and limited. Recently, increasing importance has been placed on adopting responsible fishing practices for minimizing waste by reducing the level of discards, optimize energy use and protect the environment from negative impacts (Boopendranath, 2000). Annual fuel consumption by the mechanised and motorised fishing fleet of India has been estimated at 1220 million litres which formed about 1% of the total fossil fuel consumption in India in 2000 (122 billion litres) releasing an estimated 3.17 million tonnes of CO₂ into the atmosphere at an average rate of 1.13 tonnes of CO₂ per tonne of live-weight of marine fish landed (Boopendranath, 2008). Vivekanandan *et al.* (2013) had estimated the diesel burning by the mechanised and motorised fishing vessels in India as 1378.8 million litres in 2010. These release about 3.13 million tonnes of CO₂ into the atmosphere at an average rate of 1.02 tonnes of CO₂ per tonne of live-weight of marine fish landed.

Introduction of powerful and highly efficient harvesting systems, progress in fish detection and gear monitoring systems and market driven expansion of fishing fleet since the second world war, brought about increasing pressure on the world fishery resources (Boopendranath, 2000) and increase in consumption of fuel per unit of fish landed (Tyedmers *et al.*, 2005; FAO, 2012a). The global concern about CO₂ emissions (Tyedmers *et al.*, 2005) and the recent increases in fuel price (Sumaila *et al.*, 2008; Abernethy *et al.*, 2010) are both incentives for the fishing sector to reduce fuel consumption, by developing fuel efficient fishing technologies and practices.

Fuel consumption rate varies widely according to gear type and fishing practice (Boopendranath, 2008, Thrane, 2004b; Tyedmers *et al.*, 2005; FAO, 2007; Schau *et al.*, 2009; Winther *et al.*, 2009). Operational techniques and the distances between fishing grounds and fishing ports, as well as vessel design and age will all affect the amount of fuel consumed. There are also substantial differences in fuel consumption between fisheries targeting groundfish or shellfish and those targeting pelagic fish or industrial fish (Schau *et al.*, 2009; Schau, 2012). Selection and deployment of energy efficient mix of harvesting technologies appropriate for target resources is one of the main options available for fuel conservation. Large variations in energy use exist among different fishing gears. Gulbrandsen (1986) reported that trawling consumes 0.8 kg of fuel while longlining and gillnetting consumes between 0.15 and 0.25 kg of fuel and purse seining requires 0.07 kg of fuel, to catch one kilogram of fish.

In trawling typically a substantial portion of the time is spent on towing the gear. During the tow, resistance of the vessel is insignificant compared to the resistance of the gear. The gear resistance therefore has a large effect up on overall fuel economy. Ward *et al.* (2005) studied trawls constructed using novel materials, which led to a reduction in drag of 6% and an increase in mouth opening by 10%. Parente *et al.* (2008) have improved bottom trawls by using larger meshes and by changing the taper of trawl panels, which generated fuel reduction up to 18%. Modification of existing gears, development of low drag gears and adoption of alternative fuel-efficient gears all represent means to improve fuel efficiency.

In view of the growing significance of energy use and its impacts on environment, energy inputs in marine fishing and post-harvest operations have been studied by several authors in recent years (Boopendranath, 2000; Tyedmers 2001; Thrane, 2004b; Sterling & Goldsworthy, 2007; Sumaila *et al.*,

2008; Winther *et al.*, 2009; Abernethy *et al.*, 2010; Driscoll & Tyedmers, 2010; Vázquez-Rowe *et al.*, 2011; Suuronen *et al.*, 2012; Tyedmers & Parker 2012).

Endal (1980) has given fuel consumption for different fishing methods as 0.6 -1.0 kg for bottom trawling, 0.2 - 0.3 kg for long lining, and 0.1 kg for coastal fishing, per kg of fish landed. Energy analysis of non-motorised, motorised and mechanised fish harvesting systems operating in Indian waters has been reported by Edwin and Hridayanathan (1997), Boopendranath (2000), Boopendranath and Hameed (2009; 2010), Edwin (2013) and Vivekanandan *et al.* (2013). Direct fuel energy inputs to fisheries typically account for 75 to 90% of the total energy inputs and the remaining 10 to 25% is comprised of direct and indirect energy inputs associated with vessel construction and maintenance, fishing gear and others (Wiviott & Mathews, 1975; Rochereau, 1976; Leach, 1976; Edwardson, 1976; Rawitscher 1978; Lorentzen, 1978; Allen 1981; Watanabe and Uchida, 1984; Watanabe & Okubo, 1989; Tyedmers, 2000). FAO (1981) discussed the relationship between energy and other inputs in fish harvesting. Grofit (1981) studied the fuel use in trawl industry and advocated various measures for making trawling more fuel efficient. Watanabe and Uchida (1984) gave an estimate of the direct and indirect energy inputs in the catch of fish for fish paste products, with respect to Alaska pollack harvest in North Pacific Ocean. The total amount of energy used by a fishing vessel will vary depending on the size and design of the vessel, weather conditions, type and size of fishing gears, location, skill and knowledge of the crew (Sala *et al.*, 2012). Madhu and Panda (2009) had studied the effect of tow duration and speed on the capture efficiency of bottom trawl.

The fuel consumption estimates per kg of fish for trawling from different fisheries are summarised in Table 1.1.

Table 1.1: Comparison of fuel consumption (kg fuel kg fish⁻¹) in different trawl fisheries

Type of fishing and location	Fuel consumption (kg fuel kg fish ⁻¹)	Reference
Traditional motorised mini-trawling (India)	0.41	Boopendranath (2000; 2008)
Small-scale mechanised bottom trawling (India)	0.38	Boopendranath (2000; 2008)
Large-scale mechanised aimed midwater trawling (India)	0.33	Boopendranath (2000; 2008)
Large-scale mechanised bottom trawling (India)	1.34	Boopendranath (2000; 2008)
Trawling for small pelagic fishes (North Atlantic)	0.08	Tyedmers (2001)
Trawling for pelagic fishes (Norway)	0.09	Schau <i>et al.</i> (2009)
Trawling for groundfish (North Atlantic)	0.44	Tyedmers (2001)
Trawling for groundfish (Baltic Sea)	1.5	Ziegler <i>et al.</i> (2003)
Trawling for groundfish (Denmark)	1.4	Bak (1994)
Trawling for codfish (Denmark)	0.4	Thrane (2004b)
Bottom trawling for flatfish (Denmark)	0.84	Thrane (2004b)
Trawling for groundfish (Iceland)	0.65	Ziegler and Hansson (2003)
Trawling for groundfish (Norway)	0.28	Schau <i>et al.</i> (2009)
Trawling for shrimp (North Atlantic)	0.76	Tyedmers (2001)
Trawling for shrimp (Norway)	1.04	Schau <i>et al.</i> (2009)
Trawling for Norwegian lobster (North Atlantic)	0.85	Tyedmers (2001)
Trawling for cephalopods (Mauritius)	1.74	Vázquez-Rowe <i>et al.</i> (2012a)
Trawling for cod (North Atlantic, North-east Atlantic, Baltic Sea, Denmark, Norway, Iceland)	0.67	Tyedmers (2001); Eyjólfsdóttir <i>et al.</i> (2003); Ziegler <i>et al.</i> (2003); Thrane (2004a); Ellingsen and Aanonsen (2006); Guttormsdóttir (2009)
Trawling for groundfish (Denmark, North-west Spain)	1.52	Thrane (2006) Iribarren <i>et al.</i> (2010a)
Trawling for hake (North-west Spain)	2.10	Vázquez-Rowe <i>et al.</i> (2011)
Trawling for lobsters and crabs (North Atlantic, Denmark, Norway)	3.85	Tyedmers (2001); Thrane (2004a); Ziegler and Valentinsson (2008)
Trawling for mackerel (Denmark, North-west Spain)	0.30	Thrane (2004a); Iribarren <i>et al.</i> (2010a); Vázquez-Rowe <i>et al.</i> (2010b)
Artisanal trawling for shrimps (Senegal)	0.52	Emanuelsson <i>et al.</i> (2008)
Trawling shrimps (North Atlantic, Denmark, Senegal)	1.06	Tyedmers (2001); Thrane (2004a); Emanuelsson <i>et al.</i> (2008)
Trawling small pelagic fish (Denmark, Northwest Atlantic)	0.10	Thrane (2004a); Driscoll and Tyedmers (2010)

Most of the available literature on energy and fisheries deals only with the operational aspects of consumption. Gross Energy Requirements (GERs) for Indian fish harvesting systems during the year 2000 has been studied by Boopendranath, 2000; Boopendranath and Hameed, 2009, 2010; Boopendranath and Hameed, 2013. As per their study mechanised trawling is the most energy intensive fish harvesting system with GER t fish⁻¹ values ranging from 31.40 to 36.97 GJ, indicating an overall consumption of 0.73-0.86 t of fuel for every tonne of fish produced. Energy intensity of wooden hulled trawlers, steel hulled trawlers, purse seiners and gill netting cum lining were calculated as 7.69, 8.91, 1.34 and 5.99 respectively in Indian fisheries (Boopendranath, 2000).

Energy use in trawling

Energy intensity can vary considerably depending on the fishing gear used. In general, trawling tends to be more energy intensive than seining, purse seining or more passive techniques such as gillnetting, and trapping (Wiviott & Mathews, 1975; Leach, 1976; Edwardson, 1976; Lorentzen, 1978; Rawitscher, 1978; Nomura, 1980; Hopper, 1982; Watanabe & Okubo, 1989, Tyedmers, 2001). An exception to this relative energy intensity pattern occurs with respect to longlining, a passive fish harvesting technology which typically requires relatively large energy inputs relative to the tonnes of fish landed, particularly when used to catch high value pelagic species such as tuna, and billfish (Rawitscher, 1978; Nomura, 1980; Watanabe & Okubo, 1989). In many instances, energy intensity has been found to increase with vessel size within a given fishery (Wiviott & Mathews, 1975; Rochereau, 1976; Edwardson, 1976, Lorentzen, 1978; Watanabe & Okubo, 1989). The energy intensity of a fishery can change dramatically over time as the abundance of fisheries resources change, fleets expand, the average size of vessels increase, vessels travel further to fish, and become more technologically advanced. For example, Brown and Lugo (1981) estimated that

between 1967 and 1975, while the fuel consumed by the U.S. fishing fleet (excluding vessels under 5 GRT) increased from 150 to 319 million gal/year, the catch did not increase accordingly. As a result, the fossil energy input to edible protein energy output ratio for the U.S. fleet increased from 8:1 to almost 14:1 over the same period. Similarly, Mitchell and Cleveland (1993) found that between 1968 and 1988, the fuel energy input to edible protein output ratio of the New Bedford, Massachusetts fleet rose from 6:1 to over 36:1.

Energy inputs in GJ/tonne of fish landed for trawl fishing and different fishery groups are summarised in Table 1.2.

Table 1.2: Comparison of energy intensity in commercial fisheries

Fishery / location	Energy intensity (GJ/t)	Inputs for energy analysis	Source
Trawling for small pelagics (N. Atlantic)	3.5	Fuel	Tyedmers (2001)
Trawling for pollock (Japan)	7.5	Fuel	Nomura (1980)
Trawling for shrimp (N. Atlantic)	33	Fuel	Tyedmers (2001)
Trawling for Norway lobster (N. Atlantic)	37	Fuel	Tyedmers (2001)
Trawling for groundfish (N. Atlantic)	19	Fuel	Tyedmers (2001)
Trawling for groundfish (Japan)	38	Fuel	Nomura (1980)
Trawling for shrimp (U.S.)	358	Fuel	Leach (1976)
Trawling for shrimp (Australia)	38	Fuel, vessels	Leach (1976)
Trawling for perch (Maine, U.S.)	6 to 8	Fuel, gear, vessels	Rawitscher (1978)
Trawling for cod (Massachusetts, U.S.)	18 to 20	Fuel, gear, vessels	Rawitscher (1978)
Trawling for flounder (Rhode Island, U.S.)	20 to 22	Fuel, gear, vessels	Rawitscher (1978)
Trawling for haddock (Massachusetts, U.S.)	34 to 42	Fuel, gear, vessels	Rawitscher (1978)
Trawling for shrimp (Texas, U.S.)	270 to 312	Fuel, gear, vessels	Rawitscher (1978)

The dramatic escalation in oil prices during the seventies brought the need for fuel conservation to a sharp focus. Since the turn of the century, the real global price of crude oil has increased by about 500% (Yergin, 2011). Spiralling oil prices may severely affect the economic viability of fishing as a

means of food production (Boopendranath, 1996). The price of diesel had increased significantly from Rs. 3.5 per litre in 1989 to Rs. 56.3 in 2015 (Fig. 1.4) (IOCL, 2015; Reuters, 2015)

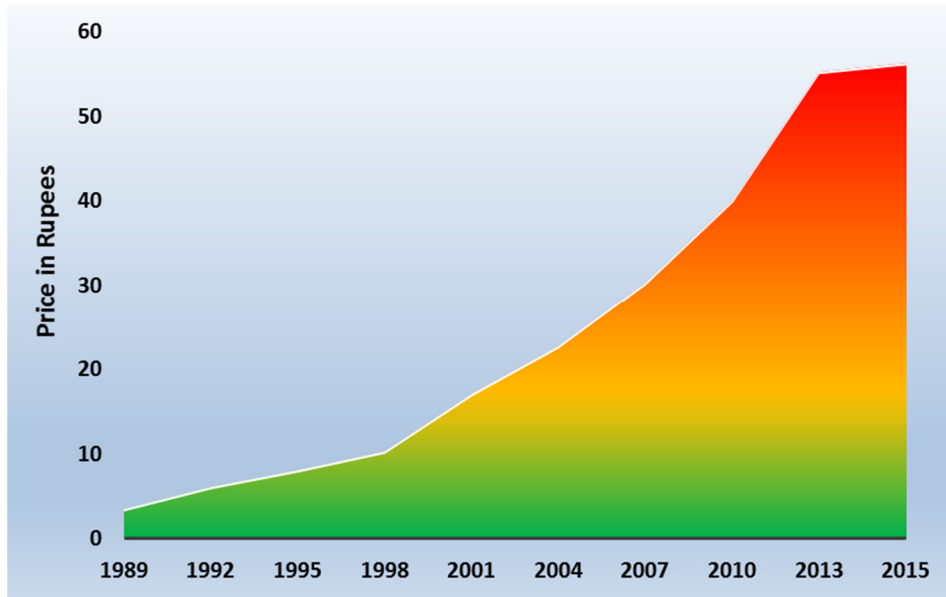

Fig. 1.4 Increase of price in diesel in the last 25 years (Source: IOCL, 2015; Reuters, 2015)

Fossil fuels currently provide 85% of the world's energy needs (BACAS, 2006; Botkin & Keller, 2007). Current mechanised fishing may not be sustainable due to its over dependence on non-renewable fossil fuel energy like diesel. Spurred initially by the oil price shocks of the 1970s, analyses have been undertaken on a wide range of fisheries, either to evaluate their energy efficiency (Wiviott & Mathews, 1975; Leach, 1976; Rawitscher & Mayer 1977; Ágústsson *et al.*, 1978; Rawitscher, 1978; Lorentzen, 1978; Ragnarsson, 1979, 1985; Nomura, 1980; Allen, 1981; Brown & Lugo, 1981; Veal *et al.*, 1982; Hopper, 1982; Watanabe & Uchida 1984; Ishikawa *et al.*, 1987; Sato *et al.*, 1989; Watanabe & Okubo, 1989; Mitchell & Cleveland, 1993; Pimentel *et al.*, 1996; Boopendranth, 2000, 2009; Tyedmers, 2001; Tyedmers, 2004;

Alpanda & Peralta-Alva, 2010; Marlen & Salz, 2010; Balash & Sterling, 2012) or to assess their economic vulnerability to potential increases in oil prices (Scott, 1981; Samples, 1983; George *et al.*, 1993; Senthilathiban *et al.*, 1997; Salz & Framian, 2006; Bjørshol, 2007). These studies indicate that direct fuel inputs typically account for 75 - 90% of total energy inputs to fishing activities (Rawitscher, 1978; Watanabe & Uchida, 1984; Tyedmers, 2000). Rising fuel costs has promoted research and development on various energy saving technologies (Curtis *et al.*, 2006; Winther *et al.*, 2009; Abernethy *et al.*, 2010; Heredia-Quevedo, 2010; E-Fishing, 2010). Increasing fuel prices often results in governments establishing fuel-subsidies to support the viability of fishing operations (Sumaila *et al.*, 2008, 2010; World Bank & FAO, 2009) but such subsidies often work against the development of energy efficient fishing operations.

1.5 Impact of energy use in environment

Effort is the function of number of fishing vessels and the capacity of individual fishing vessels constituting the fleet. Increased greenhouse gases caused by increased fishing effort will contribute to climate change (Fig. 1.5). The climate change in the tropical seas may affect the productivity and may have negative biological effects on species and ecosystems (Cheung *et al.*, 2013). This may ultimately lead to the decline of fish stocks and reduced CPUE. The reduced CPUE may again force the fishermen to increase fishing effort which could form a vicious cycle (Tan & Culaba, 2009, Ravi *et al.*, 2013). Distant water fishing is extremely energy intensive consuming 15 to 20 times more energy than it produces (Endal, 1989a).

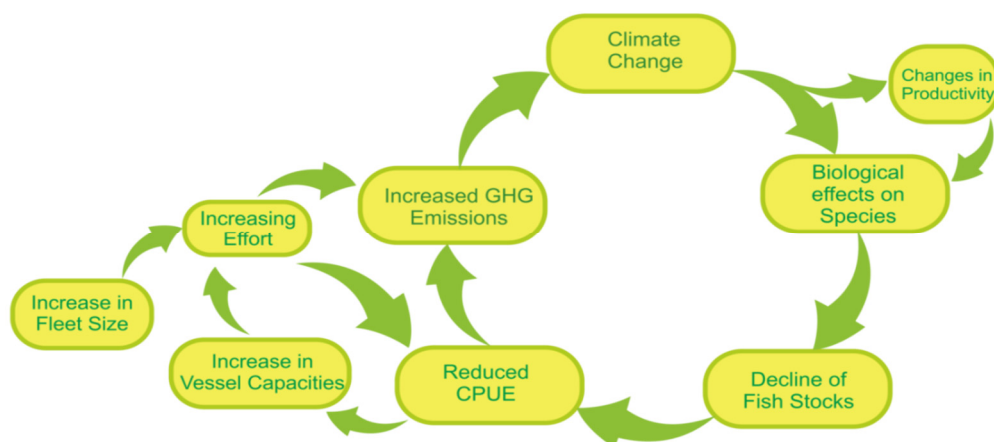

Fig. 1.5 Vicious cycle of increasing effort, decreasing landings and increasing GHG emissions, in fisheries (Source: Ravi *et al.*, 2013)

UNEP (United Nations Environmental Program) released a report named *In Dead Water* where it is stated that climate change is emerging as the latest threat to the world's reduced fish stocks (Nellemann *et al.*, 2008). Climate change threatens the sustainability of fisheries and is likely to affect biological processes and biodiversity at all regions of the planet at both small and large scales (Kaiser *et al.*, 2005). Studies have shown that ranges of individual fisheries are shifting in response to ocean warming (McCay *et al.*, 2011; Cheung *et al.*, 2012; Pinsky & Fogarty, 2012) and such changes in distribution have been occurring globally for several decades (Cheung *et al.*, 2013).

1.6 Life cycle assessment and carbon footprint studies in fisheries

Most of the environmental concerns with respect to commercial fishing mainly focus on direct impacts to targeted species (Pauly *et al.*, 2002; Christensen *et al.*, 2003; Myers & Worm, 2003), bycatch and discards (Alverson *et al.*, 1994; Glass, 2000), alterations to benthic communities (Johnson, 2002; Chuenpagdee *et al.*, 2003), and modifications to trophic dynamics (Jackson *et al.*, 2001). These concerns do not cover all aspects

related to the environmental impacts of fishing activities (Iribarren *et al.*, 2010a and Iribarren *et al.*, 2011). In this background, LCA has arisen as a suitable methodology to undertake the environmental assessment of products through a life-cycle approach (Pelletier *et al.*, 2007).

LCA is recognized worldwide as a useful tool for assessing environmental aspects and potential impacts associated with products or processes (ISO 2006a, 2006b), and can be a suitable methodology for the analysis of the environmental performance of fisheries (Pelletier *et al.*, 2007; Vázquez-Rowe *et al.*, 2010a; 2010c). LCA is a compilation of the inputs and outputs and evaluation of potential environmental impacts of a product throughout its lifecycle (ISO 2006a, 2006b; Pelletier *et al.*, 2007). LCAs are used to identify environmentally preferred products or methods and to provide insight into the main causes of the environmental impact of a product or process and for determining design priorities. LCA can be used as a support tool for policy and decision-making or as a methodology for benchmarking in terms of eco-efficiency (Vázquez-Rowe *et al.*, 2010a). In India, till now no study has taken place related to LCA for trawl fishing wherein impact categories such as Global warming potential, Abiotic depletion potential (fossil), Acidification potential, Eutrophication potential, Marine aquatic ecotoxicity potential, Ozone layer depletion potential and Photochemical ozone creation potential are considered. The Carbon Footprint (CF) is just one output from the life cycle assessment. The Carbon Footprint is a measure of the amount of CO₂ and other GHG emissions that is directly and indirectly caused by an activity or is accumulated over the life stages of a product. This is usually expressed in kilograms of CO₂ equivalents (Gerber *et al.*, 2010). CO₂ equivalents represent the equivalent concentration of CO₂ that would cause the same warming effect on the atmosphere.

LCA allows for comprehensive evaluations to be made on the environmental impacts related to products over their whole life cycle, encompassing infrastructure, energy provision, extraction of raw materials, manufacturing (cradle-to-gate), distribution, use and final disposal (cradle-to-grave) (ISO, 2006b). LCA is thus a tool aimed to, among other purposes, identify opportunities for improving environmental performance and inform decision makers on the environmental performance of products, product systems and even their alternatives (ISO, 2006a).

Energy analysis are relevant in relation to fisheries due to the accepted importance of fuel consumption in fleet operations (Tyedmers, 2001) and associated environmental impacts (Thrane, 2004a; Schau *et al.*, 2009; Driscoll & Tyedmers, 2010). Carbon footprint is often considered as a sub-set of LCA (EC/JRC, 2007) and is closely associated to fisheries LCA due to the strong impact of fuel consumption (Avadi & Freon, 2013).

LCA was first introduced in the late sixties in the United States and was first used to compare resource consumption and environmental impact associated with containers of beverages (European Environment Agency, 1997). In 1992, at the UN Earth Summit, LCA methodologies were announced to be the most promising tool for environmental management tasks (European Environment Agency, 1997). Studies by Thrane (2006) points out that if all flatfish in Denmark is caught by Danish seine nets or gillnets it would theoretically be possible to save 30 million litres of fuel per year within the Danish fishery or 15% of their total fuel consumption in a year. According to Eyjólfsson *et al.* (2003), LCA can be used for indicating hot spots within

production chain. By applying LCA on Icelandic cod product, Guttormsdóttir (2009) found that bottom trawled cod causes higher environmental impacts when compared with cod caught by long lines.

Pioneering studies on LCA and CF applied to fisheries include Eyjólfsdóttir *et al.* (2003), Ziegler *et al.* (2003) and Hospido and Tyedmers (2005). A range of seafood products have been investigated with LCA which includes cod (Eyjólfsdóttir *et al.*, 2003; Ziegler, *et al.*, 2003; Ellingsen & Aanonsen, 2006; Vold & Svanes, 2009; Svanes *et al.*, 2011), shrimp (Mungkung, 2005; Mungkung, *et al.*, 2006; Ziegler *et al.*, 2009), tuna (Hospido & Tyedmers, 2005; Hospido *et al.*, 2006), various Finnish fish products (Silvenius & Grönroos, 2004), various Danish fish products (Thrane, 2004a, 2006), salmon (Ellingsen & Aanonsen, 2006; Watanabe & Tahara, 2008; Pelletier *et al.*, 2009), Norway lobster (Ziegler & Valentinsson, 2008), Pacific saury (Ishida *et al.*, 2008), various Norwegian fish products (Schau *et al.*, 2009), horse mackerel (Vázquez-Rowe *et al.*, 2010b), frozen common octopus (Vázquez-Rowe *et al.*, 2012a) and products derived from Antarctic krill (Parker & Tyedmers, 2012). A series of LCA-Food conferences have been held in Brussels (Ceuterick, 1998), Gothenburg (SIK, 2001; 2007), Bygholm (Halberg, 2004), Zurich (Nemecek, 2008) and Bari (Notarnicola *et al.*, 2010). Ghosh *et al.* (2014) has studied carbon footprint of marine fisheries of Visakhapatnam. LCA and related major studies in world fisheries including the targeted species, fishing methods and fishing region are given in Table 1.3.

Table 1.3: LCA and related studies in world fisheries

Targeted species	Fishing method	Fishing region	Authors
Codfish, small pelagic fish, tuna, shrimps & prawns, lobster & crab	Trawling, purse seining, trapping	Northeast Atlantic	Tyedmers (2001)
Cod	Trawling	Northeast Atlantic	Eyjólfsdóttir <i>et al.</i> (2003)
Cod	Trawling, gillnetting	Northeast Atlantic	Ziegler <i>et al.</i> (2003)
Cod, Norway lobster, Northern prawn, shrimp, herring, mackerel, Industrial fish	Trawling, purse seining	Northeast Atlantic	Thrane (2004a)
Skipjack, yellowfin tuna	Purse seining	Atlantic, Pacific, Indian oceans	Hospido and Tyedmers (2005)
Cod	Trawling, purse seining	Northeast Atlantic	Ellingsen and Aanondsen (2006)
Flatfish	Trawling	Northeast Atlantic	Thrane (2006)
Southern pink shrimp	Trawling	Eastern Central Atlantic	Emanuelsson <i>et al.</i> (2008)
Norway lobster	Creeling, trawling	Northeast Atlantic	Ziegler and Valentinsson (2008)
Cod	Trawling, long lining	Northeast Atlantic	Guttormsdóttir (2009)
Atlantic herring	Trawling, purse seining	Northwest Atlantic	Driscoll and Tyedmers (2010)
European hake, Atlantic horse mackerel, European pilchard, Anglerfish, Tuna	Trawling, long lining purse seining	Atlantic, Pacific, Indian oceans	Iribarren <i>et al.</i> (2010a)
European hake, Atlantic horse mackerel, Atlantic mackerel, blue whiting	Trawling	Northeast Atlantic	Vázquez-Rowe <i>et al.</i> (2010a)
Octopus	Trawling	Eastern Central Atlantic	Vázquez-Rowe <i>et al.</i> (2012a)
Atlantic mackerel	Purse seining	Northeast Atlantic	Ramos <i>et al.</i> (2011)
Cod	Long lining	Northeast Atlantic	Svanes <i>et al.</i> (2011)
European hake	Trawling, long Lining	Northeast Atlantic	Vázquez-Rowe <i>et al.</i> (2011)
Atlantic horse mackerel	Trawling, purse Seining	Northeast Atlantic	Vázquez-Rowe <i>et al.</i> (2010b)
Anchoveta	Purse Seining	Southeast Pacific	Fréon <i>et al.</i> (2014)
Marine fish	Mechanised and motorised fishing	Visakhapatnam, east coast of India	Ghosh <i>et al.</i> (2014)

In recent times, significant changes have taken place in capacities of the fishing craft, installed engine horse power, fish handling equipment and fishing gear. The increasing oil price, growing environmental consciousness and the change in availability of fish catch necessitates the reduction in energy use and hence there is a need for re-estimation of energy requirement of fishing systems by application of modern approaches like Life Cycle Assessment and Carbon Footprint.

The present investigations were done as there is no information on the life cycle assessment of fish production by trawlers being operated in Kerala fisheries. Information on fishery based life cycle assessment and carbon footprint estimation is very scarce and scattered in Indian fisheries and these aspects form a part of the present study. The results of this study will help policy makers in formulating regulations regarding the fleet size, engine horse power etc. for judicious management of marine fisheries.

1.7 Energy conservation in fisheries

Energy conservation is one of the important challenges facing the fishing industry today, apart from issues of resource conservation, protection of biodiversity and environmental safety (Boopendranath, 2000). Section 8.6 under Article 8: Fishing operations incorporated in the Code of Conduct for Responsible Fisheries (FAO, 1995) directly deals with Energy Optimization. Sub-section 8.6.1 prescribes that the States should promote the development of appropriate standards and guidelines which leads to the more efficient use of energy in harvest and post-harvest activities within the fisheries sector. Sub-section 8.6.2 prescribes that States should promote the development and transfer of technology in relation to energy optimization within the fisheries sector and, in particular, encourage owners and managers of fishing vessels to fit energy optimization devices to their vessels. Many nations are pursuing

large scale programmes in energy conservation, prompted by the economic and environmental imperatives.

Several papers connected to energy optimization in fishing, were presented and discussed in the 1988 World Symposium on Fishing and Fishing Vessel Design (Anon, 1989a) and elsewhere (Magnusson, 1989; Goudey & Venugopal, 1989; Enerhaug, 1989; Fridman & Lissovoy, 1989; McIlwaine *et al.*, 1989; Boopendranath, 2009).

International Fisheries Energy Optimization Working Group Meeting, University of British Columbia, Canada, considered how the existing harvesting techniques, vessel designs, resource management methods, energy policies and operational practices could best optimize use of energy (Anon, 1989b; Buxton & Robertson, 1989). The advantages of computerised vessel design, engine and gear performance monitoring systems in fuel conservation have been discussed by Burchett (1989) and Tait (1989a, 1989b). Fridman (1989) and Sevastanov (1989) enumerated the problems of energy optimization in fisheries, related to fishing techniques and ship building and engineering, in the erstwhile USSR. The need for making fishing crafts more energy efficient has been emphasised by Bay of Bengal Programme (Anon, 1984). Veenstra (1986) studied the application of energy saving concepts in Dutch fishing vessel design and operation. Mohanrajan (1987) discussed various energy alternatives available for fisheries sector.

Developments in midwater trawl design aimed at drag reduction and energy saving have been described by Kwidzinski (1989) and Marlen (1989b). Significance of hull form in efficient operation of fishing vessels has been discussed by Frostad (1989). Energy consumption pattern in coastal fisheries have been studied by Ben-Yami (1989); Hameed and Hridayanathan (1989). Energy saving in fishing vessels by introducing bulbous bow and improvements in

propulsion systems have been described by Calisal and McGreer (1989), McIlwaine (1989) and Kohane & Ben-Yami (1989). Endal (1989b) reviewed the policies, challenge and opportunities in energy optimization in fisheries. A study on the attitudes and knowledge on energy conservation among marine fishermen of Kerala was conducted by Sasikumar *et al.* (1992). Hameed and Kumar (1993) discussed the problems related to energy optimization in the fisheries sector. John (1996) and John *et al.* (1998) studied some aspects of fuel optimization in trawling operations along the Kerala coast and worked out the average yield of fish per litre of diesel consumed by trawlers. A study on the economics of energy in marine fisheries of Kerala was conducted by Mathew *et al.* (1992).

Seafish *et al.* (1993) studied fuel saving possibilities by improving design and rigging of otter boards. Fuel saving concepts in trawl design such as rope trawl and large mesh trawl have been studied by Marlen (1989a&b), Rao and Narayanappa (1994), Rao *et al.* (1994) and Kunjipalu *et al.* (1989, 1998). Methods of improving fuel efficiency were discussed by Dickson (1989), Gardner (1989) and Billington (1989). National Workshop on Low Energy Fishing, 8-9 August 1991, at Cochin, India, discussed several issues pertaining to low energy fishing gear and practices (Anon, 1993). Ben-Yami (1993) analysed the significance of low energy fishing in the context of present day energy crisis. Low energy fishing techniques used in Indian fisheries and various related issues were discussed by Kurup *et al.* (1993) and Gallene (1993); and low energy fishing vessels were discussed by Sheshappa (1993), George (1993), Pillai and Namboodiri (1993) and Choudhury (1993). ADB-ICLARM Workshop on Appropriate Technology for Alternative Energy Sources in Fisheries, Manila (Philippines) addressed the issue of fuel conservation in fish harvesting (May *et al.* 1981). The Workshop advocated a shift away from the emphasis on large and powerful fishing boats towards smaller boats which are

more fuel efficient; the development and use of passive fishing gears; development of improved and fuel efficient fishing methods and the use of sail power, wherever feasible. Bardach (1982) enumerated the energy resources of importance in the fishing industry. Fyson (1982) and Lee & Son (1982) advocated the use of sails in fishing vessels as a means of reducing fuel consumption. Gifford (1982) and Jiang (1982) discussed the development of low energy fishing vessels. Pinhorn (1986) has developed vessel analysis computing system (VACS) under the Ener Sea Programme, for reducing fuel expenditure of the Newfoundland inshore fishing fleet. Gulbrandsen (1986) after evaluating fuel saving opportunities, recommended a set of fuel saving measures appropriate for small fishing boats. Fishing Vessel Energy Efficiency Meeting organised by International Energy Agency (IEA), in Vancouver, British Columbia, Canada, focused on specific issues such as (i) the need for an energy consumption database for each fishery sector in each of the member countries, (ii) the need for an energy conservation inventory to reduce fuel consumption and harmful emissions from fishing fleet and (iii) the use of decision support systems for energy optimization (IEA, 1993). Aegisson and Endal (1993) studied the economic performance of the different fishing vessel categories, operating along the coast of Kerala and Karnataka states in India, as well as their relative dependence on the inputs of energy, labour and capital. This study was conducted under an Energy Conservation Programme which was jointly supported by the Governments of India and Norway. After an analysis of the technical and operational characteristics of mechanised vessels, the authors concluded that there is a massive potential for energy saving in the Indian fisheries and identified the need for technical and operational improvements to realise this potential. Ravindran (1998) discussed the trends in fishing craft development in India. Shibu (1999) has discussed the economic aspects of fuel

consumption pattern among purse seiners, trawlers and gillnetters, operating from Cochin. A study carried out by Seafish, investigated fuel efficiency in the UK fishing fleet and found that measures, such as reducing towing and steaming speeds, can provide fuel savings of up to 50%, whilst still working at 70% of the maximum capacity (Curtis *et al.*, 2006).

Approaches for energy conservation and minimization of GHG emissions from fishing operations have been reviewed by Wileman (1984), Gulbrandsen (1986), Aegisson and Endal (1993), Boopendranath (1996; 2009), Wilson (1999), Berg (2007), Sterling and Goldsworthy (2007), Sterling and Kim (2007), Espadafor *et al.* (2009), Remesan *et al.* (2009), Feng (2010), Rihan *et al.* (2010), Walsh (2010), TEFLES (2012) and Boopendranath and Hameed (2013) and include the appropriate adoption of fuel saving approaches and devices.

Adoption of Low Impact and Fuel Efficient (LIFE) capture techniques involving changes from current fishing methods or practices that use a high level of energy and cause high impacts on marine ecosystems, to methods with lower energy consumption and ecosystems impacts, offer opportunities for conserving fuel, preserving ecosystems and improving food security (Suuronen *et al.*, 2012). Fuel consumption and ecosystem impacts can be reduced through changes in operational techniques and gear design based on fish behaviour (Valdemarsen & Suuronen, 2003; Marlen, 2009; He and Winger, 2010; Rihan, 2010).

The foregoing review indicates that the fishing industry must take various measures to reduce fuel consumption and CO₂ emissions to protect environment and maintain economic viability of fishing operations.

1.8 Scope of the study

Kerala is a state in which large scale mechanised fishing activity is taking place. It has a coastline extending to 590 km, territorial sea area of 13,000 km², a continental shelf area of 39,139 km² and Exclusive Economic Zone of 1,47,740 km² and is endowed with rich marine resources (Edwin *et al.*, 2014a). Kerala ranked first in marine fish production of India forming nearly 21.3% (8.4 lakh tonnes) during 2012 (CMFRI, 2013a). The growing demand of fish resulted in intensification of fishing effort, extension of fishing grounds, increase in overall length and fish hold capacity and fishing effort in terms of enhanced fishing hours and multi-day fishing, in the mechanised sector. In Kerala, there are a total of 4,722 mechanised, 11,175 motorised and 5,884 non-motorised fishing vessels (CMFRI, 2012). The contributions of mechanised, motorised and non-mechanised sectors were 62%, 37% and 1% respectively. Annual per capita consumption of fish in Kerala is 27 kg, one of the highest among Indian states (The New Indian Express, 2015).

Fishing gears vary widely in their fuel requirements (Edwin & Hridayanathan, 1997; Boopendranth, 2000, 2008, 2012; Thrane, 2004a,b; Tyedmers *et al.*, 2005; FAO, 2007; Schau *et al.*, 2009; Winther *et al.*, 2009; World Bank & FAO, 2009; FAO, 2012a). Various fishing gears and practices ranging from artisanal to large-scale industrial systems are used for harvesting fish. Over the years, traditional fishing gears have been upgraded and newer more efficient fishing systems have been introduced. Major craft-gear combinations in the mechanised sector which are currently in operation in marine fisheries of Kerala, are shown in Table 1.4.

Table 1.4: Major craft-gear combinations in the mechanised fishing sector of Kerala

Mechanised fleet	Fishing gear
Mechanised trawler	Trawl nets (shrimp trawls, fish trawls, cephalopod trawls)
Mechanised gillnetter-liner	Gillnets; long lines; hand lines
Mechanised purse seiner/ ring seiner	Purse seines/ ring seines targeting specific pelagic fish stocks

Trawling has emerged as the most important method for exploiting demersal fisheries resources (Vivekanandan, 2003). Trawlers have become the mainstay of the fishing sector contributing about 50% of the total marine fish landings in India (Devaraj *et al.*, 1997; Devaraj & Vivekanandan, 1999; Bhathal, 2005). The total number of mechanised fishing vessels from Kerala along with its percentage is shown in Table 1.5.

Table 1.5: Mechanised fishing fleet in Kerala

Vessel category	Number	%
Trawlers	3678	77.89
Gillnetters	460	9.74
Liners	29	0.61
Ring seiners	495	10.48
Purse seiners	60	1.27
Total mechanised	4722	100

Source: CMFRI (2012)

Almost 78% of the total mechanised boats operating from Kerala are trawlers (CMFRI, 2012). Trawling is the most energy intensive fishing which consumes 1.8 to 11 times more fuel when compared to gillnetting, trapping, longlining, ring seining and purse seining for every kilogram of fish produced (Wiviott & Mathews, 1975; Leach, 1976; Edwardson, 1976; Lorentzen, 1978; Rawitscher, 1978; Nomura, 1980; Hopper, 1982; Gulbrandsen, 1986; Watanabe & Okubo, 1989; Aegisson & Endal, 1993; Edwin & Hridayanathan, 1997; Boopendranath, 2000, 2008, 2012; Thrane, 2004b; Norden, 2008; Winther *et al.*, 2009; Vivekanandan *et al.*, 2013).

Life Cycle Assessment (LCA) and Carbon Footprint (CF) studies will be useful for selecting energy efficient fishing systems and for delineating approaches for fuel conservation in fishing operations. It is important to undertake LCA and CF studies in order to enable the selection of green fishing systems and to reduce carbon footprint in fishing operations. In this study, LCA and CF estimation of trawlers, trawl gear systems and trawl caught fishes in Kerala are undertaken.

1.9 Objectives

Objectives of the present study were to:

- i. Investigate structural changes in the mechanised trawl fishing sector in Kerala in recent years
- ii. Study Life Cycle Assessment and Carbon Footprint of trawlers
- iii. Study Life Cycle Assessment and Carbon Footprint of trawl gear systems
- iv. Study Life Cycle Assessment and Carbon Footprint of trawl landings
- v. Identify hotspots and approaches to reduce environmental impact of the trawl fisheries

.....**SCA**.....

MATERIALS AND METHODS

2.1 Study area

Field visits and interviews using structured questionnaires were used to collect details of fishing vessel, fishing gear and operation (Annexure I). Fishing harbours and mechanised fish landing centres of Kerala, were visited during the study and details on design and construction of fishing vessels, gear, operation, engine and other relevant information were collected from boat yard operators, net makers, fishermen and other stakeholders from Cochin fisheries harbour, Munambam fisheries harbour, Munambam mini fisheries harbour, Kalamukku and Murikumpadam landing centres in Ernakulam district; Sakthikulangara and Neendakara in Kollam district and; Cheruvathur and Thaikadappuram in Kasaragod district (Fig. 2.1). About 58% of the trawlers operating from the state are from these areas (CMFRI, 2012).

2.2 Structural changes in trawlers

Analysis of structural changes in trawl fisheries in Kerala state was carried out by taking data on length overall and engine horsepower of mechanised trawlers operating in Kerala sourced from Fishing Vessel Registration Database of the Marine Products Export Development Authority (MPEDA). Data pertaining to 637 trawlers comprising 17% of total trawlers in the state, registered during 2008-2012, were considered for the study. Additional information regarding mechanised fishing vessels and engines were also collected from fishermen, dealers of marine engines, and boatyard operators. Details of vessel characteristics and horsepower in vogue during the

last decade were obtained from Boopendranath (2000). The data were analysed using standard statistical procedures (*viz.*, frequency analysis and exponential modelling) using SAS 9.3, in order to ascertain the decadal changes that have taken place in terms of vessel size and horsepower, in the mechanised trawl fisheries sector of Kerala.



Fig. 2.1 Landing areas selected for the study

2.3 Life cycle assessment and carbon footprint

Life Cycle Assessment (LCA) has arisen as a well-known and extensively used standardized environmental management tool to analyse the

environmental burdens along the life cycle of products and processes (ISO 14040, 2006a, 2006b). The International Organisation for Standardisation provides guidelines for conducting Life Cycle Assessment (LCA). Life Cycle Assessment (ISO 14040, 14044), is the compiling and evaluation of the inputs and outputs of a product system and their potential impacts on the environment during the product lifecycle. With LCA we can determine environmental hot spots of products or processes and use this information to improve the environmental performance at every stage of a product life cycle.

LCA consists of four stages.

- Goal and scope - Definition of the aim of the study, system boundaries and choice of impacts to be studied.
- Inventory - Data on all resource use defined in goal and scope are collected and quantified.
- Impact assessment - All resource use and emissions inventoried are grouped into chosen impact categories and weighted together based on their relative impact contribution potential.
- Interpretation of results

The Carbon Footprint is a measure of the exclusive total amount of Carbon Dioxide (CO₂) and other greenhouse gas (GHG) emissions that are directly or indirectly caused by an activity or is accumulated over the life stages of a product (EPLCA, 2007; Carbon Trust, 2008). This is usually expressed in kilograms of CO₂ equivalents.

GaBi-6 (Ganzheitlichen Bilanzierung) software (PE International, Leinfelden-Echterdingen) was used for Life Cycle Assessment (LCA) and Carbon Footprint analysis. The CML 2001 - Apr. 2013 method developed by the Centre

of Environment Science of Leiden University, Netherlands was used in order to perform the Life cycle impact assessment (LCIA) in GaBi-6 software.

Seven impact categories were included in this study:

Global warming potential (GWP)

Abiotic depletion potential (fossil) (ADP- fossil)

Acidification potential (AP)

Eutrophication potential (EP)

Ozone layer depletion potential (ODP steady state)

Photochemical ozone creation potential (POCP)

Marine aquatic ecotoxicity potential (MAETP).

The impact categories for the global warming potential and ozone layer depletion are based on IPCC factors (PAS 2050, 2011).

2.3.1 Global warming potential

The concept of Global Warming Potential (GWP) was introduced in 1990 to compare emissions of different greenhouse gases over a given time horizon. GWP is a relative measure of how much heat a greenhouse gas (CO₂, CH₄, N₂O, CFCs, etc.) traps in the atmosphere. The global warming potential is calculated in Carbon dioxide equivalents (CO₂ Equiv.). Since the residence time of the gases in the atmosphere is incorporated into the calculation, a time range for the assessment has been taken as 100 years which is customary.

2.3.2 Abiotic depletion potential

Abiotic resource depletion includes depletion of non-renewable natural resources, i.e. fossil fuels, metals and minerals. The Abiotic Depletion Potential of fossil fuel is represented in (mega joules) MJ. This impact

category describes the reduction of the global amount of non-renewable raw materials, in a time frame of at least 500 years.

2.3.3 Acidification potential

The major acidifying pollutants are SO₂, NO_x, HCl and NH₃. Acid rain is one form in which acid deposition occurs. Fog, snow and dew also trap and deposit atmospheric pollutants. Acidification potential reflects the maximum acidification a substance can cause. Examples of impacts are fish mortality, leaching of toxic metals out of soil and rocks, damage to forests and damage to building and monuments (Harrison, 1990). The acidification potential is given in Sulphur dioxide equivalents (SO₂ Equiv.).

2.3.4 Eutrophication potential

Eutrophication is the enrichment of nutrients in a certain region. Air pollutants, waste water, river runoff, etc. contribute to eutrophication. Oxygen depletion is a common effect of eutrophication in water. Decreased oxygen concentration in the water, can eventually lead to fish mortality and to anaerobic decomposition. Hydrogen sulphide and methane are thereby produced. This can lead, among others, to negative impacts on the eco-system. Nitrite, a reaction product of nitrate, caused by Eutrophication is toxic to humans. The eutrophication potential is calculated in Phosphate equivalents (PO₄ Equiv.).

2.3.5 Marine aquatic ecotoxicity potential

Marine aquatic ecotoxicity refers to the impact of toxic substances emitted to marine aquatic ecosystems. The marine aquatic ecotoxicity potential is given in 1,4-Dichlorbenzol equivalents (DCB Equiv.).

2.3.6 Ozone layer depletion potential

Ozone (O₃) is an essential substance in the upper atmosphere, the stratosphere, where it screens out more than 99% of the dangerous ultraviolet radiation from the sun. Anthropogenic emissions deplete ozone, forming holes in the layer ultimately leading to effects such as warming of the earth's surface and decrease in plankton biomass, which would strongly affect the food chain. The ozone depletion potentials (ODPs) used in LCA were developed by the World Meteorological Organisation (WMO) which updates its list of ODPs periodically. The ozone depletion potential is calculated in Trichlorofluoromethane equivalents (R11 Equiv.).

2.3.7 Photochemical ozone creation potential

Despite playing a protective role in the stratosphere, at ground-level ozone is classified as a damaging trace gas. Photochemical ozone production in the troposphere, also known as summer smog, is suspected to damage vegetation and material. High concentrations of ozone are toxic to humans. High concentrations of ozone arise when the temperature is high; humidity is low, when air is relatively static and when there are high concentrations of hydrocarbons. Hydrocarbon emissions occur from incomplete combustion, in conjunction with petrol or from solvents. In Life Cycle Assessments, photochemical ozone creation potential is represented in Ethylene Equiv.

For the analysis of Life Cycle Assessment of mechanised trawl fishing operations, the entire process was separated into three subsystems *viz.*, Fishing Sub-system I (fishing vessel construction and maintenance); Fishing Sub-system II (trawl net construction and maintenance); and Fishing Sub-system III (fishing operation) (Fig. 2.2). In this study, cradle to gate approach has been followed and mass allocation was considered. For each subsystem, the

amount of material used in one year was obtained and corresponding amount of impact assessment was determined using GaBi 6 database. The capital items such as fishing vessel, machinery and equipment; and fishing gear are amortised over their anticipated useful lifetimes. Representative samples from each category of vessel and gear were examined, to collect design and operational details.

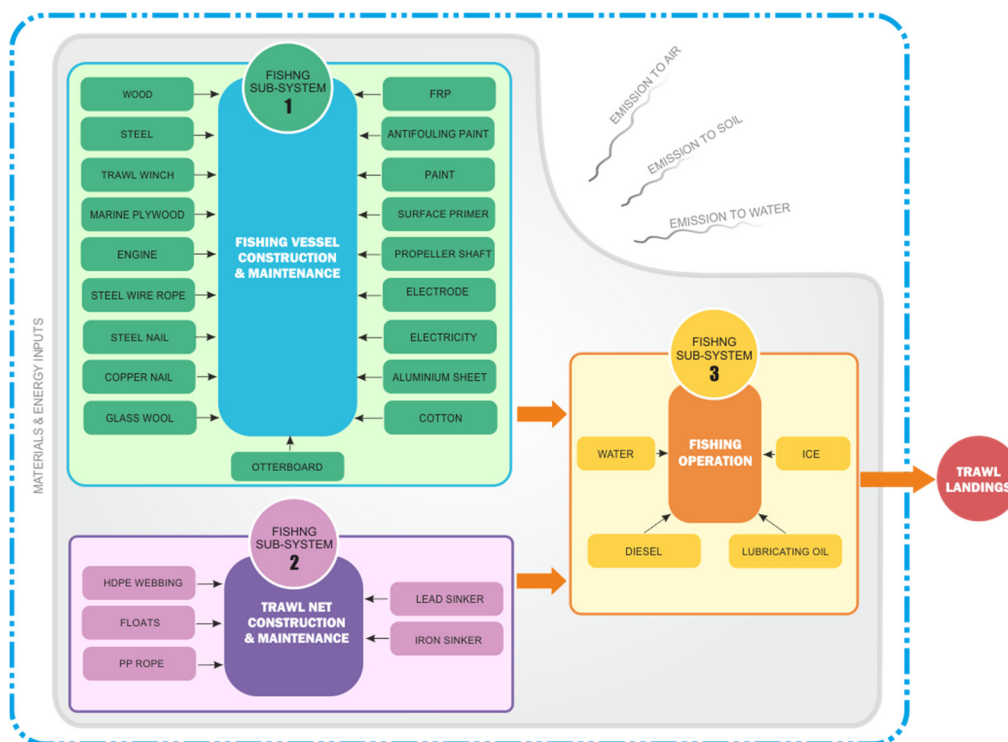

Fig. 2.2 System boundaries for life cycle assessment of mechanised trawl fishing operations

2.3.8 Data sources for life cycle assessment and carbon footprint

2.3.8.1 Fishing vessels

Information of mechanised trawlers were collected from boat builders as per the structured schedule prepared for the purpose. Quantity of material requirements for construction were estimated using the methods described by Fyson (1985; 1991). The material inputs for maintenance of wooden and steel

trawlers were obtained from boatyards, fishermen, dealers of marine engines and manufacturers of otterboards and propellers, through pre-tested structured questionnaires (Annexure II). The material inputs for mechanised trawl vessel manufacture were converted to corresponding impact values using GaBi database (GaBi-6). Trawlers of different size categories are shown in Table 2.1 and data from 15 types of trawlers coming under different L_{OA} were selected for the analysis. This selection has been done based on the length frequency analysis of trawlers operated in Kerala.

Table 2.1: Different categories of trawlers

Type of trawlers	L _{OA} (m)	Material of construction
Small trawlers	< 12	Wood
Medium trawlers	12 - 16	Wood, Steel
Large trawlers	16 -24	Wood, Steel
Very large trawlers	> 24	Steel

They are 10.66 m small wooden single day trawler, 13.71 m medium wooden multiday trawler, 15.3 m medium wooden multiday trawler, 18.9 m large wooden multiday trawler, 19.81 m large wooden multiday trawler, 21.33 m large wooden multiday trawler, 13.71 m medium steel multiday trawler, 15.3 m medium steel multiday trawler, 18.9 m large steel multiday trawler, 19.81 m large steel multiday trawler, 21.33 m large steel multiday trawler, 22.86 m large steel multiday trawler, 24.38 m very large steel multiday trawler, 25.9 m very large steel multiday trawler and 27.43 m very large steel multiday trawler. Quantitative information on different materials used for trawler construction were collected and it comprises of use of steel in vessel hulls, trawl winch, engine, steel wire rope, steel nail, otterboards, copper nail, wood, marine plywood, FRP, surface primer, paint, antifouling paint, welding electrode, electricity, aluminium sheet, cotton, propeller shaft and propeller.

Useful life-time of both wooden and steel trawlers were assumed to be 15 years for amortisation purposes. Average service life of steel wire ropes were estimated as 3 years and 9 months from the present study. An addition of 5% were added on the steel nails, copper nails, welding rod, PUF and FRP used for the vessel construction to incorporate the inputs for maintenance during its life cycle. An addition of 10% were added on the wood, plywood, steel hull, electricity, cotton and aluminium sheet used for the vessel construction to incorporate the inputs for maintenance during its life cycle. It was assumed that, there is no replacement or change in the engine, trawl winch, propeller shaft and propeller during the life span of trawlers. It was assumed that, primer is applied only once in every five years and three years in wooden and steel trawlers respectively. Paint and antifouling paints were applied to the trawlers yearly. For wooden and steel otterboards, service life were one and three years respectively.

Timber used for construction are usually Anjili (*Artocarpus hirsutus*), Red Gum (*Eucalyptus camaldulensis*) and Tamarind (*Tamarindus indica*). Propeller was made of gunmetal.

2.3.8.2 Fishing gear

Data on design details and rigging of trawl gears were obtained by a survey of fishing gears operated from fish harvesting systems selected for the study, as per a structured schedule prepared for the purpose (Annexure III). Commonly used trawl nets along Kerala coast falls under 15 different categories viz., 39.6 m fish trawl, 53.8 m fish trawl, 72.0 m fish trawl, 76.5 m fish trawl, 81.0 m fish trawl, 85.6 m fish trawl, 33.4 m cephalopod trawl, 45.6 m cephalopod trawl, 54.0 m cephalopod trawl, 57.6 m cephalopod trawl, 34.2 m shrimp trawl, 39.6 m shrimp trawl, 40.0 m shrimp trawl, 51.0 m shrimp trawl and 58.0 m shrimp trawl are considered during the study for analysis.

The gear designs were documented following FAO conventions (FAO, 1975; 1978; Nedlec, 1982). Sources of material inputs to gear manufacture were estimated from design drawings. Netting requirements were estimated as per method described by Hameed & Boopendranath (2000) using the following formula and by adding 5% weight to compensate for the wastage during fabrication or obtained by direct inquiries from the gear fabricators:

$$W_n = \{K \cdot [(M_{t1} + M_{t2}) / 2] \cdot M_n \cdot 2m \cdot 10^{-3}\} \cdot R\text{-tex} \cdot 10^{-6}$$

where W_n = the weight of the netting (kg) of each of the component sections constituting the netting panels of the gear system with a uniform mesh size, twine size and material specifications

M_{t1} and M_{t2} = number of meshes in width along the top and bottom edges

M_n = number of meshes in depth

m = stretched mesh size in mm

K = correction factor for length of twine used in a knot

= length of twine used in a knot in mm / 2m

R-tex = linear density of netting twine ($\text{g} \cdot \text{km}^{-1}$)

Useful life-time of HDPE webbing materials, polypropylene ropes and iron sinkers for trawls estimated for amortisation purposes were 1 year. Service life of lead sinkers were estimated as 2 years and 6 months and that of HDPE floats as 9 months.

2.3.8.3 Operational details

Data on operational details were collected from trawlers for a period of one year (June 2012 - May 2013). Till date, most seafood LCA studies reported their results referred to short periods of time, usually, one year, regarding the

fishery stage of the process, due mainly to the difficulty to collect comprehensive data (Vázquez-Rowe *et al.*, 2012b). Sampling centres were selected based on dominance of the trawlers and accessibility based on subjective sampling technique. Major inputs for mechanised trawling operations were fuel, lubricating oil, water and ice for preservation of fish. The operational details of 15 types of trawlers *viz.*, 10.66 m small wooden single day trawler, 13.71 m medium wooden multiday trawler, 15.3 m medium wooden multiday trawler, 18.9 m large wooden multiday trawler, 19.81 m large wooden multiday trawler, 21.33 m large wooden multiday trawler, 13.71 m medium steel multiday trawler, 15.3 m medium steel multiday trawler, 18.9 m large steel multiday trawler, 19.81 m large steel multiday trawler, 21.33 m large steel multiday trawler, 22.86 m large steel multiday trawler, 24.38 m very large steel multiday trawler, 25.9 m very large steel multiday trawler and 27.43 m very large steel multiday trawler based on different length were collected on every landing day from June 2012 to May 2013 for the LCA analysis. Data on fishing operations were collected by discussions with the operators as per a structured schedule prepared for the purpose and short onboard visits (Annexure IV). Life cycle assessment values for the mechanised single-day and multi-day trawl fishing operations were scaled up for entire mechanised trawl fishing operation from Kerala using estimates of number of active trawlers in single-day and multi-day category in Kerala, based on data sourced from Fishery Resources Assessment Division of Central Marine Fisheries Research Institute (CMFRI), Fishing Vessel Registration Database of the Marine Products Export Development Authority (MPEDA) and from survey conducted under the present study. In the estimates of fish landings, certain sources of uncertainty such as illegal, unreported or unregulated (IUU) fishing activities are difficult to tackle and the potential wastes that can arise during fishing activities, such as discards,

slipping or offal wastes are difficult to retrieve (Kelleher, 2005; Stratoudakis & Marcalo, 2002). Under such circumstances, Vázquez-Rowe *et al.* (2012b) recommended the use of average previous estimates from published literature. In this study, data on trawler landings for the corresponding sectors, single-day and multi-day operations sourced from CMFRI database, for the period of investigation, were used for estimation of Global warming potential, Abiotic depletion potential (fossil), Acidification potential, Eutrophication potential, Ozone depletion potential, Photochemical ozone creation potential and Marine aquatic ecotoxicity potential per tonne of marine fish landed.

Annexure I
Details of fishing craft and gear

1	Area		Date	
2	Name of trawler:		Registration No.	
3	Owners name:		Contact No.	
4	Address:			
	Structural details			
5	LOA (m)			
6	Breadth/ Beam max. (m)			
7	Depth (m)			
8	Year built			
9	Boat construction material		Wood / Steel	
10	Make of engine		HP	Model No.
11	Wireless Yes/No	GPS Yes/No	Echo sounder Yes/No	
12	Propeller size	No. of blade	Weight	Material
13	Deck equipment	Trawl winch	Net drum	
14	Tonnage of the vessel			
15	Boat construction yard name, address & contact No.			
16	No. of man days for construction			
17	Diesel capacity:	Water capacity:	Fish hold capacity:	
18	Paints	Frequency of painting	Quantity used	
19	Antifouling paints	Frequency of antifouling paint	Quantity used	
20	No. of battery 12V/24V			
21	Lub oil used per month	Grease used per month		
22	Plastic/fibre boxes used			
23	Anchor (No.) & weight		Chain weight	
24	Winch type & weight	Material	SWR length, dia. & material	

Gear Details					
25	Type of nets with HR length	Mesh size (wing & codend)	No.	Floats Dia. x L, Wt & material	Sinkers Dia. x L, Wt & material
26	Service life of different types of net				
27	Name & contact No. of net maker				
28	No. of man- days taken for construction				
29	Otterboard material	Service life	Type and dimension	Weight	
30	Quantity of webbing damaged/replaced per year				
Operational details					
31	Fishing port				
32	Duration of fishing trip	Avg. No. of operations per day/night			
33	Average duration of one operation				
34	Fishing area & depth range of fishing operation				
35	Fuel consumption in one fishing trip				
36	Cruising speed:			Fishing speed:	
37	Fuel consumption/day (Avg.)				
38	Number of fishing days (Avg.)			Time of operation	
39	Catch details & season				
40	Total crew onboard				
41	Average operational requirements per trip <ul style="list-style-type: none"> • HSD (litre) • Lub oil (litre) • Water (litre) • Ice (No. of blocks) 				
42	Landing area and catch disposal				

Annexure II

Details of material inputs into construction of mechanised trawler

General Information			
Name and registration number:			
LoA, m			
Beam max, m			
Depth, m			
Location and date			
1.0 Mechanised trawler			
	Item	Material	Quantity
1.1	Hull - skin and frames		
1.2	Hull strength members (Keel, deadwood, engine bearers, stringers, etc.)		
1.3	Deck (deck, deck beams)		
1.4	Wheel house		
1.5	Outfit (Joiner work, fish hold lining and insulation, masts, rigging, fuel tanks etc.) & appendages		
1.6	Fastenings (for wooden construction) Welding (for steel construction)		
1.7	Machinery (Main engine, shafting, propeller & net drum)		
1.8	Deck equipment (Trawl winch)		
1.9	Aluminium sheathing (for wooden hulls)		
1.10	Fish hold (PUF) material & Fibreglass		
1.11	Quantity of Welding rods		
1.12	Electricity for lighting and welding (kWh)		
1.13	Paint (zinc chromate) & other paints		
1.14	Antifouling paint		

Annexure IV

Operational inputs of mechanised trawl harvesting systems

Name of Fishing vessel:	Registration No:
	LOA of Vessel (m):
Horsepower:	
Type, No. and size of Fishing gear:	

Account of fishing trips, diesel, lub oil, ice and water

Starting date :						
Diesel at hand (litres) :						
Lub oil at hand (litres) :						
Departure from port Date & Time	Arrival to port Date & Time	Diesel, Litres	Lub oil, Litres	Ice, kg	Water, Litres	Area & depth of fishing
Finishing date (after 12 months):						
Diesel at hand (litres) :						
Lub oil at hand (litres) :						

.....*DCS*.....

STRUCTURAL CHANGES IN THE TRAWL FISHING SYSTEMS

3.1 Introduction

In India, fisheries is an important sector which plays a significant role in creating job opportunities, enhancing income and foreign exchange earnings and availability of protein rich food. India has been ranked fifth in the world capture fishery production, during 2011 (FAO, 2013). The annual potential yield from the Exclusive Economic Zone (EEZ) of India has been recently re-validated at 4.42 million t, of which 3.84 million t is from the zone up to 100 m depth and 0.58 million t is from deeper waters (GOI, 2011). The marine catch of 3.82 million t (2011) (CMFRI, 2013a) forms 86.45% of the re-validated fishery potential and is largely derived from the intensively fished coastal zone.

Kerala state, situated in the Southwest coast of India, has traditionally been the foremost fishery area of the Indian sub-continent (CMFRI, 2013a). It has a coastline of 590 km and a continental shelf area of 39,139 sq km. Kerala ranked first in marine fish production among maritime states of India, contributing about 19% of the total marine landings (0.74 million t), during 2011 (CMFRI, 2013). Marine fishing fleet in Kerala consists of 4,722 (21.7%) mechanised, 11,175 (51.3%) motorised and 5,884 (27.0%) non-motorised fishing vessels (CMFRI, 2012). The marine landings are mainly contributed by the mechanised (56%) and motorised (42%) sectors (Mohamed *et al.*, 2013). With increasing fishing pressure in the coastal waters, fishermen

operating in mechanised sector are forced to go to deeper waters in search of newer fishing grounds in order to maintain their catches. Marine capture fisheries, in Kerala, have gone through significant changes since 1950s and the changes in number and capacities of fishing vessels have been more pronounced in the last decade. Excess fleet capacity and increased fuel consumption by the mechanised fisheries have been worsening over the years. In this chapter, an attempt has been made to compare the structural changes that has taken place, in terms of length overall (L_{OA}) and installed engine horsepower, in the trawl fishing sector of Kerala, over the last decade.

3.2 Materials and methods

Data on length overall and engine horsepower of mechanised trawlers operating in Kerala were sourced from Fishing Vessel Registration Database of the Marine Products Export Development Authority (MPEDA). Data pertaining to 637 trawlers comprising 17% of total trawlers in the state, registered during 2008-2012, were considered for the study. Additional information regarding mechanised fishing vessels and engines were also collected from fishermen, dealers of marine engines, and boatyard operators. Details of vessel characteristics and horsepower in vogue during the last decade were obtained from Boopendranath (2000). The data were analysed using standard statistical procedures (*viz.*, frequency analysis and exponential modelling) using SAS 9.3, in order to ascertain the decadal changes that have taken place in terms of vessel size and horsepower, in the mechanised trawl fisheries sector of Kerala.

3.3 Results

The growth of mechanised fishing fleet in Kerala, during 1980-2010 period, is given in Fig. 3.1. The number of mechanised vessels increased from

983 in 1980, to 5088 in 1998, 5504 in 2005 and decreased to 4722 in 2010 (CMFRI 1981; CMFRI, 2006; DOF 2007; CMFRI, 2012). Trawlers constituted 76% of the mechanised fleet of Kerala in 1980, 88% in 1998 and 72% in 2005. In 2010, trawlers constituted about 77.9% of the total mechanised fleet of Kerala, followed by purse seiners and mechanised ring seiners (11.8%), gillnetters (9.7%) and liners (0.6%) (CMFRI, 2012). There were about 8 mechanised vessels per kilometre of coastline in Kerala, during 2010.

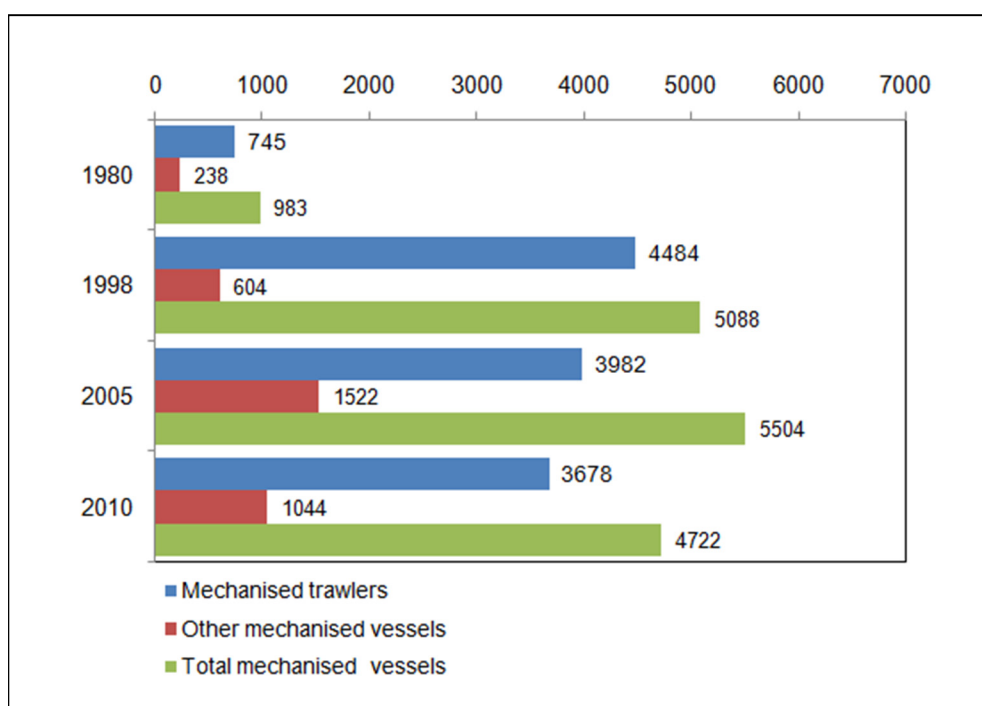

Fig. 3.1. Increase in number of mechanised trawlers, other mechanised vessels and total marine fishing fleet in Kerala during 1980-2010 (Source: CMFRI 1981, 2006 & 2012; DOF 2007)

About 3,678 trawlers are operating from Kerala (CMFRI, 2012) and the fleet consists of small, medium and large trawlers (Kurup *et al.*, 2009). Trawling is the most demanding fishing method in terms of energy consumption when compared to gillnetting, longlining, ring seining and purse seining (Gulbrandsen, 1986; Aegisson & Endal, 1993; Boopendranath, 2009).

3.3.1 Frequency distribution in length classes

A comparison of frequency distribution of length classes of trawlers operating from Kerala is given in Fig. 3.2. During the year 2000, almost 56% of trawlers were of length class 13-14 m L_{OA} , followed by 12-13 m (12.3%), 11-12 m (9.1%), 14-15 m (8.4%), 10-11 m (5.8%), 15-16 m (4.6%) and 9-10 m (3.9%). During 2012, the most dominant length class (40.6%) was 19-20 m L_{OA} , followed by 20-21 m (15.9%), 18-19 m (10.7%), 17-18 m (6.1%), 21-22 m (5.2%) and representation by other length classes were below 4%. During 2012, length classes ranged from 9-10 m to 22-23 m L_{OA} , whereas during 2000, the range extended from 9-10 m to 15-16 m L_{OA} , showing a significant shift in the preferred size of trawlers.

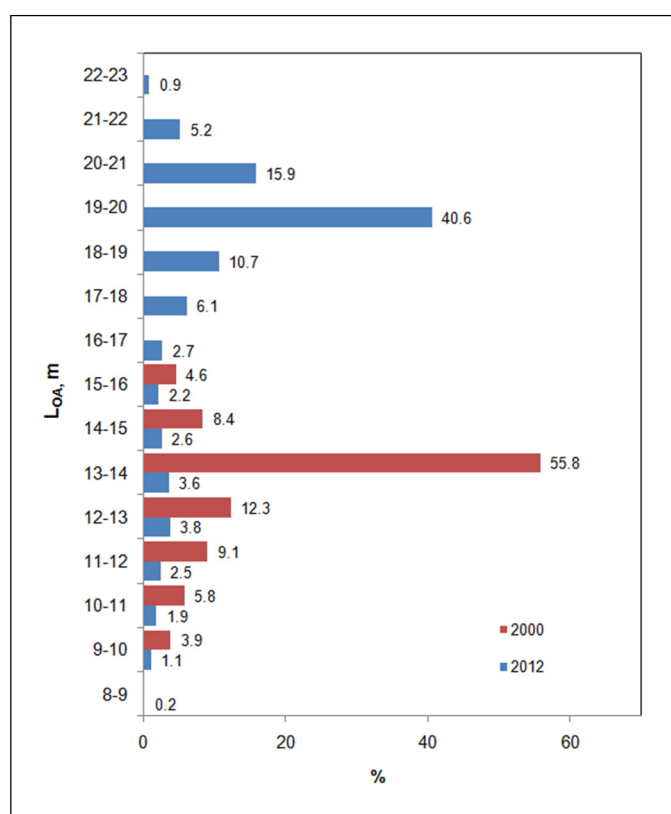

Fig. 3.2 Frequency distribution of length classes of trawlers in Kerala

3.3.2 Frequency distribution in installed engine horsepower

Frequency distribution of engine horsepower (hp) of trawlers, during 2000 and 2012 are represented in Fig. 3.3. The engine horsepower in trawlers, during the year 2000, ranged between 50 and 150 hp, whereas in 2012, engine horsepower extended up to 495 hp. Engines with 100-150 hp were widely used (62.3%) during 2000, followed by engines with 50-100 hp (37.5%). During 2012, 24.7% of the trawlers were using engines with 100-150 hp, 18% with 150-200 hp, 16.8% with 300-350 hp and 16.2% with 250-300 hp. Trawlers with engines higher than 350 hp were 13.7% and those using less than 100 hp were 5.3%. Use of high horsepower engines in trawlers coincided with the adoption of high speed trawling using fish trawls with large trawl mouth and having large meshes in the front trawl panel sections, for harvesting fast moving fishes.

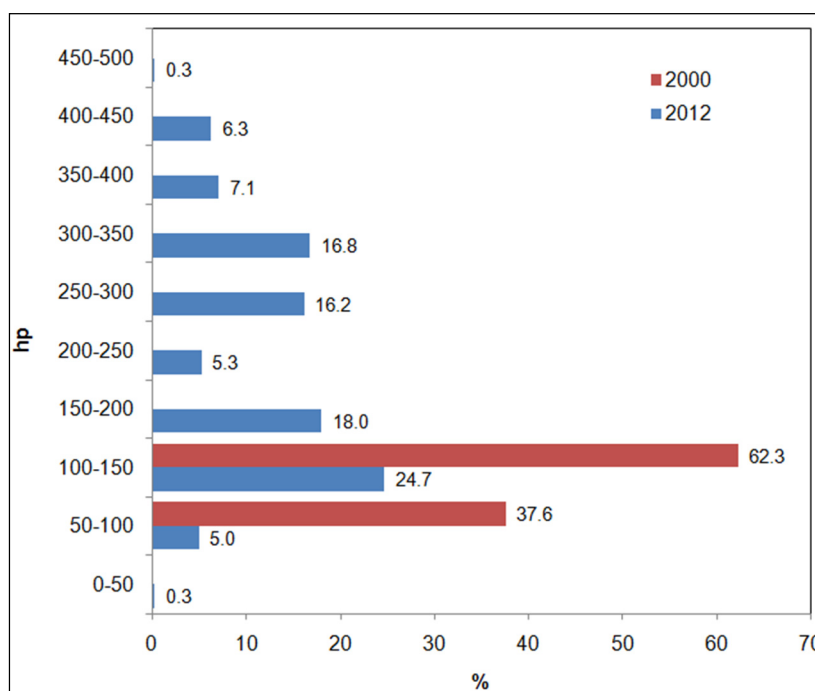

Fig. 3.3. Frequency distribution of installed horsepower of trawlers in Kerala

3.3.3 Relationship between length and engine horsepower of trawlers

Relationship between length and engine horsepower of trawlers during the year 2012 is given in Fig. 3.4. The scatter plot of overall length vs. engine horsepower of trawlers exhibited an exponential relation. The simple exponential function of the form Engine horsepower = $a \cdot \exp(b \cdot \text{length})$ was fitted by Levenberg marquardt algorithm using SAS 9.3. The resultant model is given by the equation,

$$\text{Engine horsepower} = 14.625 \cdot \exp^{0.147 \cdot \text{LOA}}; R^2 = 0.602$$

Fig. 3.4 explains the relationship between engine horsepower and length overall, with moderate R^2 value in terms of observed and predicted value. The rate of change of engine horsepower (hp) was 0.147 with respect to change in the L_{OA} . The exponential growth of engine horsepower was evident in trawlers with L_{OA} greater than 18 m.

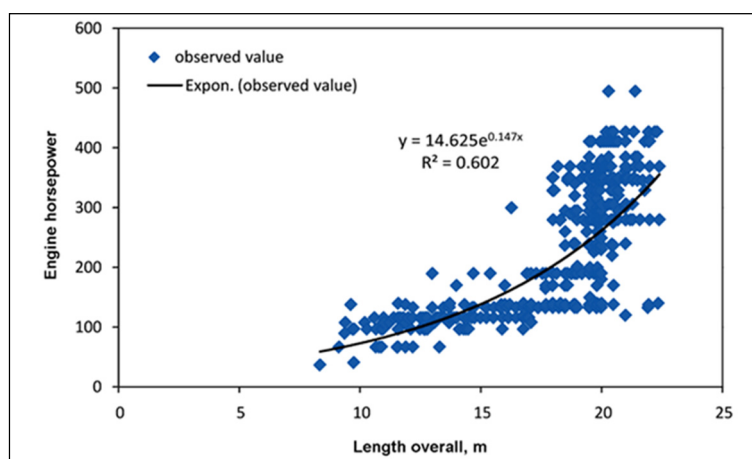

Fig. 3.4. Relationship between length and engine horsepower of trawlers during 2012

3.3.4 Frequency distribution of makes of engines

Frequency distribution of different makes of engines installed in trawlers operating from Kerala, during 2012 is given in Fig. 3.5. Marine diesel

engines from 13 different manufacturers were prevalent. Indigenous type I (India) marine diesel engines were most popular (57.3%), followed by Imported type I (China) (15.9%), Imported type II (China) (14.8%), Imported type III (USA) (3.5%), Imported type IV (China) (2.8%), Imported type V (China) (2.5%) and Imported type VI (USA) (1.4%). Representation of Imported type VII (UK), Indigenous type II (India), Imported type VIII (China), Imported type IX (Brazil), Imported type X (Japan) and Collaborated type I (India and USA) were 0.5% or less. Ashok Leyland (India) collaborates with Weichai Power (China) in marketing marine diesel engines in India.

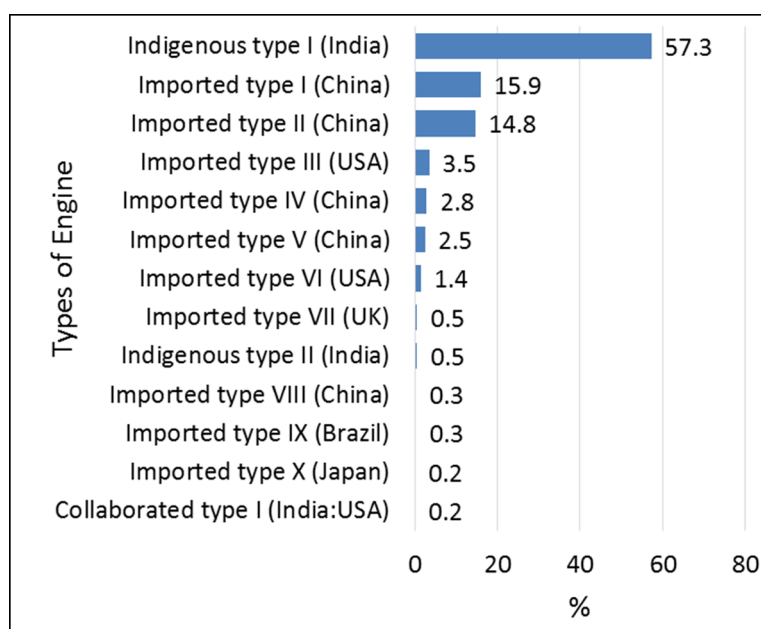

Fig. 3.5. Frequency distribution of different types of engines installed in trawlers operating from Kerala, during 2012

3.4 Discussion

A decade ago, fishing vessels in Kerala were largely dependent on marine diesel engines of Indian origin with horsepower rating up to 193 hp, for powering the mechanised vessels (Boopendranath, 2000). During the last

4-5 years, there is an increasing tendency among the operators of trawlers to install high horsepower engines (Baiju *et al.*, 2012; Mohamed *et al.*, 2013). Majority of high horsepower engines used in mechanised vessels of Kerala include Chinese makes such as Sinotruk, Weichai Power, Yuchai and Shanghai and high horsepower engines from Ashok Leyland marketed in collaboration with Weichai Power (China).

Optimum fleet size of mechanised vessels for marine fishing off Kerala were estimated at 3030 and 3143, respectively, by Kurup & Devaraj (2000) and Sathianandan *et al.* (2008). According to these estimates, the existing number of mechanised vessels in Kerala (CMFRI, 2012) are in excess by 50-55% than optimum fleet size. A recent estimate based on revalidated potential yield of fishery resources in the Indian Exclusive Economic Zone has given optimum mechanised fleet size as 4032 for Kerala, consisting of 3610 trawlers, 316 purse seiners and mechanised ring seiners and 72 gillnetters (Mohamed *et al.*, 2013). According to this estimate, the existing number of mechanised vessels in Kerala (CMFRI, 2012) are in excess by about 17% than required fleet size.

Though the number of mechanised fishing vessels in Kerala has shown a decrease by 14%, between 2005 and 2010 census periods (CMFRI, 2006; 2012), fishing power of a considerable percentage of individual fishing units has significantly increased due to increase in installed engine horsepower, vessel capacities, improved navigation and fish detection capabilities and improved efficiency of fishing gear systems, in recent years, as evident from the present study and other studies (Boopendranath, 2009; Kurup *et al.*, 2009; Pillai *et al.*, 2009; Baiju *et al.*, 2012; Mohamed *et al.*, 2013). The results of the present study points to the need for optimizing and regulating capacities of the fishing vessels based on their area/depth of operation, in order to mitigate

negative impacts on resources, conserve fuel and reduce greenhouse gas (GHG) emissions, which has been highlighted in several studies (Bhathal & Pauly, 2008; Boopendranath, 2009; 2012; Kurup *et al.* 2009; Baiju *et al.*, 2012; Mohamed *et al.*, 2013).

3.5 Conclusion

The results have demonstrated large scale changes in the structure of the mechanised fishing fleet of Kerala, both in terms of size and installed engine horsepower among trawlers, during the last decade. The study indicated an exponential increase in engine horsepower among trawlers above 18 m in L_{OA}, in recent years. With increasing fishing pressure in coastal waters and diminishing returns, the area of operation of mechanised fleet has further extended to deeper waters and vessels with larger size, power and capacities equipped for multi-day fishing have become popular. The study also suggests the need to account for the increase in the fishing capacity of the vessels while planning for fishing fleet restrictions.

..........

LIFE CYCLE ASSESSMENT AND CARBON FOOTPRINT OF TRAWLERS

4.1 Introduction

Trawling was introduced in Kerala in mid 1950s and has become one of the most important commercial fishing methods in mechanised sector. As per CMFRI Marine Fisheries Census 2010, a total of 3678 mechanised trawlers are operating in Kerala coast (CMFRI, 2012). A trawler is a specific fishing vessel type which is equipped to tow one or more trawl nets. It is provided with engine of sufficient power to tow the net at the appropriate trawling speed, and is fitted with trawl winches and equipment necessary to haul the net on board and lift the codend over the deck. In stern trawling, which is the most popular method of trawling in recent years, the warps are led from the trawl winch through two towing blocks attached to stern gallows. The wheel house is situated in the forward part of the vessel and the trawl winch is placed, behind the wheel house.

Non-availability of quality timber at reasonable price, difficulties in the maintenance of wooden crafts, and the availability of steel of the required grade, have increased the acceptance of steel as a construction material for trawlers. During the period of study, about 80 % of the multi-day trawlers operating from Kerala had steel hulls and the rest were of wooden hull construction. Because of the special net towing function, trawlers have different design requirements from those vessels engaged in handling of static fishing gear such as line and gill nets or from the vessels which must encircle a school of fast moving fish, as

a primary function of fishing (Fyson, 1991). In a typical bottom trawl system, about 20% of the drag is contributed by the otter boards, another 10% by sweeps and bridles, and the balance by the trawl and its rigging (Wileman, 1984; Fridman, 1986; Fyson, 1985; Seafish *et al.*, 1993). Trawlers are classified into four categories, *viz.*, small trawlers, medium trawlers, large trawlers and very large trawlers based on the L_{OA} using general classification and regression tree model analysis (Edwin *et al.*, 2014a) (Table 4.1).

Table 4.1: Classification of trawlers based on L_{OA}

Type of trawlers	L_{OA} (m)
Small trawlers	< 12
Medium trawlers	12 - 16
Large trawlers	16 - 24
Very large trawlers	> 24

4.2 Materials and methods

Life Cycle Assessment (LCA) has been used previously for seafood products and has proved to be a useful environmental management tool for fishery performance evaluation (Pelletier *et al.*, 2007). In this chapter, LCA of trawlers coming under different categories based on L_{OA} and material of construction are considered. GaBi-6 software (PE International, Leinfelden-Echterdingen) was used for Life Cycle Assessment (LCA) and Carbon Footprint analysis. Seven important parameters *viz.*, Global warming potential (GWP), Abiotic depletion potential (fossil) (ADP-fossil), Acidification potential (AP), Eutrophication potential (EP), Marine aquatic ecotoxicity potential (MAETP), Ozone depletion Potential (ODP) and Photochemical ozone creation potential (POCP) were considered in this chapter. Detailed description of the parameters are mentioned in Chapter 2.

Material and energy inputs to trawl vessel construction and maintenance and their contributions to the environmental impacts have been analysed in this chapter to quantify impacts associated with use of steel in vessel hulls, trawl winch, engine, steel wire rope, steel nail, otterboards, copper nail, wood, marine plywood, FRP, surface primer, paint, antifouling paint, welding electrode, electricity, aluminium sheet, cotton, propeller shaft and propeller (Fig. 4.1). 15 different types of fishing vessels *viz.*, 10.66 m small wooden single-day trawler, 13.71 m medium wooden multi-day trawler, 15.3 m medium wooden multi-day trawler, 18.9 m large wooden multi-day trawler, 19.81 m large wooden multi-day trawler, 21.33 m large wooden multi-day trawler, 13.71 m medium steel multi-day trawler, 15.3 m medium steel multi-day trawler, 18.9 m large steel multi-day trawler, 19.81 m large steel multi-day trawler, 21.33 m large steel multi-day trawler, 22.86 m large steel multi-day trawler, 24.38 m very large steel multi-day trawler, 25.9 m very large steel multi-day trawler and 27.43 m very large steel multi-day trawler were considered for the study.

Information of mechanized vessels were collected from boat builders as per the structured Schedule prepared for the purpose. Quantity of material requirements for construction were estimated using the methods described by Fyson (1985; 1991). The material inputs for maintenance of wooden and steel trawlers were obtained from boatyards, fishermen, dealers of marine engines, otterboards and propeller making workshops, through pre-tested structured questionnaires. The material inputs for mechanized trawl vessel manufacture were converted to corresponding impact values using Gabi database. Trawlers of different size classes and material of construction are shown in detail in chapter 2

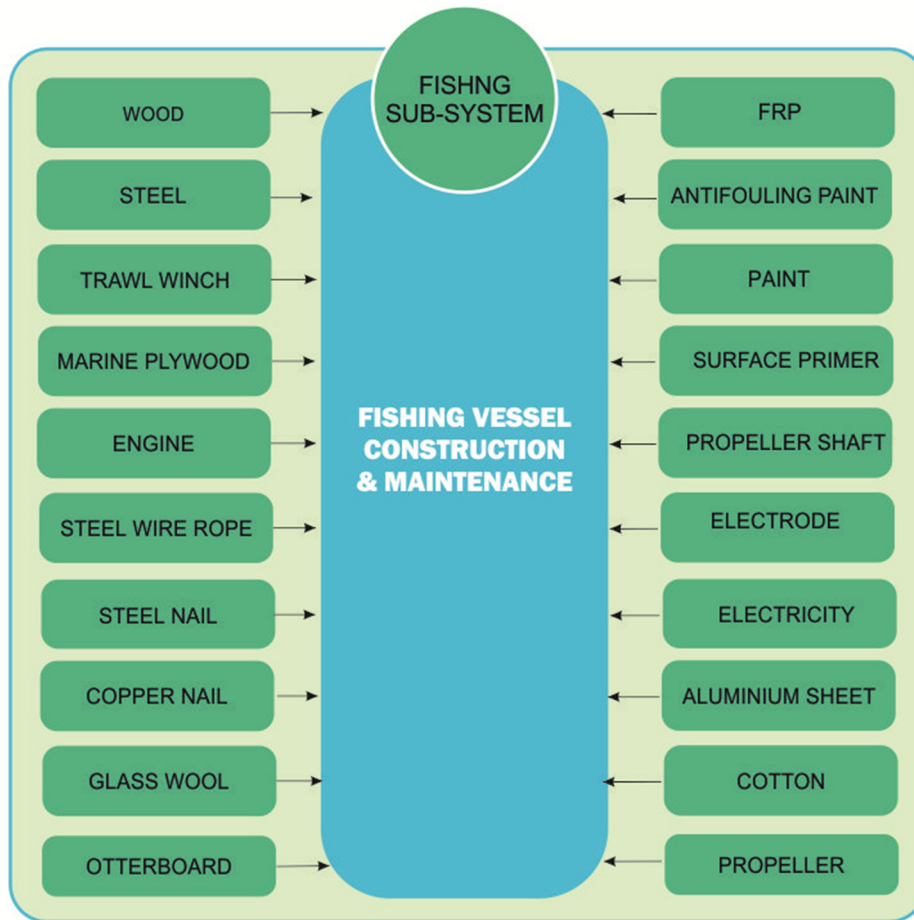

Fig. 4.1 Material inputs to fishing vessel construction and maintenance

Useful life-time of both wooden and steel trawlers were assumed to be 15 years for amortisation purposes. Average service life of steel wire ropes were estimated as 3 years and 9 months. An addition of 5% were added on the steel nails, copper nails, welding rod, glass wool and FRP used for the vessel construction to incorporate the inputs for maintenance during its life cycle. An addition of 10% were added on the wood, plywood, steel hull, electricity, cotton and aluminium sheet used for the vessel construction to incorporate the inputs for maintenance during its life cycle. It was assumed that, there is no replacement or change in the engine, trawl winch, propeller shaft and propeller

during the life span of trawlers. It was assumed that, primer is applied only once in every five years and three years in wooden and steel trawlers respectively. Paint and antifouling paints were applied to the trawlers yearly. The values of antifouling paints are assumed to be same as for paints in this study. For wooden and steel otterboards, service life were one and three years respectively.

Timber used for construction are usually Anjili (*Artocarpus hirsutus*), Red Gum (*Eucalyptus camaldulensis*) and Tamarind (*Tamarindus indica*). Propeller was made of gunmetal.

4.3 Results

This Chapter focuses on Fishing Sub-system I, with trawler as functional unit.

4.3.1 Trawlers of Kerala

Commercial trawlers in Kerala are mostly in the size range of 10.66 to 24 m L_{OA} but recently trawlers up to 28 m L_{OA} have also been introduced. Trawling industry in Kerala started with small wooden trawlers and later large sized steel trawlers were introduced. Most of the large steel trawlers have two fuel tanks with a total capacity of 1500 - 8000 litres. Trawlers are equipped with onboard gear handling equipment such as winch, fishing gallows, mast and boom, navigational equipment such as Global Positioning System (GPS), echo sounder and Very High Frequency (VHF) transceiver. Most of the vessels are dry docked once in a year and antifouling paints are applied on the under water hull area. In a few vessels, net drums have been recently introduced. Construction of a steel trawler and wooden trawler are shown in Fig. 4.2 and 4.3 respectively.



Fig. 4.2 Construction of a steel trawler



Fig. 4.3 Construction of a wooden trawler

4.3.1.1 Small trawlers

Trawlers less than 12 m L_{OA} are included in the small trawler category. These vessels are constructed using wood and are fitted with Indian made diesel engines with 76 to 98 hp. The total crew size is 3-4 persons. These vessels typically carry out single-day operations mostly confined to a depth zone of 10-50 m and fish hold is not provided. View of a small wooden trawler in Munambam harbour is shown in Fig. 4.4.



Fig. 4.4 View of a small wooden trawler

4.3.1.2 Medium trawlers

Trawlers ranging in L_{OA} from 12 to 16 m are classified as medium class trawlers. Steel and wood are used as the construction material in this class of trawlers and they are installed with diesel engines of 90 - 193 hp. These vessels undertake multi-day fishing operations. A fish hold made of FRP and insulated with polystyrene with a capacity of 10-15 m^3 is provided. These vessels have modern electronic equipments for navigation, communication and fish finding. The diesel tanks are provided in the aft and usually divided into 1-3 compartments. These vessels have a crew of 5-8. View of a medium sized trawler from Ernakulam is shown in Fig. 4.5.



Fig. 4.5 A medium sized trawler

4.3.1.3 Large trawlers

Size of large trawlers range from 16 to 24 m LOA. These vessels undertake multi-day fishing and are provided with a large fish hold with a capacity between 20-50 m³. The installed engine horse power ranges from 190 to 450 and one to two large diesel tanks with 6000-8000 litres capacity are provided. The vessels are provided with all the latest electronic equipment for navigation, communication and fish location and the crew complement is usually between 7 and 12. View of a large steel trawler in Ernakulam is shown in Fig. 4.6. Profile and deck layout of a large trawler is shown in Fig. 4.7.



Fig. 4.6 A large steel trawler

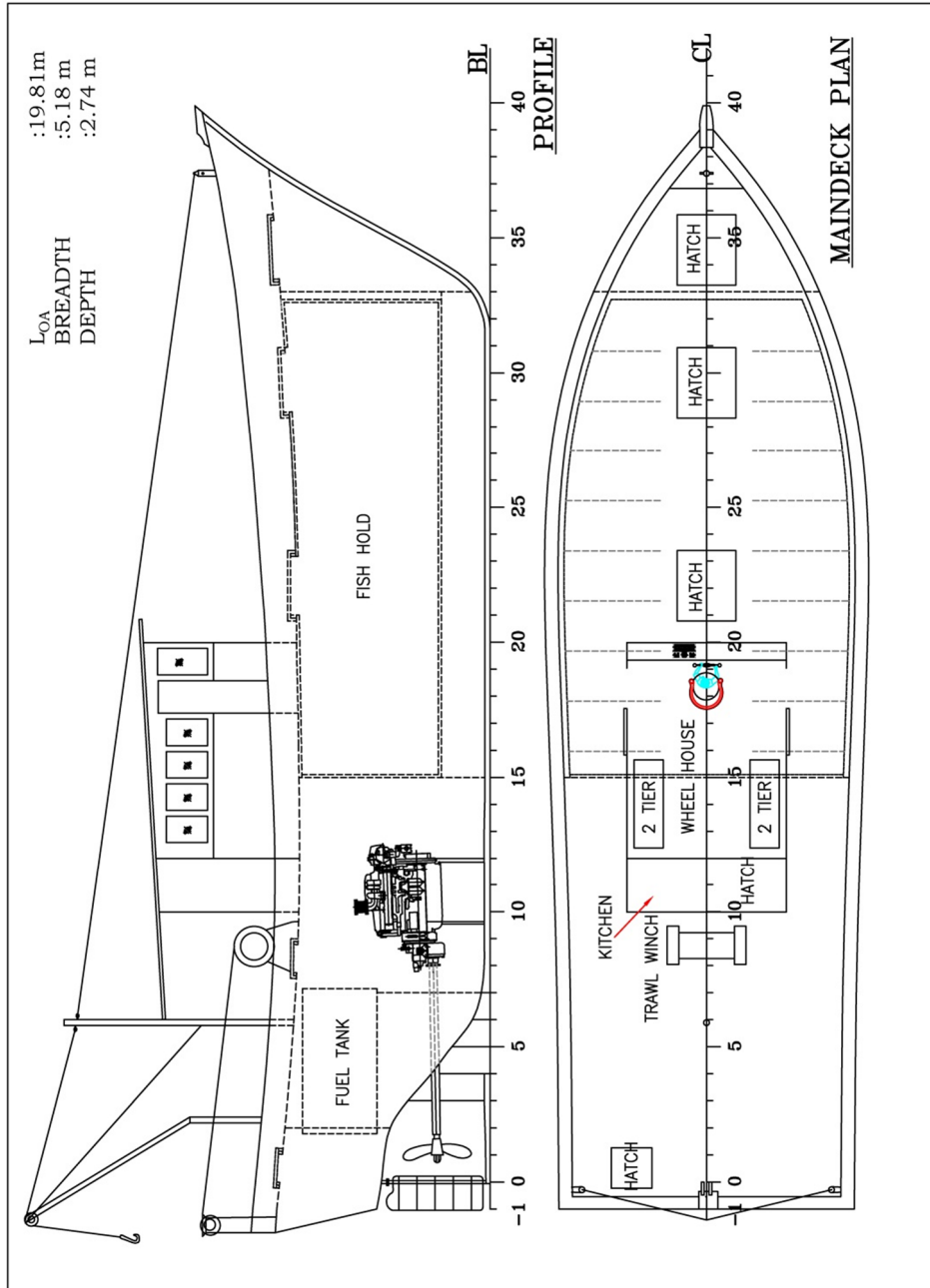

Fig. 4.7 Profile and deck layout of a large trawler

4.3.1.4 Very large trawlers

Vessels with L_{OA} more than 24 m are classified as very large trawlers. These vessels are well equipped for multi-day deep sea trawling. These vessels are mainly fitted with indigenous or imported, diesel engines with installed engine power above 450 hp. The fish hold capacity range between 30 and 50 m^3 . GPS, echo sounder and VHF transceiver are used for safe navigation and facilitate in fishing. Large diesel tanks with a total capacity between 6,000-8,000 litres are provided to facilitate long cruises and crew complement is 8-12. View of a very large steel trawler in Ernakulam is shown in Fig. 4.8. Profile and deck layout of a very large steel trawler is shown in Fig. 4.9.



Fig. 4.8 A very large steel trawler

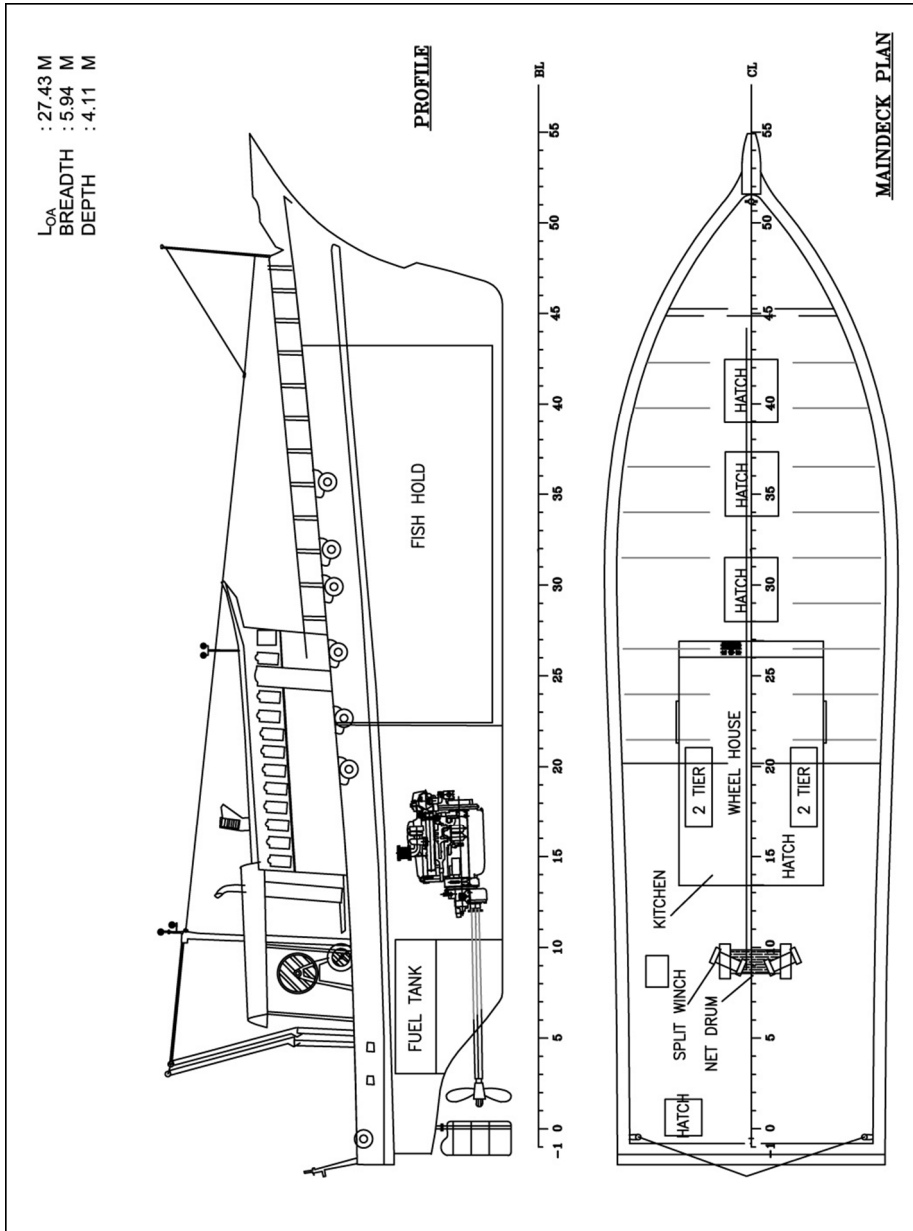

Fig. 4.9 Profile and deck layout of a very large trawler

4.3.2 Power and propulsion

The majority of the small sized vessels are using Indian made engines, but medium and large sized vessels are mostly installed with Chinese engines. The need for higher cruising speeds to reach the fishing ground and quicker transportation of fresh fish to the landing centres has resulted in a new trend of installing high horse power engines in the medium, large and very large sized fishing vessels. The imported engines with horse power ranging from 230 to 495 hp cater to power requirements of these vessels. The diesel consumption, which varied from 8 to 45 litre h⁻¹, depending on the size, installed engine horse power, displacement of the vessel, location of the fishing ground and duration of the fishing trip, contribute to the major share in the operational expenditure of the trawlers.

Propeller

Propellers are of two types: with three blades and with four blades mostly made of gun metal. The weight relationship of propeller with L_{OA} of trawlers is shown in Table 4.2. Three blade propeller used for trawlers is shown in Fig. 4.10.

Table 4.2: Propeller weight vs L_{OA} of trawlers

L _{OA} of trawlers (m)	Weight of propeller (kg)
09-12	35-85
12-16	60-95
16-24	95-200
> 24	160-220



Fig. 4.10 Three blade propellers used in trawlers

4.3.3 Trawl winch

Small trawlers use manually operated hand winches for hauling and shooting of net. Medium, large and very large trawlers mostly use mechanically driven winches with power take-off from the main engine and are positioned behind the wheel house. The power take-off ratio varied depending on the vessel. A few large trawlers have started the use of split winch. Hydraulic winch, is a recent entry and has been introduced in some medium sized trawlers. In addition to winches, recently, net drums have been introduced in very large trawlers for easy handling of trawl net (Fig. 4.11).



Fig. 4.11 Net drums used in a very large trawler in Kochi

4.3.4 Electronic navigation, fish finding and communication equipment

Most trawlers operating from Kerala are equipped with modern electronic navigation and fish finding equipment such as GPS, echo sounder and communication equipment such as VHF transceiver. Echo sounder is used for monitoring the depth of operation, nature of fishing ground and to detect the presence of fish. GPS is widely used for locating and marking the fishing ground for revisits. Most of the fishermen opined that use of GPS has significantly helped them in navigation and in fishing. Cellular phones are also used for communication in near shore waters.

4.3.5 Otterboards

Otterboards are rigid sheer devices which are used to keep the trawl mouth, bridles and warps horizontally open. Otterboards were first used in trawling in 1894, in Scottish waters (FAO, 1974). Otterboards contribute about 25% of the total drag of the trawl system and is responsible for about 16% of the total fuel consumption in trawling operations (Wileman, 1984; Seafish *et.al.*,1993).

Otterboard size is represented by length and height. The length of the otterboard is the horizontal distance between the forward and aft edges of the otterboard (Remesan, 2002). The height is measured perpendicular to the length. Otterboard spreading force or sheer force acts at right angles to the direction of towing and is used to spread the trawl mouth, warps and bridles, horizontally. Otterboard drag force acts in the direction opposite to the direction of towing.

Two types of otter boards are used in Kerala, *viz.*, wooden flat rectangular and V-form steel otter boards. Approximately 80% of trawlers use V-form steel otterboards as sheer devices. V-shaped otterboards are simple in design and are generally constructed in mild steel. However a small percentage of vessels less than 16 m L_{OA} use flat rectangular wooden otterboards. Almost all vessels have one or two sets of otterboards. The weight of otterboard ranges from 50 to 120 kg each, which is determined by the size of the trawl net and installed engine power. Design drawing of a typical V-form otterboard is shown in Fig. 4.12. The two types of otterboards used in Kerala are shown in Fig. 4.13 and 4.14.

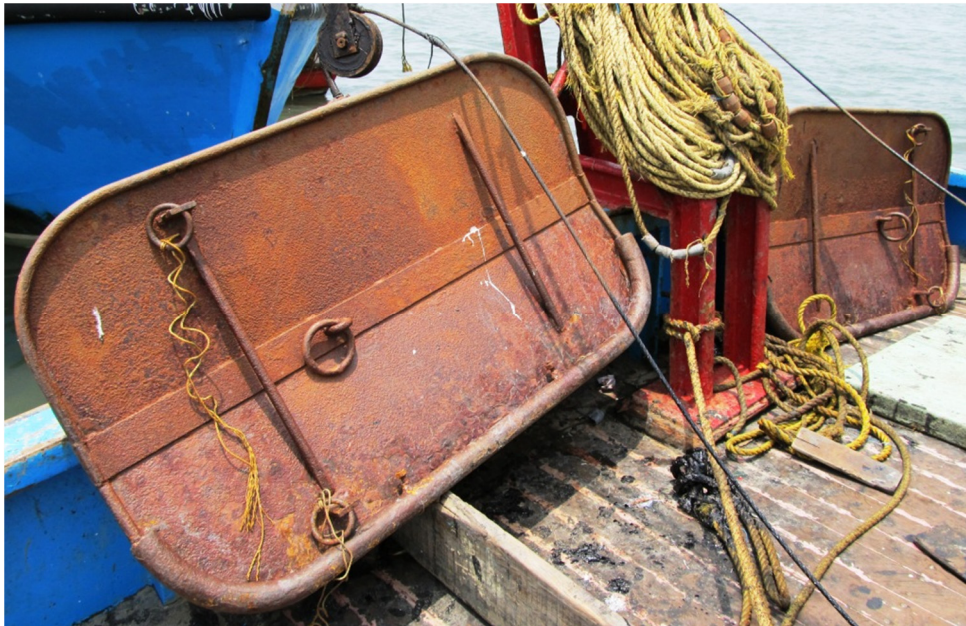

Fig 4.13 V-form steel otterboards onboard a trawler



Fig 4.14 Wooden flat rectangular otterboards

4.3.6 Life cycle inventory

The life cycle inventories of wooden and steel trawlers for their entire life cycles are shown in Table 4.3 and 4.4 respectively.

Table 4.3: Life cycle inventory of wooden trawlers (Fishing sub-system 1)

Inputs	Unit	10.66 m	13.71 m	15.3 m	18.9 m	19.81 m	21.33 m
Wood	kg	23396	30988	35421	44487	46340	51900
Plywood	kg	1445	1853	2073	2557	2670	2890
Engine	kg	2000	2000	2000	2000	2000	2250
Steel nail	kg	26	53	71	95	105	158
Propeller shaft	kg	70	70	70	76	76	80
Trawl winch	kg	500	500	600	750	750	750
SWR	kg	1200	1400	1600	1700	1800	1900
Propeller	kg	40	60	100	130	150	150
Copper nail	kg	53	158	242	420	525	683
Glass wool	kg	63	105	236	329	355	385
FRP	kg	525	682.5	761.25	945	1050	1050
Electricity	kWh	110	247.5	341	495	550	638
Primer	litre	150	195	228	285	300	309
Paint	litre	300	375	465	570	600	630
Antifouling paint	litre	180	210	240	300	300	300
Cotton	kg	110	176	231	308	330	550
Aluminium sheet	kg	330	440	605	770	825	1100
Wooden otterboard	kg	1800	1950	2100	-	-	-
Steel otterboard	kg	-	-	-	900	950	1000

Table 4.4: Life cycle inventory of steel trawlers (Fishing sub-system 1)

Inputs	Unit	13.71 m	15.3 m	18.9 m	19.81 m	21.33 m	22.86 m	24.38 m	25.9 m	27.43 m
Steel	kg	16500	19800	26400	27500	28600	29700	30800	33000	38500
Plywood	kg	1853	2073	2557	2723	2890	3110	3298	3518	3707
Engine	kg	2000	2000	2000	2000	2250	2500	2500	2500	2500
Propeller shaft	kg	70	70	76	76	80	80	100	130	130
Trawl winch	kg	500	600	750	750	750	750	750	1500	1500
SWR	kg	1400	1600	1700	1800	1900	2000	2100	2200	2300
Propeller	kg	100	120	150	150	150	160	180	200	220
Glass wool	kg	105	236	329	354	382	417	449	662	687
FRP	kg	525	761.25	1050	1050	1050	1050	1050	1155	1260
Welding rod	kg	1176	1207.5	1260	1365	1512	1680	1890	2205	2520
Wood	kg	7358	9289	11127	11127	11127	11127	11127	14523	12333
Electricity	kWh	1540	1705	1980	2024	2079	2145	2310	2695	3135
Primer	litre	250	290	350	360	370	380	410	430	450
Paint	litre	300	405	585	593	608	630	690	720	750
Antifouling paint	litre	210	240	300	300	300	300	300	360	360
Steel otterboard	kg	750	800	900	950	1000	1200	1200	1200	1200

4.3.7 Life cycle impact assessment

Under Life Cycle Assessment of trawlers, seven impact categories *viz.* Global warming potential (GWP), Abiotic depletion potential-fossil (ADP-fossil), Acidification potential (AP), Eutrophication potential (EP), Marine aquatic ecotoxicity potential (MAETP), Ozone depletion potential (ODP) and Photochemical ozone creation potential (POCP) were considered.

4.3.7.1 Global warming potential

Among the materials used for construction of 10.66 m small wooden single-day trawler, Global warming potential (GWP) was maximum for engine (30%) followed by aluminium sheet (20.8%), steel wire rope (18%), paints (10.8%), FRP (8.9%), trawl winch (7.5%), propeller shaft (1.1%), electricity (1%), glass wool (0.8%), copper (0.6%), steel nail (0.4%) and propeller (0.2%). GWP was negative in the case of wood used for construction (-2847 kg CO₂ Equiv.), wooden otterboard (-219 kg CO₂ Equiv.), marine plywood (-122.8 kg CO₂ Equiv.) and cotton (-5.4 kg CO₂ Equiv.) (Fig. 4.15).

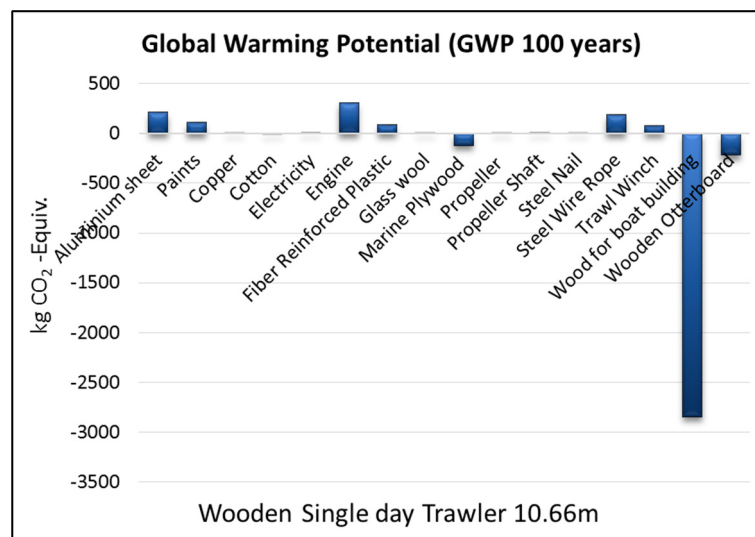

Fig. 4.15 Global warming potential of 10.66 m small wooden single-day trawler

Among the materials used for construction of 13.71 m medium wooden multi-day trawler, GWP was maximum for engine (25.3%) followed by aluminium sheet (23.3%), steel wire rope (17.7%), paints (11.4%), FRP (9.7%), trawl winch (6.3%), electricity (1.8%), copper (1.5%) glass wool (1.1%), propeller shaft (0.9%), steel nail (0.7%) and propeller (0.2%). GWP

was negative in the case of wood used for construction (-3770.9 kg CO₂ Equiv.), wooden otterboard (-237.3 kg CO₂ Equiv.), marine plywood (-157.5 kg CO₂ Equiv.) and cotton (-8.7 kg CO₂ Equiv.) (Fig. 4.16).

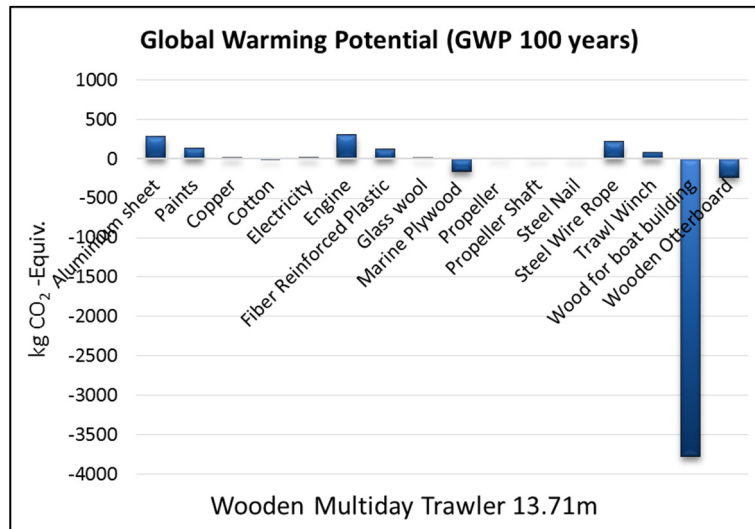

Fig. 4.16 Global warming potential of 13.71 m medium wooden multi-day trawler

Among the materials used for construction of 15.3 m medium wooden multi-day trawler, GWP was maximum for aluminium sheet (26.9%) followed by engine (21.2%), steel wire rope (17%), paints (11.5%), FRP (9.1%), trawl winch (6.4%), glass wool (2.2%), electricity (2.1%), copper (2.0%), steel nail (0.8%), propeller shaft (0.7%) and propeller (0.3%). GWP was negative in the case of wood used for construction (-4310.3 kg CO₂ Equiv.), wooden otterboard (-255.5 kg CO₂ Equiv.), marine plywood (-176.1 kg CO₂ Equiv.) and cotton (-11.4 kg CO₂ Equiv.) (Fig. 4.17).

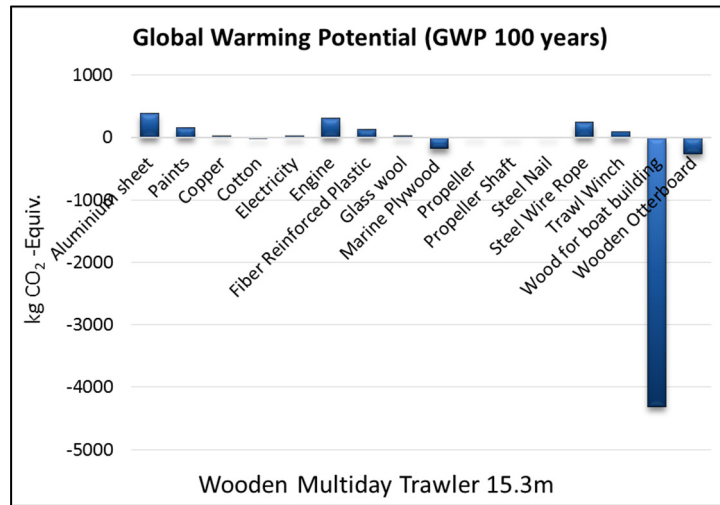

Fig. 4.17 Global warming potential of 15.3 m medium wooden multi-day trawler

Among the materials used for construction of 18.9 m large wooden multi-day trawler, GWP was maximum for aluminium sheet (26.7%) followed by engine (16.6%), steel wire rope (14.1%), paints (11%), FRP (8.8%), steel otterboard (7.5%), trawl winch (6.2%) copper (2.7%), electricity (2.4%), glass wool (2.4%), steel nail (0.8%), propeller shaft (0.6%) and propeller (0.3%). GWP was negative in the case of wood used for construction (-5413.5 kg CO₂ Equiv.), marine plywood (-217.2 kg CO₂ Equiv.) and cotton (-15.2 kg CO₂ Equiv.) (Fig. 4.18).

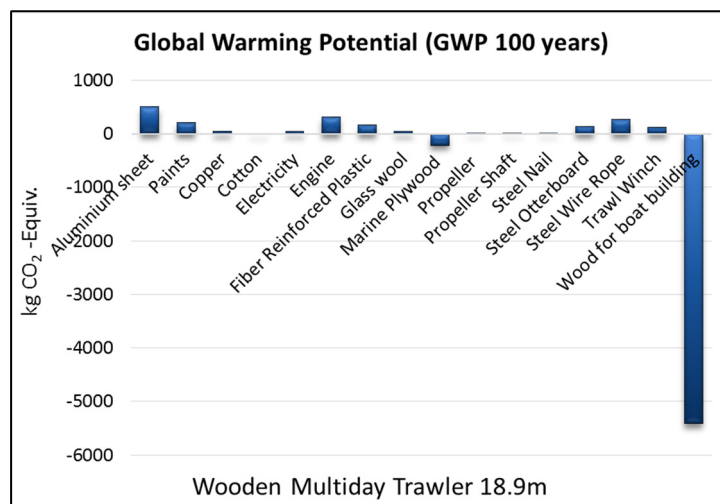

Fig. 4.18 Global warming potential of 18.9 m large wooden multi-day trawler

Among the materials used for construction of 19.81 m large wooden multi-day trawler, GWP was maximum for aluminium sheet (27.1%) followed by engine (15.7%), steel wire rope (14.1%), paints (10.9%), FRP (9.3%), steel otterboard (7.4%), trawl winch (5.9%) copper (3.1%), electricity (2.5%), glass wool (2.4%), steel nail (0.8%), propeller shaft (0.6%) and propeller (0.3%). GWP was negative in the case of wood used for construction (-5639 kg CO₂ Equiv.), marine plywood (-226.9 kg CO₂ Equiv.) and cotton (-16.3 kg CO₂ Equiv.) (Fig. 4.19).

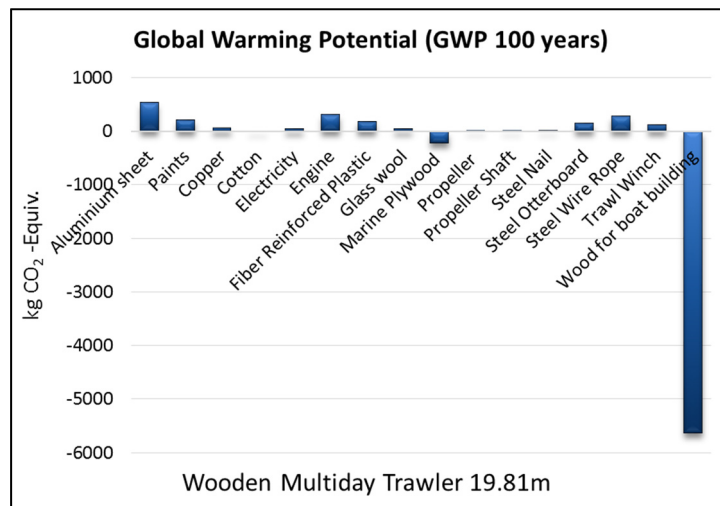

Fig. 4.19 Global warming potential of 19.81 m large wooden multi-day trawler

Among the materials used for construction of 21.33 m large wooden multi-day trawler, GWP was maximum for aluminium sheet (31.5%), followed by engine (15.4%), steel wire rope (13.0%), paints (9.7%), FRP (8.1%), steel otterboard (6.8%), trawl winch (5.1%), copper (3.6%), electricity (2.5%), glass wool (2.3%), steel nail (1.1%), propeller shaft (0.5%) and propeller (0.3%). GWP was negative in the case of wood used for construction (-6315.6 kg CO₂ Equiv.), marine plywood (-245.5 kg CO₂ Equiv.) and cotton (-27.2 kg CO₂ Equiv.) (Fig. 4.20).

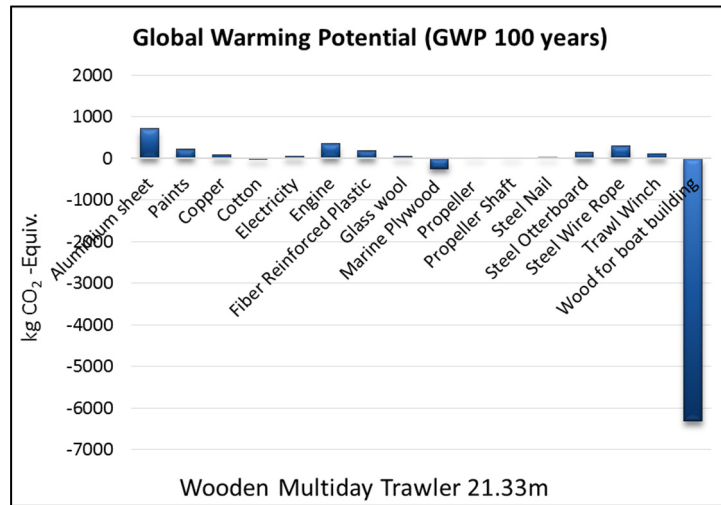

Fig. 4.20 Global warming potential of 21.33 m large wooden multi-day trawler

Among the materials used for construction of 13.71 m medium steel multi-day trawler, GWP was maximum for steel used for construction (65.8%) followed by engine (8%), steel wire rope (5.6%), electrode (5.4%), paints (3.7%), electricity (3.5%), FRP (2.4%), trawl winch (2.0%), glass wool (0.4%), propeller shaft (0.3%) and propeller (0.1%). GWP was negative in the case of wood used for construction (-895.4 kg CO₂ Equiv.) and marine plywood (-157.5 kg CO₂ Equiv.) (Fig. 4.21).

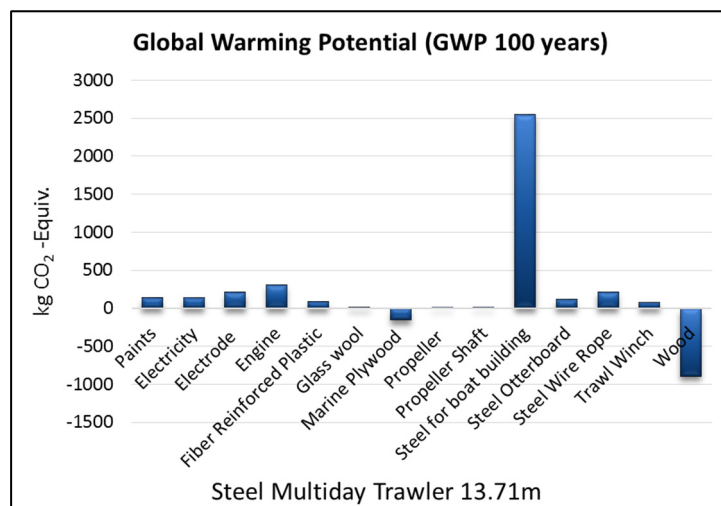

Fig. 4.21 Global warming potential of 13.71 m medium steel multi-day trawler

Among the materials used for construction of 15.3 m medium steel multi-day trawler, GWP was maximum for steel used for construction (67.2%) followed by engine (6.8%), steel wire rope (5.4%), electrode (4.8%), paints (3.7%), electricity (3.3%), FRP (2.4%), trawl winch (2.0%), glass wool (0.7%), propeller shaft (0.2%) and propeller (0.1%). GWP was negative in the case of wood used for construction (-1130.3 kg CO₂ Equiv.) and marine plywood (-176.1 kg CO₂ Equiv.) (Fig. 4.22).

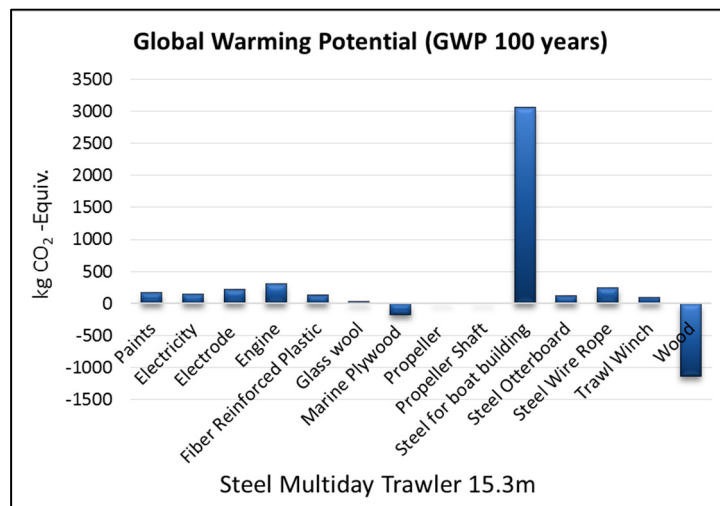

Fig. 4.22 Global warming potential of 15.3 m medium steel multi-day trawler

Among the materials used for construction of 18.9 m large steel multi-day trawler, GWP was maximum for steel used for construction (70.6%) followed by engine (5.3%), steel wire rope (4.5%), electrode (3.9%), paints (3.8%), FRP (3.2%), electricity (3.1%), steel otterboard (2.4%), trawl winch (2.0%), glass wool (0.8%), propeller shaft (0.2%) and propeller (0.1%). GWP was negative in the case of wood used for construction (-1454 kg CO₂ Equiv.) and marine plywood (-217.2 kg CO₂ Equiv.) (Fig. 4.23).

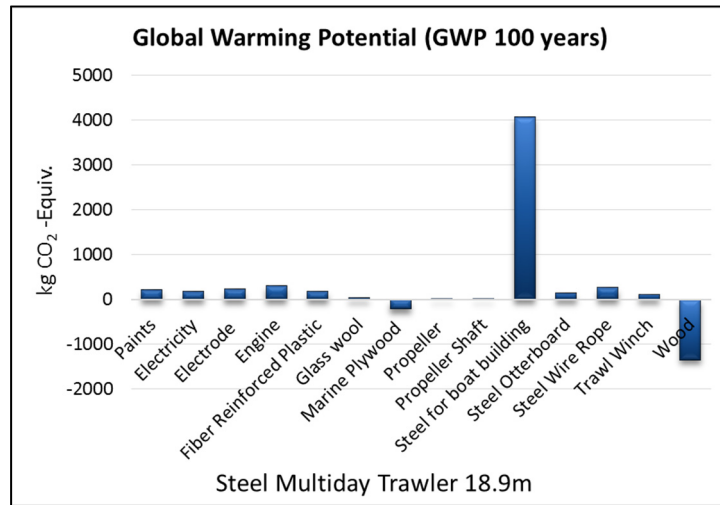

Fig. 4.23 Global warming potential of 18.9 m large steel multi-day trawler

Among the materials used for construction of 19.81 m large steel multi-day trawler, GWP was maximum for steel used for construction (70.8%) followed by engine (5.2%), steel wire rope (4.6%), electrode (4.1%), paints (3.8%), FRP (3.1%), electricity (3.0%), steel otterboard (2.4%), trawl winch (1.9%), glass wool (0.8%), propeller shaft (0.2%) and propeller (0.1%). GWP was negative in the case of wood used for construction (-1354 kg CO₂ Equiv.) and marine plywood (-231.3 kg CO₂ Equiv.) (Fig. 4.24).

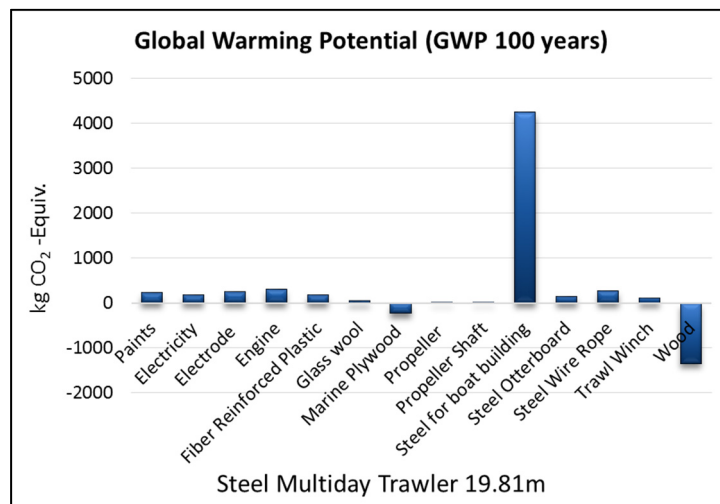

Fig. 4.24 Global warming potential of 19.81 m large steel multi-day trawler

Among the materials used for construction of 21.33 m large steel multi-day trawler, GWP was maximum for steel used for construction (70.5%) followed by engine (5.5%), steel wire rope (4.7%), electrode (4.3%), paints (3.7%), electricity (3.0%), FRP (2.9%), steel otterboard (2.5%), trawl winch (1.8%), glass wool (0.8%), propeller shaft (0.2%) and propeller (0.1%). GWP was negative in the case of wood used for construction (-1354kg CO₂ Equiv.) and marine plywood (-245.5 kg CO₂ Equiv.) (Fig. 4.25).

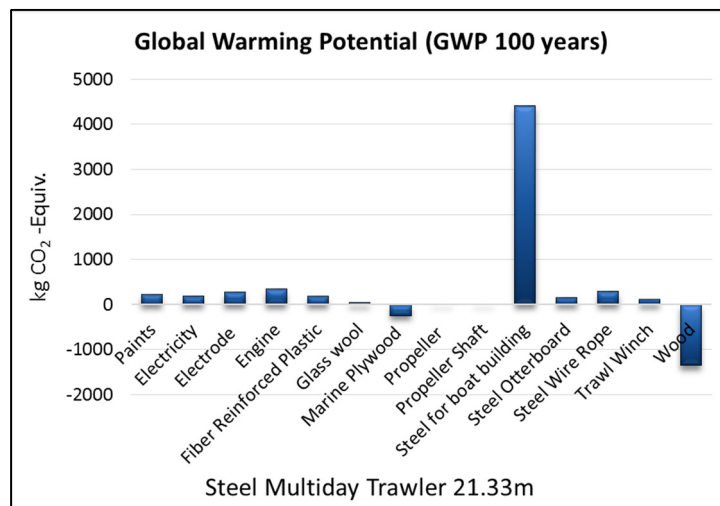

Fig. 4.25 Global warming potential of 21.33 m large steel multi-day trawler

Among the materials used for construction of 22.86 m large steel multi-day trawler, GWP was maximum for steel used for construction (69.8%) followed by engine (5.9%), steel wire rope (4.7%), electrode (4.6%), paints (3.5%), electricity (2.9%), FRP (2.8%), steel otterboard (2.8%), trawl winch (1.8%), glass wool (0.8%), propeller shaft (0.2%) and propeller (0.1%). GWP was negative in the case of wood used for construction (-1354 kg CO₂ Equiv.) and marine plywood (-264.2 kg CO₂ Equiv.) (Fig. 4.26).

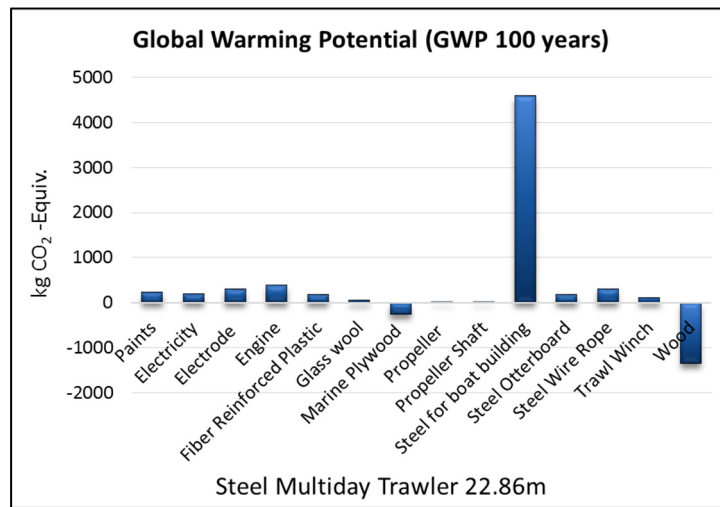

Fig. 4.26 Global warming potential of 22.86 m large steel multi-day trawler

Among the materials used for construction of 24.38 m very large steel multi-day trawler, GWP was maximum for steel used for construction (69.6%) followed by engine (5.7%), electrode (5%), steel wire rope (4.7%), paints (3.7%), electricity (3%), FRP (2.7%), steel otterboard (2.7%), trawl winch (1.7%), glass wool (0.9%), propeller shaft (0.2%) and propeller (0.1%). GWP was negative in the case of wood used for construction (-1354 kg CO₂ Equiv.) and marine plywood (-280.2 kg CO₂ Equiv.) (Fig. 4.27).

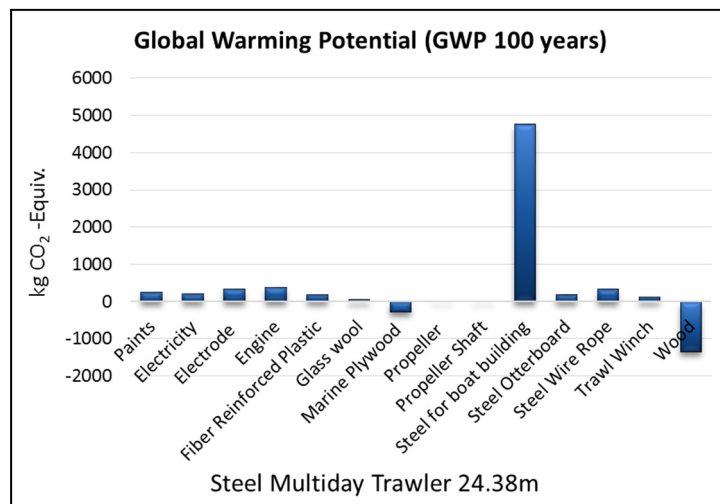

Fig. 4.27 Global warming potential of 24.38 m very large steel multi-day trawler

Among the materials used for construction of 25.9 m very large steel multi-day trawler, GWP was maximum for steel used for construction (68.3%) followed by electrode (5.3%), engine (5.2%), steel wire rope (4.6%), paints (3.7%), electricity (3.2%), trawl winch (3.1%), FRP (2.7%), steel otterboard (2.5%), glass wool (1.2%), propeller shaft (0.3%) and propeller (0.1%). GWP was negative in the case of wood used for construction (-1767.3 kg CO₂ Equiv.) and marine plywood (-298.9 kg CO₂ Equiv.) (Fig. 4.28).

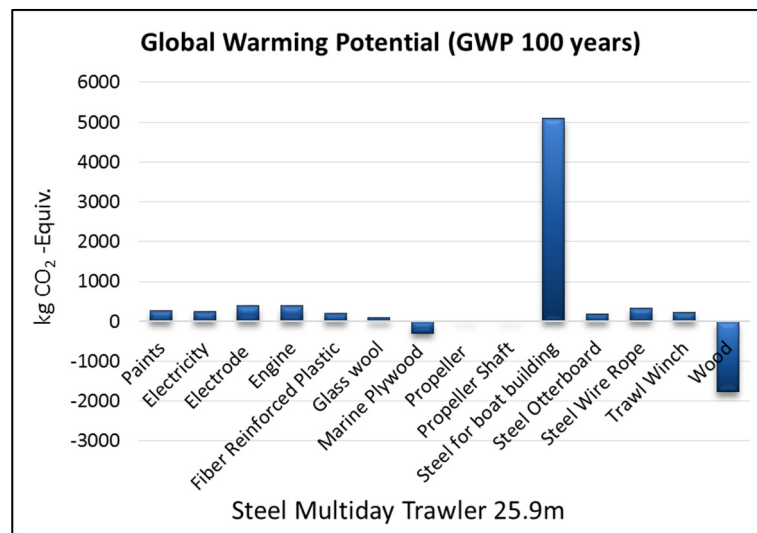

Fig. 4.28 Global warming potential of 25.9 m very large steel multi-day trawler

Among the materials used for construction of 27.43 m very large steel multi-day trawler, GWP was maximum for steel used for construction (70.3%) followed by electrode (5.3%), engine (4.6%), steel wire rope (4.2%), paints (3.3%), electricity (3.3%), trawl winch (2.7%), FRP (2.6%), steel otterboard (2.2%), glass wool (1.1%), propeller shaft (0.2%) and propeller (0.1%). GWP was negative in the case of wood used for construction (-1500.8 kg CO₂ Equiv.) and marine plywood (-315 kg CO₂ Equiv.) (Fig. 4.29).

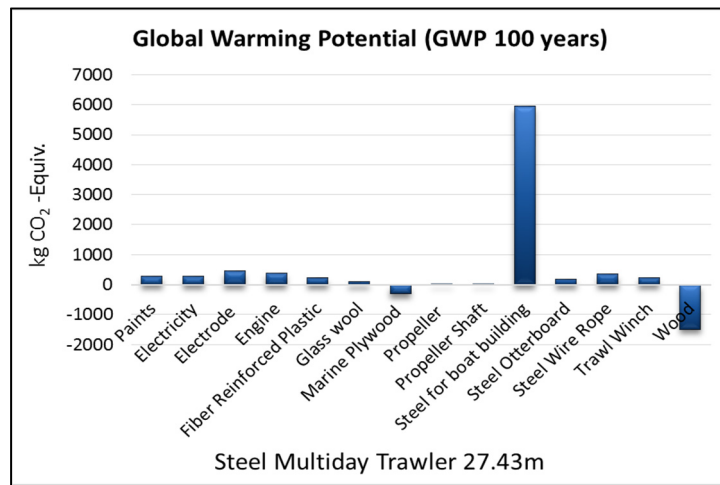

Fig. 4.29 Global warming potential of 27.43 m very large steel multi-day trawler

4.3.7.2 Abiotic depletion potential (fossil)

Among the materials used for construction of 10.66 m small wooden single-day trawler, Abiotic depletion potential (fossil) (ADP-fossil) was maximum for engine (22.1%) followed by paints (18%), aluminium sheet (16.4%), FRP (13.7%), steel wire rope (13.3%), trawl winch (5.5%), wood used for construction (3.6%), marine plywood (3.5%), glass wool (0.9%), propeller shaft (0.8%), electricity (0.7%), cotton (0.5%), steel nail (0.3%), copper (0.3%), wooden otterboard (0.3%) and propeller (0.1%) (Fig. 4.30).

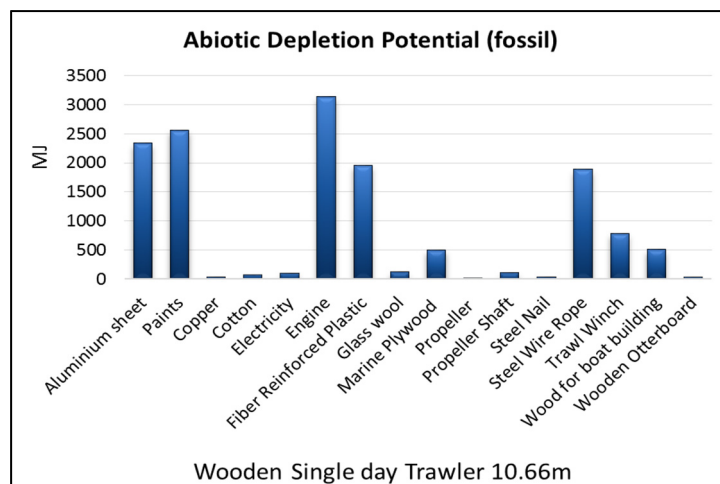

Fig. 4.30 Abiotic depletion potential of 10.66 m small wooden single-day trawler

Among the materials used for construction of 13.71 m medium wooden multi-day trawler, ADP-fossil was maximum for paints (18.4%) followed by engine (18.2%), aluminium sheet (18.1%), FRP (14.8%), steel wire rope (12.8%), trawl winch (4.6%), wood used for construction (3.9%), marine plywood (3.7%), electricity (1.3%), glass wool (1.2%), cotton (0.7%), copper (0.7%), propeller shaft (0.6%), steel nail (0.5%), wooden otterboard (0.2%) and propeller (0.2%) (Fig. 4.31).

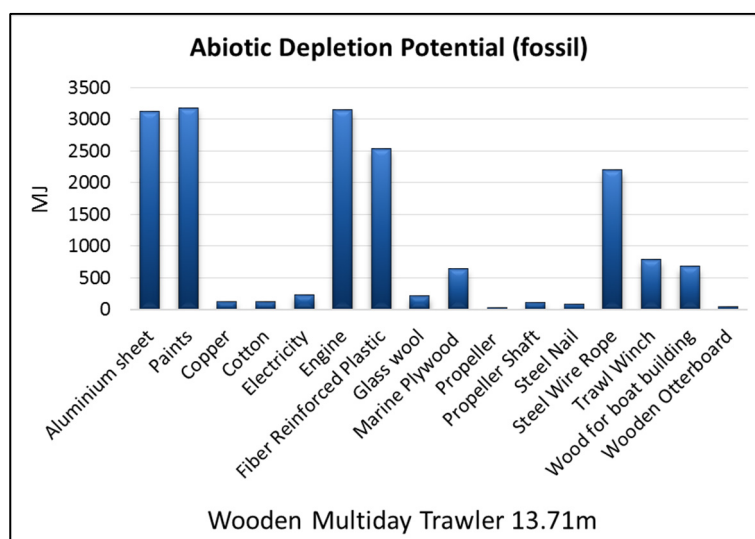

Fig. 4.31 Abiotic depletion potential of 13.71 m medium wooden multi-day trawler

Among the materials used for construction of 15.3 m medium wooden multi-day trawler, ADP-fossil was maximum for aluminium sheet (21%) followed by paints (18.5%), engine (15.4%), FRP (13.9%), steel wire rope (12.3%), trawl winch (4.6%), wood used for construction (3.8%), marine plywood (3.5%), glass wool (2.3%), electricity (1.5%), copper (0.9%), cotton (0.7%), propeller shaft (0.5%), steel nail (0.5%), wooden otterboard (0.2%) and propeller (0.2%) (Fig. 4.32).

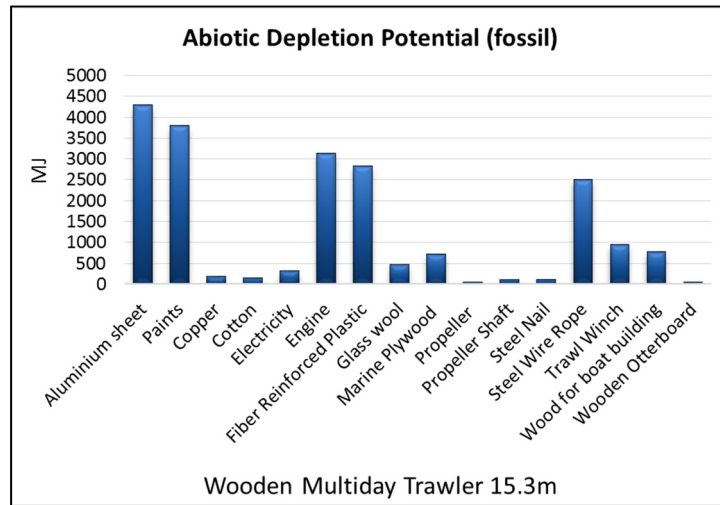

Fig. 4.32 Abiotic depletion potential of 15.3 m medium wooden multi-day trawler

Among the materials used for construction of 18.9 m large wooden multi-day trawler, ADP-fossil was maximum for aluminium sheet (21.1%) followed by paints (18.1%), FRP (13.6%), engine (12.1%), steel wire rope (10.3%), steel otterboard (5.5%), trawl winch (4.5%), wood used for construction (3.7%), marine plywood (3.4%), glass wool (2.5%), electricity (1.8%), copper (1.2%), cotton (0.8%), steel nail (0.6%), propeller shaft (0.5%) and propeller (0.2%) (Fig. 4.33).

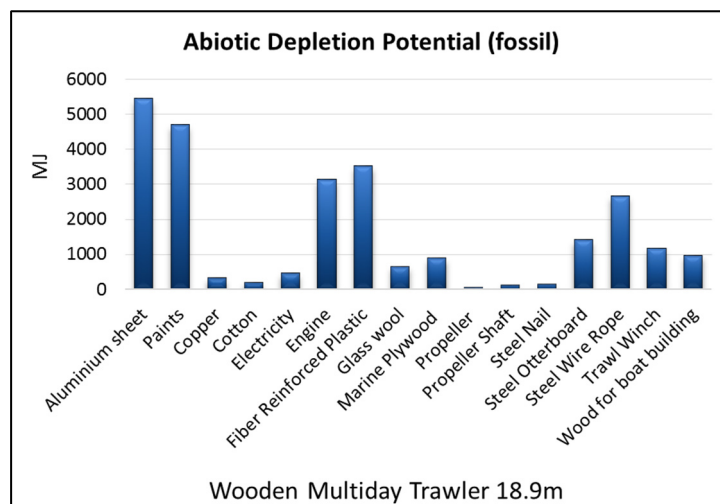

Fig. 4.33 Abiotic depletion potential of 18.9 m large wooden multi-day trawler

Among the materials used for construction of 19.81 m large wooden multi-day trawler, ADP-fossil was maximum for aluminium sheet (21.3%) followed by paints (17.8%), FRP (14.3%), engine (11.5%), steel wire rope (10.3%), steel otterboard (5.4%), trawl winch (4.3%), wood used for construction (3.7%), marine plywood (3.4%), glass wool (2.6%), electricity (1.9%), copper (1.5%), cotton (0.8%), steel nail (0.6%), propeller shaft (0.4%) and propeller (0.3%) (Fig. 4.34).

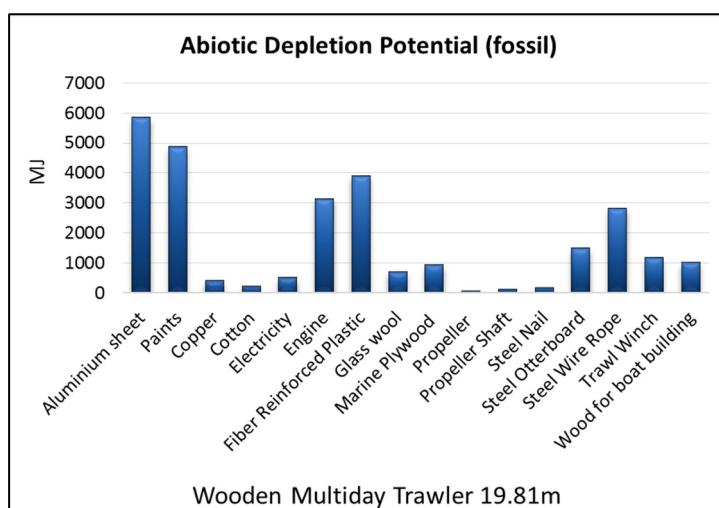

Fig. 4.34 Abiotic depletion potential of 19.81 m large wooden multi-day trawler

Among the materials used for construction of 21.33 m large wooden multi-day trawler, ADP-fossil was maximum for aluminium sheet (25.3%) followed by paints (16.4%), FRP (12.7%), engine (11.5%), steel wire rope (9.7%), steel otterboard (5.1%), trawl winch (3.8%), wood used for construction (3.7%), marine plywood (3.3%), glass wool (2.5%), electricity (1.9%), copper (1.7%), cotton (1.2%), steel nail (0.8%), propeller shaft (0.4%) and propeller (0.2%) (Fig. 4.35).

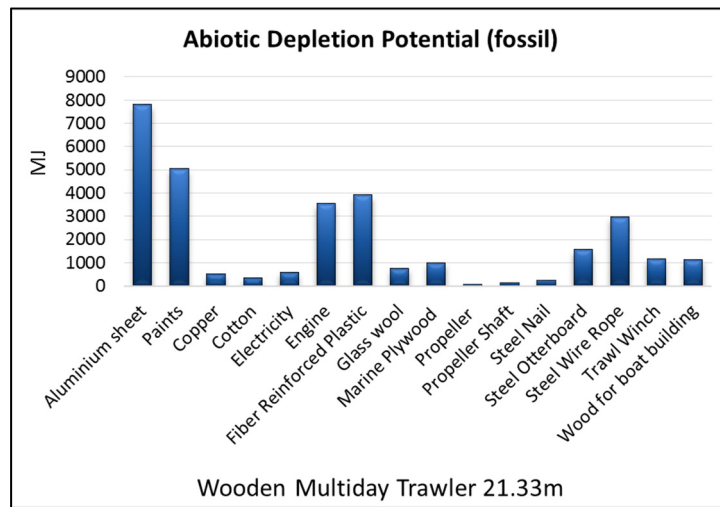

Fig. 4.35 Abiotic depletion potential of 21.33 m large wooden multi-day trawler

Among the materials used for construction of 13.71 m medium steel multi-day trawler, ADP-fossil was maximum for steel used for construction (57.1%) followed by electrode (9.8%), paints (7%), engine (6.9%), steel wire rope (4.8%), FRP (4.3%), electricity (3.2%), steel otterboard (2.6%), trawl winch (1.7%), marine plywood (1.4%), glass wool (0.5%), wood used for construction (0.4%), propeller shaft (0.2%) and propeller (0.1%) (Fig. 4.36).

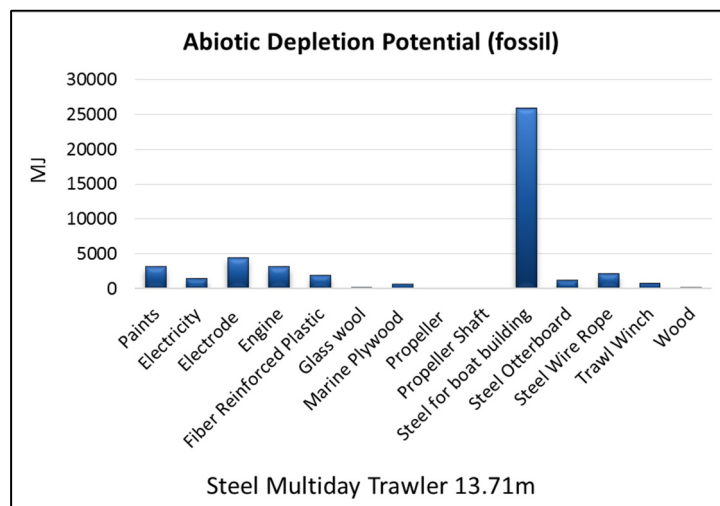

Fig. 4.36 Abiotic depletion potential of 13.71 m medium steel multi-day trawler

Among the materials used for construction of 15.3 m medium steel multi-day trawler, ADP-fossil was maximum for steel used for construction (58.3%) followed by electrode (8.5%), paints (7.1%), engine (5.9%), FRP (5.3%), steel wire rope (4.7%), electricity (3.0%), steel otterboard (2.4%), trawl winch (1.8%), marine plywood (1.4%), glass wool (0.9%), wood used for construction (0.4%), propeller shaft (0.2%) and propeller (0.1%) (Fig. 4.37).

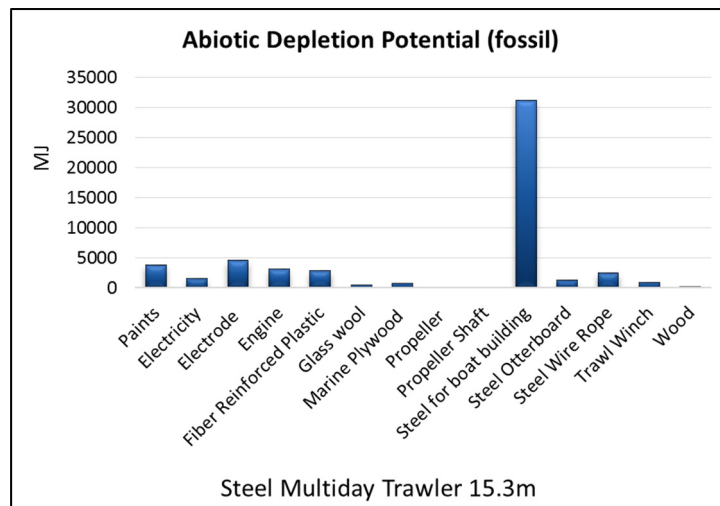

Fig. 4.37 Abiotic depletion potential of 15.3 m medium steel multi-day trawler

Among the materials used for construction of 18.9 m large steel multi-day trawler, ADP-fossil was maximum for steel used for construction (61.5%) followed by paints (7.5%), electrode (7.1%), FRP (5.8%), engine (4.7%), steel wire rope (4.0%), electricity (2.7%), steel otterboard (2.1%), trawl winch (1.7%), marine plywood (1.3%), glass wool (1.0%), wood used for construction (0.4%), propeller shaft (0.2%) and propeller (0.1%) (Fig. 4.38).

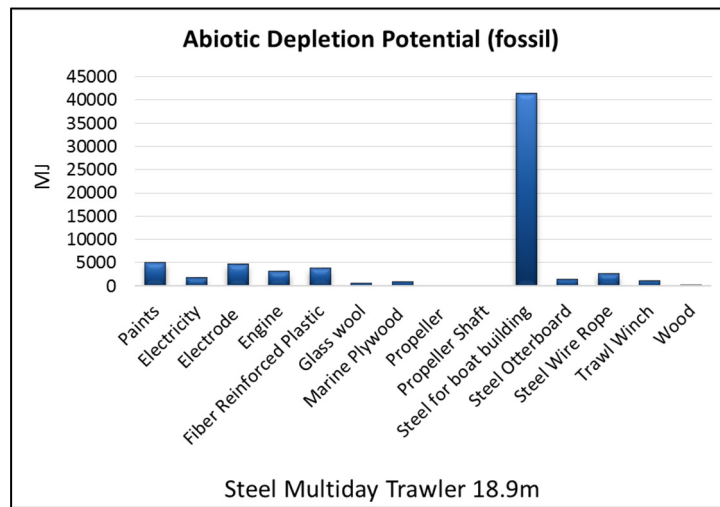

Fig. 4.38 Abiotic depletion potential of 18.9 m large steel multi-day trawler

Among the materials used for construction of 19.81 m large steel multi-day trawler, ADP-fossil was maximum for steel used for construction (61.7%) followed by paints (7.4%), electrode (7.4%), FRP (5.6%), engine (4.5%), steel wire rope (4.0%), electricity (2.7%), steel otterboard (2.1%), trawl winch (1.7%), marine plywood (1.4%), glass wool (1.0%), wood used for construction (0.3%), propeller shaft (0.2%) and propeller (0.1%) (Fig. 4.39).

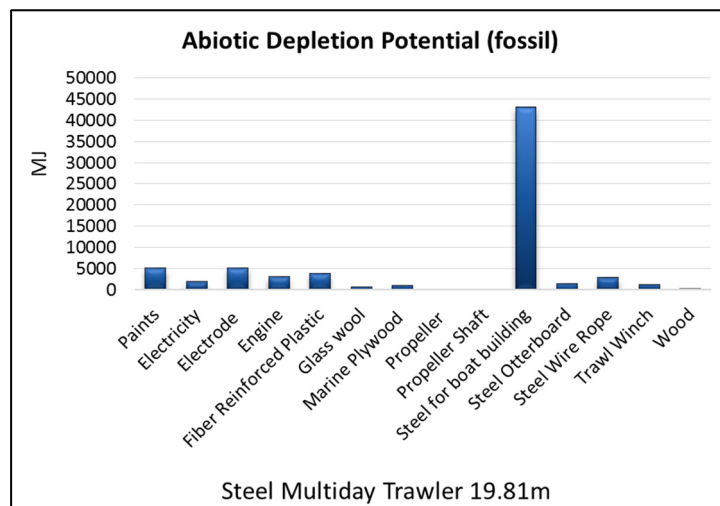

Fig. 4.39 Abiotic depletion potential of 19.81 m large steel multi-day trawler

Among the materials used for construction of 21.33 m large steel multi-day trawler, ADP-fossil was maximum for steel used for construction (61.4%) followed by electrode (7.8%), paints (7.2%), FRP (5.3%), engine (4.8%), steel wire rope (4.1%), electricity (2.6%), steel otterboard (2.1%), trawl winch (1.6%), marine plywood (1.4%), glass wool (1.0%), wood used for construction (0.3%), propeller shaft (0.2%) and propeller (0.1%) (Fig. 4.40).

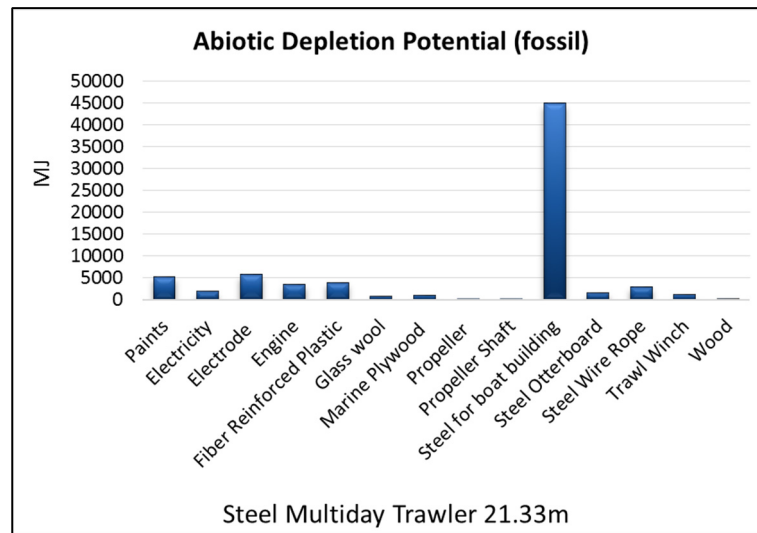

Fig. 4.40 Abiotic depletion potential of 21.33 m large steel multi-day trawler

Among the materials used for construction of 22.86 m large steel multi-day trawler, ADP-fossil was maximum for steel used for construction (60.8%) followed by electrode (8.3%), paints (7.0%), FRP (5.1%), engine (5.1%), steel wire rope (4.1%), electricity (2.6%), steel otterboard (2.5%), trawl winch (1.5%), marine plywood (1.4%), glass wool (1.1%), wood used for construction (0.3%), propeller shaft (0.2%) and propeller (0.1%) (Fig. 4.41).

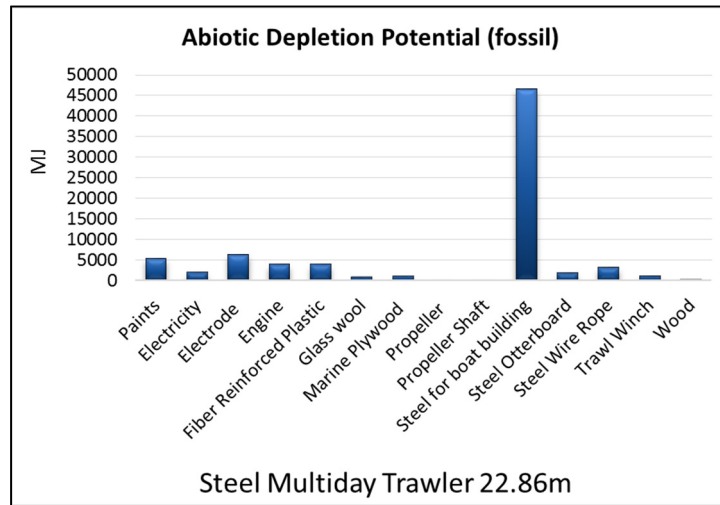

Fig. 4.41 Abiotic depletion potential of 22.86 m large steel multi-day trawler

Among the materials used for construction of 24.38 m very large steel multi-day trawler, ADP-fossil was maximum for steel used for construction (60.4%) followed by electrode (8.9%), paints (7.1%), FRP (4.9%), engine (4.9%), steel wire rope (4.1%), electricity (2.7%), steel otterboard (2.4%), trawl winch (1.5%), marine plywood (1.4%), glass wool (1.1%), wood used for construction (0.3%), propeller shaft (0.2%) and propeller (0.1%) (Fig. 4.42).

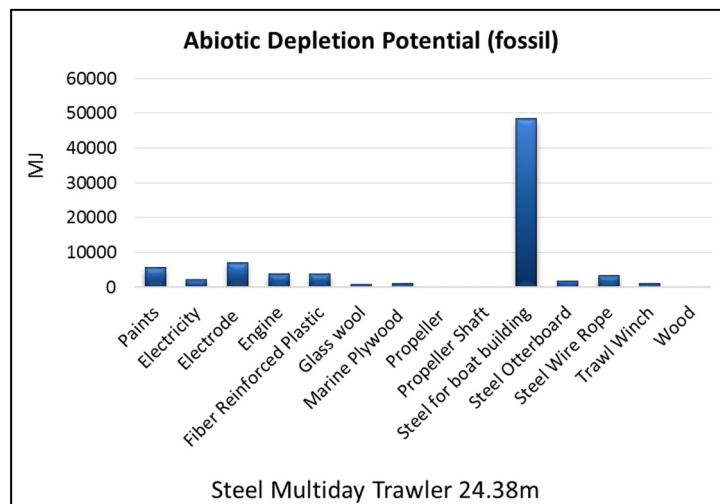

Fig. 4.42 Abiotic depletion potential of 24.38 m very large steel multi-day trawler

Among the materials used for construction of 25.9 m very large steel multi-day trawler, ADP-fossil was maximum for steel used for construction (59.0%) followed by electrode (9.5%), paints (7.1%), FRP (4.9%), engine (4.5%), steel wire rope (3.9%), electricity (2.8%), trawl winch (2.7%), steel otterboard (2.1%), glass wool (1.5%), marine plywood (1.4%), wood used for construction (0.4%), propeller shaft (0.2%) and propeller (0.1%) (Fig. 4.43).

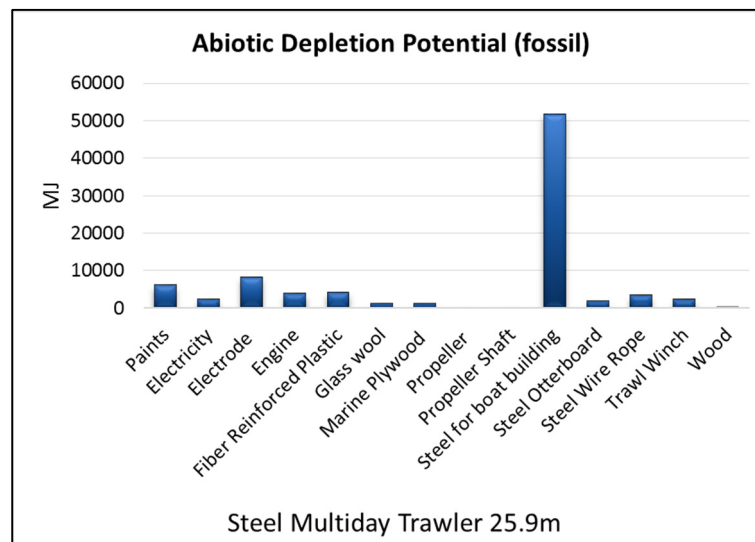

Fig. 4.43 Abiotic depletion potential of 25.9 m very large steel multi-day trawler

Among the materials used for construction of 27.43 m very large steel multi-day trawler, ADP-fossil was maximum for steel used for construction (61.1%) followed by electrode (9.6%), paints (6.4%), FRP (4.7%), engine (4.0%), steel wire rope (3.6%), electricity (2.9%), trawl winch (2.4%), steel otterboard (1.9%), glass wool (1.4%), marine plywood (1.3%), wood used for construction (0.3%), propeller shaft (0.2%) and propeller (0.1%) (Fig. 4.44).

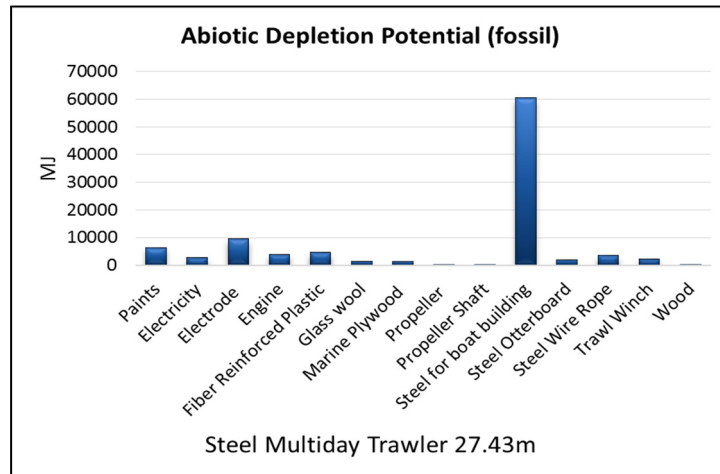

Fig. 4.44 Abiotic depletion potential of 27.43 m very large steel multi-day trawler

4.3.7.3 Acidification potential

Among the materials used for construction of 10.66 m small wooden single-day trawler, Acidification potential (AP) was maximum for engine (24.4%) followed by paints (21.5%), aluminium sheet (16.3%), steel wire rope (14.6%), trawl winch (6.1%), FRP (4.7%), marine plywood (3.9%), wood used for construction (2.1%), electricity (1.8%), copper (1.2%), propeller shaft (0.9%), cotton (0.9%), glass wool (0.8%), propeller (0.4%), steel nail (0.3%) and wooden otterboard (0.2%) (Fig. 4.45).

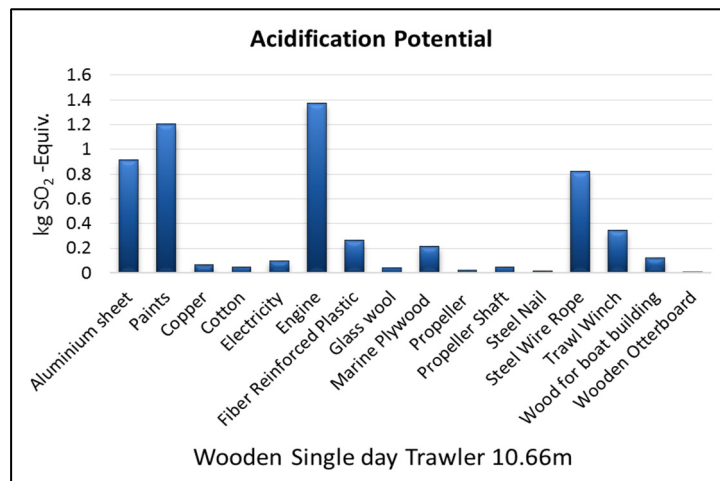

Fig. 4.45 Acidification potential of 10.66 m small wooden single-day trawler

Among the materials used for construction of 13.71 m medium wooden multi-day trawler, AP was maximum for paints (21.8%) followed by engine (20%), aluminium sheet (17.7%), steel wire rope (14%), trawl winch (5%), FRP (5%), marine plywood (4.1%), electricity (3.2%), copper (2.9%), wood used for construction (2.3%), cotton (1.1%), glass wool (1.1%), propeller shaft (0.7%), steel nail (0.5%), propeller (0.5%) and wooden otterboard (0.1%) (Fig. 4.46).

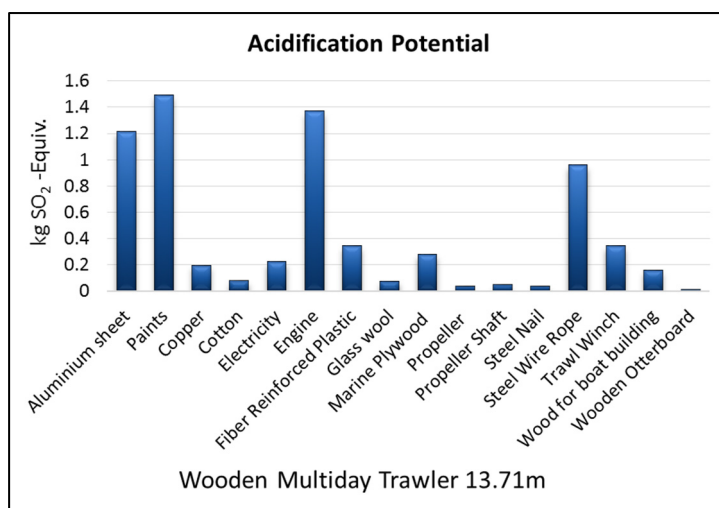

Fig. 4.46 Acidification potential of 13.71 m medium wooden multi-day trawler

Among the materials used for construction of 15.3 m medium wooden multi-day trawler, AP was maximum for paints (21.7%) followed by aluminium sheet (20.3%), engine (16.6%), steel wire rope (13.3%), trawl winch (5%), FRP (4.6%), marine plywood (3.8%), electricity (3.7%), copper (3.6%), wood used for construction (2.2%), glass wool (2%), cotton (1.2%), propeller (0.7%), propeller shaft (0.6%), steel nail (0.6%) and wooden otterboard (0.1%) (Fig. 4.47).

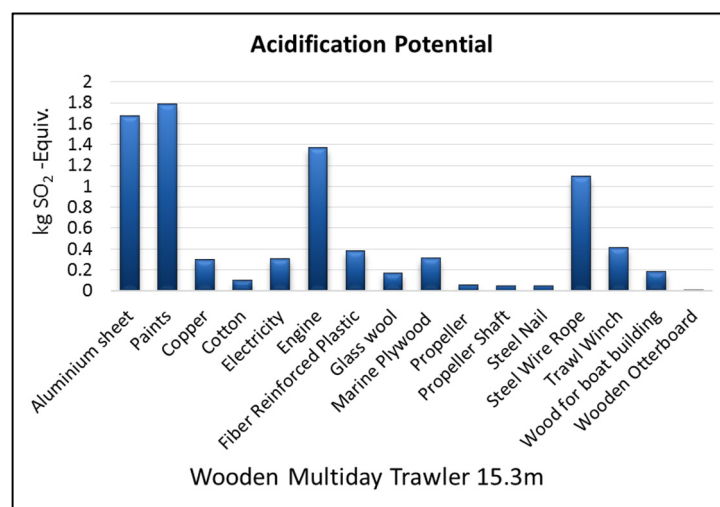

Fig. 4.47 Acidification potential of 15.3 m medium wooden multi-day trawler

Among the materials used for construction of 18.9 m large wooden multi-day trawler, AP was maximum for paints (20.8%) followed by aluminium sheet (20%), engine (12.9%), steel wire rope (11%), steel otterboard (5.8%), copper (4.9%), trawl winch (4.8%), FRP (4.5%), electricity (4.2%), marine plywood (3.6%), wood used for construction (2.2%), glass wool (2.2%), cotton (1.3%), propeller (0.7%), steel nail (0.6%) and propeller shaft (0.5%) (Fig. 4.48).

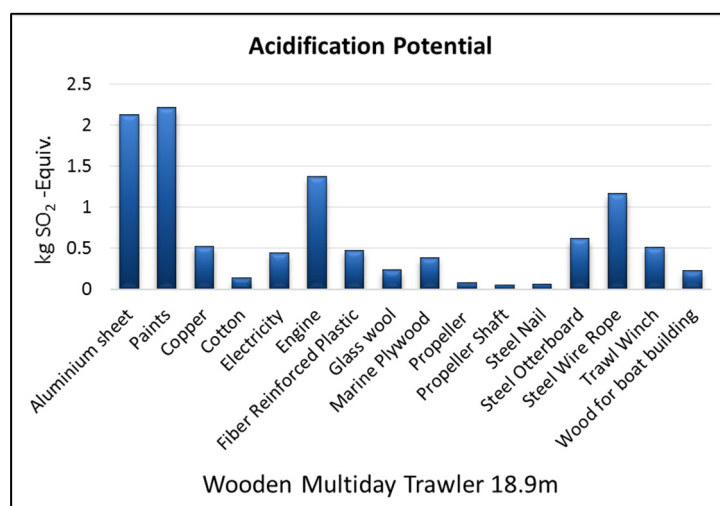

Fig. 4.48 Acidification potential of 18.9 m large wooden multi-day trawler

Among the materials used for construction of 19.81 m large wooden multi-day trawler, AP was maximum for paints (20.4%) followed by aluminium sheet (20.2%), engine (12.1%), steel wire rope (10.9%), steel otterboard (5.8%), copper (5.8%), FRP (4.7%), trawl winch (4.6%), electricity (4.4%), marine plywood (3.6%), glass wool (2.2%), wood used for construction (2.1%), cotton (1.3%), propeller (0.8%), steel nail (0.6%) and propeller shaft (0.5%) (Fig. 4.49).

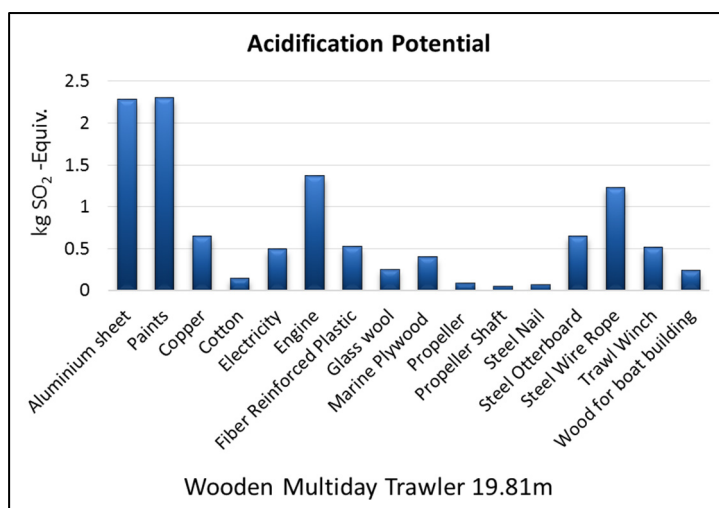

Fig. 4.49 Acidification potential of 19.81 m large wooden multi-day trawler

Among the materials used for construction of 21.33 m large wooden multi-day trawler, AP was maximum for aluminium sheet (23.6%) followed by paints (18.4%), engine (12%), steel wire rope (10.1%), copper (6.6%), steel otterboard (5.3%), electricity (4.5%), FRP (4.1%), trawl winch (4%), marine plywood (3.4%), glass wool (2.1%), wood used for construction (2.1%), cotton (1.9%), propeller (0.7%), steel nail (0.8%) and propeller shaft (0.4%) (Fig. 4.50).

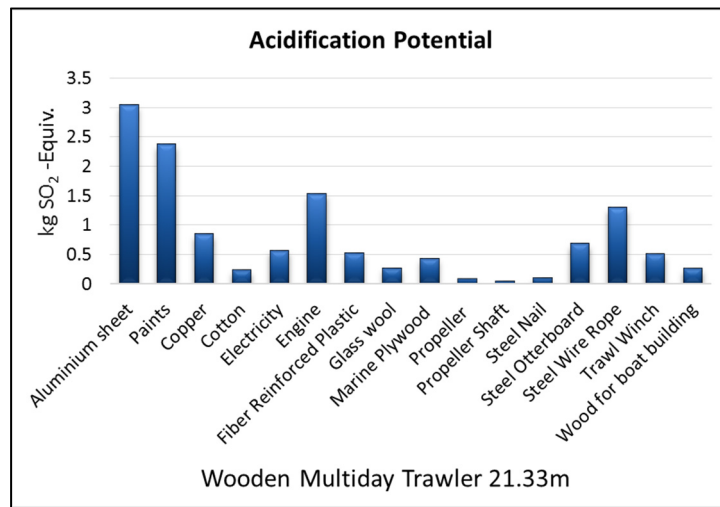

Fig. 4.50 Acidification potential of 21.33 m large wooden multi-day trawler

Among the materials used for construction of 13.71 m medium steel multi-day trawler, AP was maximum for steel used for construction (56.9%) followed by electrode (8.9%), paints (7.3%), electricity (7%), engine (6.9%), steel wire rope (4.8%), steel otterboard (2.6%), trawl winch (1.7%), marine plywood (1.4%), FRP (1.3%), glass wool (0.4%), propeller (0.3%), wood used for construction (0.2%) and propeller shaft (0.2%) (Fig. 4.51).

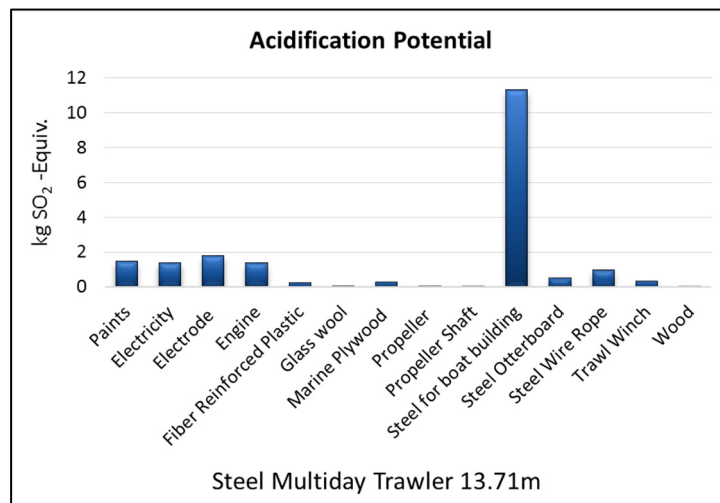

Fig. 4.51 Acidification potential of 13.71 m medium steel multi-day trawler

Among the materials used for construction of 15.3 m medium steel multi-day trawler, AP was maximum for steel used for construction (58.5%) followed by electrode (7.9%), paints (7.8%), electricity (6.6%), engine (5.9%), steel wire rope (4.7%), steel otterboard (2.4%), trawl winch (1.8%), FRP (1.6%), marine plywood (1.3%), glass wool (0.7%), propeller (0.3%), wood used for construction (0.2%) and propeller shaft (0.2%) (Fig. 4.52).

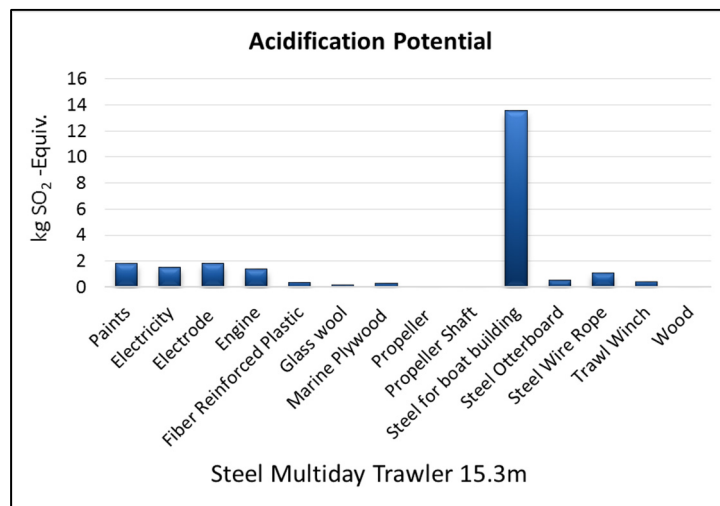

Fig. 4.52 Acidification potential of 15.3 m medium steel multi-day trawler

Among the materials used for construction of 18.9 m large steel multi-day trawler, AP was maximum for steel used for construction (62.0%) followed by paints (8.1%), electrode (6.5%), electricity (6.1%), engine (4.7%), steel wire rope (4.0%), steel otterboard (2.1%), trawl winch (1.8%), FRP (1.8%), marine plywood (1.3%), glass wool (0.8%), propeller (0.3%), wood used for construction (0.2%) and propeller shaft (0.2%) (Fig. 4.53).

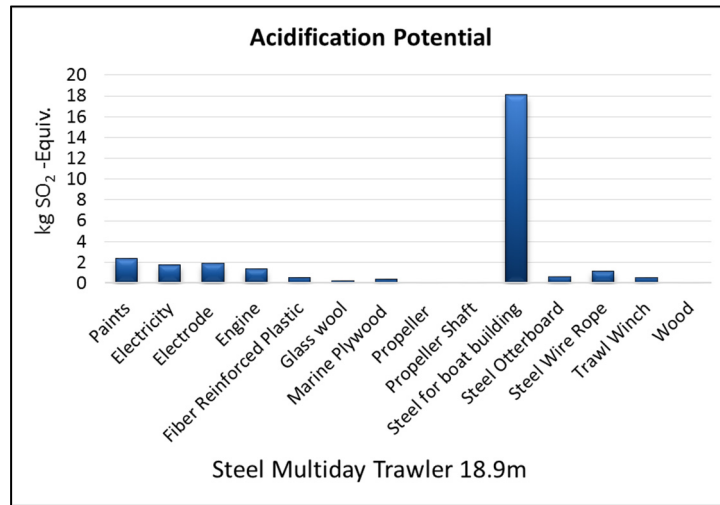

Fig. 4.53 Acidification potential of 18.9 m large steel multi-day trawler

Among the materials used for construction of 19.81 m large steel multi-day trawler, AP was maximum for steel used for construction (62.2%) followed by paints (8.0%), electrode (6.8%), electricity (6.0%), engine (4.5%), steel wire rope (4.1%), steel otterboard (2.1%), trawl winch (1.7%), FRP (1.7%), marine plywood (1.4%), glass wool (0.8%), propeller (0.3%), wood used for construction (0.2%) and propeller shaft (0.2%) (Fig. 4.54).

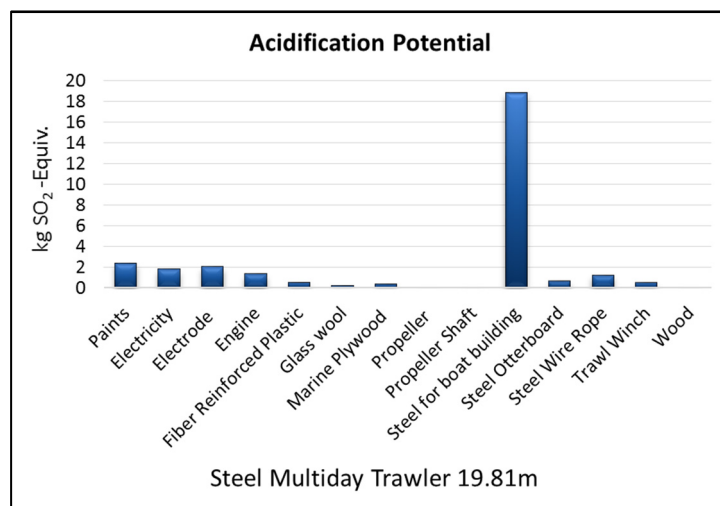

Fig. 4.54 Acidification potential of 19.81 m large steel multi-day trawler

Among the materials used for construction of 21.33 m large steel multi-day trawler, AP was maximum for steel used for construction (61.8%) followed by paints (7.8%), electrode (7.2%), electricity (5.9%), engine (4.9%), steel wire rope (4.1%), steel otterboard (2.2%), FRP (1.7%), trawl winch (1.6%), marine plywood (1.4%), glass wool (0.9%), propeller (0.3%), wood used for construction (0.2%) and propeller shaft (0.2%) (Fig. 4.55).

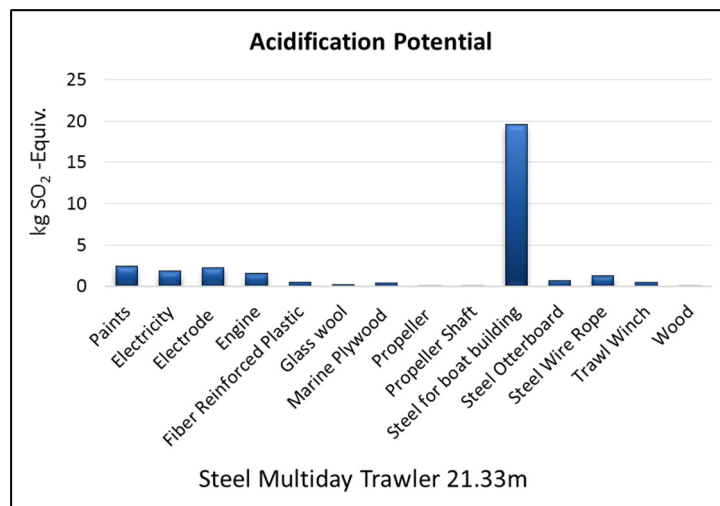

Fig. 4.55 Acidification potential of 21.33 m large steel multi-day trawler

Among the materials used for construction of 22.86 m large steel multi-day trawler, AP was maximum for steel used for construction (61.2%) followed by paints (7.6%), electrode (7.6%), electricity (5.8%), engine (5.2%), steel wire rope (4.1%), steel otterboard (2.5%), FRP (1.6%), trawl winch (1.5%), marine plywood (1.4%), glass wool (0.9%), propeller (0.3%), wood used for construction (0.2%) and propeller shaft (0.2%) (Fig. 4.56).

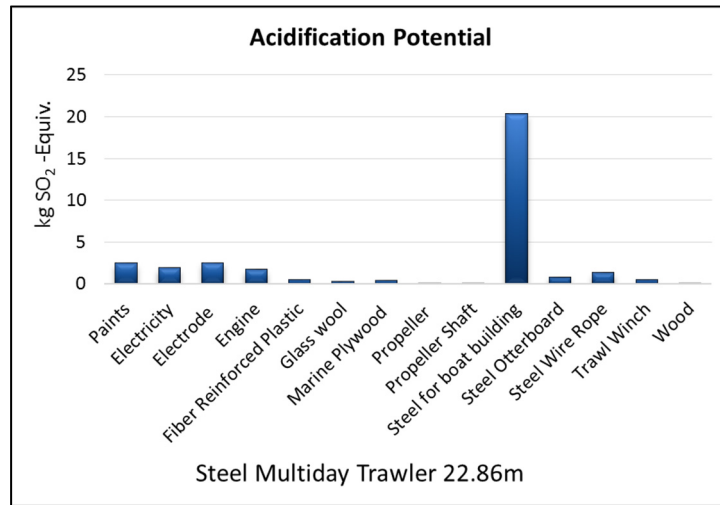

Fig. 4.56 Acidification potential of 22.86 m large steel multi-day trawler

Among the materials used for construction of 24.38 m very large steel multi-day trawler, AP was maximum for steel used for construction (60.7%) followed by electrode (8.2%), paints (7.7%), electricity (6.0%), engine (4.9%), steel wire rope (4.1%), steel otterboard (2.4%), FRP (1.5%), trawl winch (1.5%), marine plywood (1.4%), glass wool (0.9%), propeller (0.3%), wood used for construction (0.2%) and propeller shaft (0.2%) (Fig. 4.57).

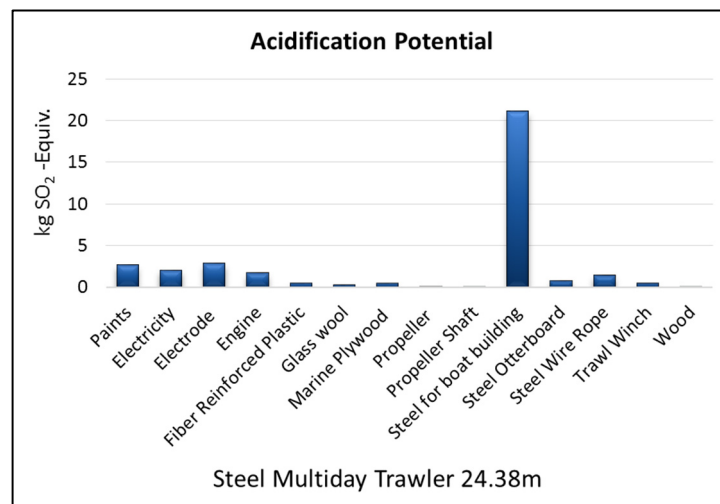

Fig. 4.57 Acidification potential of 24.38 m very large steel multi-day trawler

Among the materials used for construction of 25.9 m very large steel multi-day trawler, AP was maximum for steel used for construction (59.2%) followed by electrode (8.7%), paints (7.7%), electricity (6.4%), engine (4.5%), steel wire rope (3.9%), trawl winch (2.7%), steel otterboard (2.2%), FRP (1.5%), marine plywood (1.4%), glass wool (1.2%), propeller (0.3%), wood used for construction (0.2%) and propeller shaft (0.2%) (Fig. 4.58).

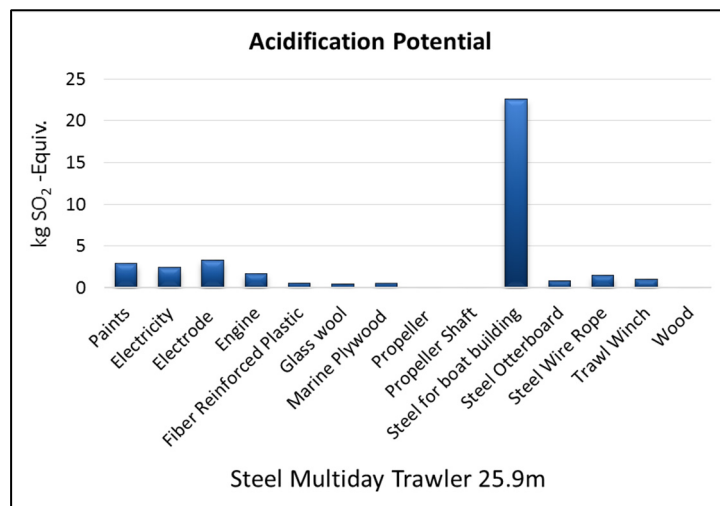

Fig. 4.58 Acidification potential of 25.9 m very large steel multi-day trawler

Among the materials used for construction of 27.43 m very large steel multi-day trawler, AP was maximum for steel used for construction (61.2%) followed by electrode (8.8%), paints (7.0%), electricity (6.6%), engine (4.0%), steel wire rope (3.7%), trawl winch (2.4%), steel otterboard (1.9%), FRP (1.5%), marine plywood (1.3%), glass wool (1.1%), propeller (0.3%), propeller shaft (0.2%) and wood used for construction (0.1%) (Fig. 4.59).

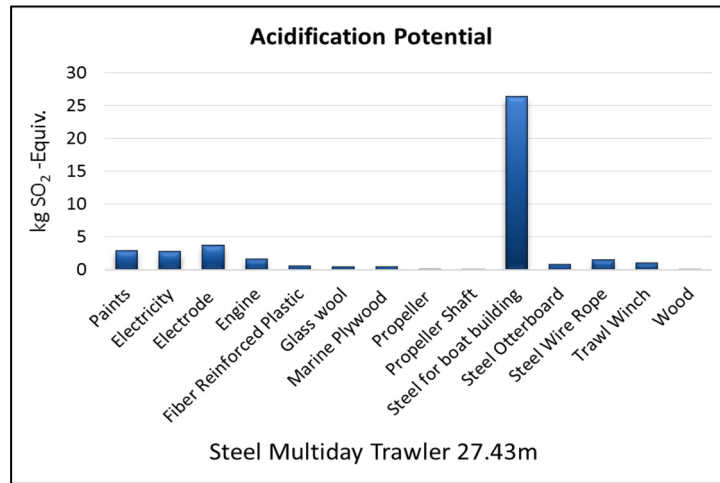

Fig. 4.59 Acidification potential of 27.43 m very large steel multi-day trawler

4.3.7.4 Eutrophication potential

Among the materials used for construction of 10.66 m small wooden single-day trawler, Eutrophication potential (EP) was maximum for engine (19.9%) followed by cotton (16.4%), aluminium sheet (13.6%), steel wire rope (11.9%), marine plywood (8.4%), FRP (7.6%), paints (6.4%), wood used for construction (5.6%), trawl winch (5%), glass wool (1.6%), electricity (1.3%), copper (1%), propeller shaft (0.7%), wooden otterboard (0.4%), steel nail (0.3%) and propeller (0.1%) (Fig. 4.60).

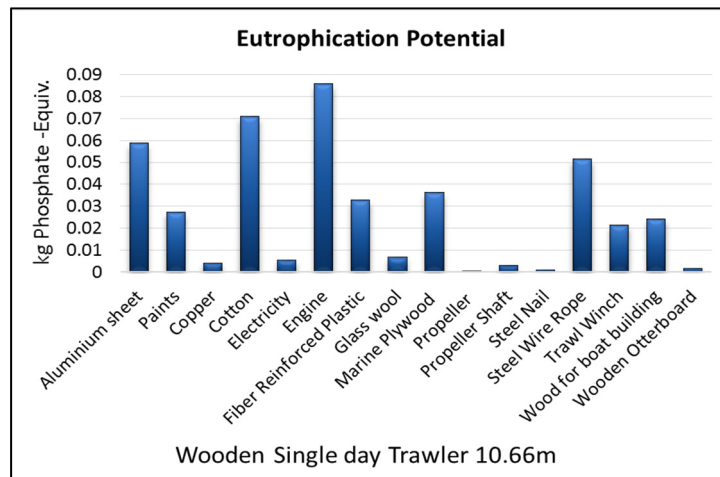

Fig. 4.60 Eutrophication potential of 10.66 m small wooden single-day trawler

Among the materials used for construction of 13.71 m medium wooden multi-day trawler, EP was maximum for cotton (20.3%) followed by engine (15.3%), aluminium sheet (14%), steel wire rope (10.7%), marine plywood (8.3%), FRP (7.6%), paints (6.1%), wood used for construction (5.7%), trawl winch (3.8%), electricity (2.3%), copper (2.3%), glass wool (2%), propeller shaft (0.5%), steel nail (0.4%), wooden otterboard (0.4%) and propeller (0.2%) (Fig. 4.61).

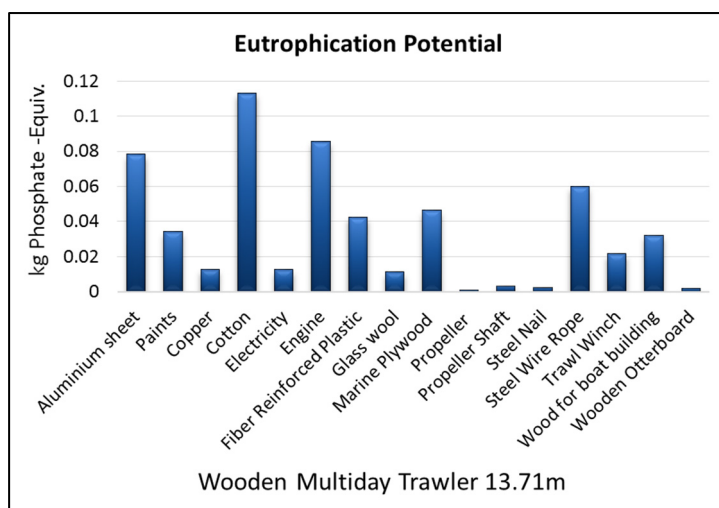

Fig. 4.61 Eutrophication potential of 13.71 m medium wooden multi-day trawler

Among the materials used for construction of 15.3 m medium wooden multi-day trawler, EP was maximum for cotton (21.7%) followed by aluminium sheet (15.7%), engine (12.5%), steel wire rope (10%), marine plywood (7.6%), FRP (6.9%), paints (5.9%), wood used for construction (5.4%), trawl winch (3.8%), glass wool (3.7%), copper (2.8%), electricity (2.5%), propeller shaft (0.4%), steel nail (0.4%), wooden otterboard (0.3%) and propeller (0.2%) (Fig. 4.62).

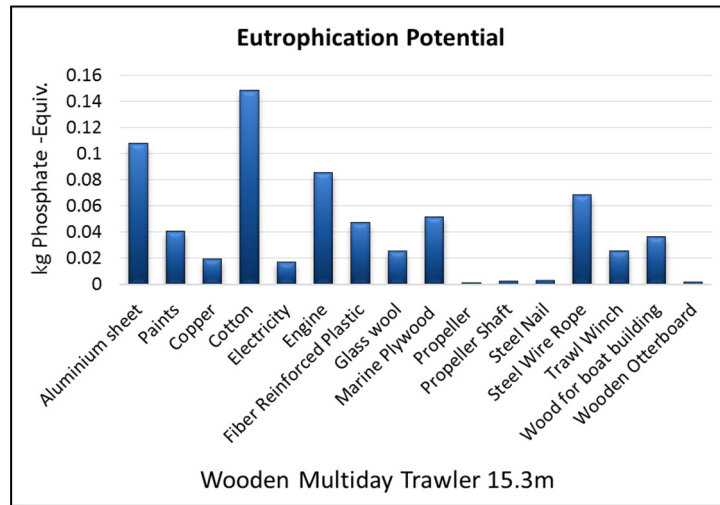

Fig. 4.62 Eutrophication potential of 15.3 m medium wooden multi-day trawler

Among the materials used for construction of 18.9 m large wooden multi-day trawler, EP was maximum for cotton (22.3%) followed by aluminium sheet (15.4%), engine (9.7%), steel wire rope (8.2%), marine plywood (7.2%), FRP (6.6%), paints (5.7%), wood used for construction (5.2%), steel otterboard (4.3%), glass wool (4%), copper (3.8%), trawl winch (3.6%), electricity (2.8%), steel nail (0.5%), propeller shaft (0.4%) and propeller (0.2%) (Fig. 4.63).

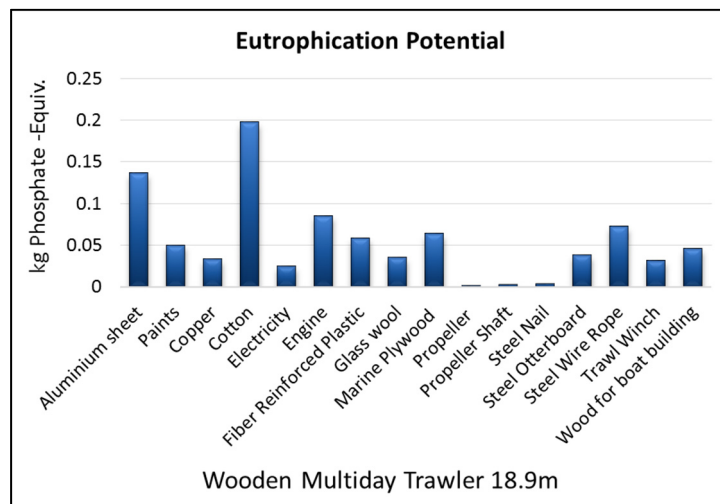

Fig. 4.63 Eutrophication potential of 18.9 m large wooden multi-day trawler

Among the materials used for construction of 19.81 m large wooden multi-day trawler, EP was maximum for cotton (22.4%) followed by aluminium sheet (15.5%), engine (9.1%), steel wire rope (8.2%), marine plywood (7.1%), FRP (6.9%), paints (5.6%), wood used for construction (5.1%), copper (4.5%), steel otterboard (4.3%), glass wool (4%), trawl winch (3.4%), electricity (3%), steel nail (0.5%), propeller shaft (0.3%) and propeller (0.2%) (Fig. 4.64).

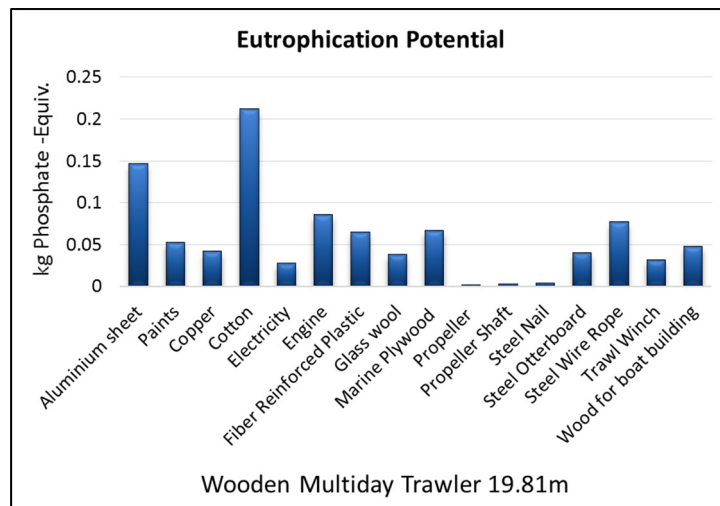

Fig. 4.64 Eutrophication potential of 19.81 m large wooden multi-day trawler

Among the materials used for construction of 21.33 m large wooden multi-day trawler, EP was maximum for cotton (29.8%) followed by aluminium sheet (16.5%), engine (8.1%), steel wire rope (6.8%), marine plywood (6.1%), FRP (5.5%), paints (4.5%), copper (4.6%), wood used for construction (4.5%), steel otterboard (3.6%), glass wool (3.5%), trawl winch (2.7%), electricity (2.7%), steel nail (0.6%), propeller shaft (0.3%) and propeller (0.2%) (Fig. 4.65).

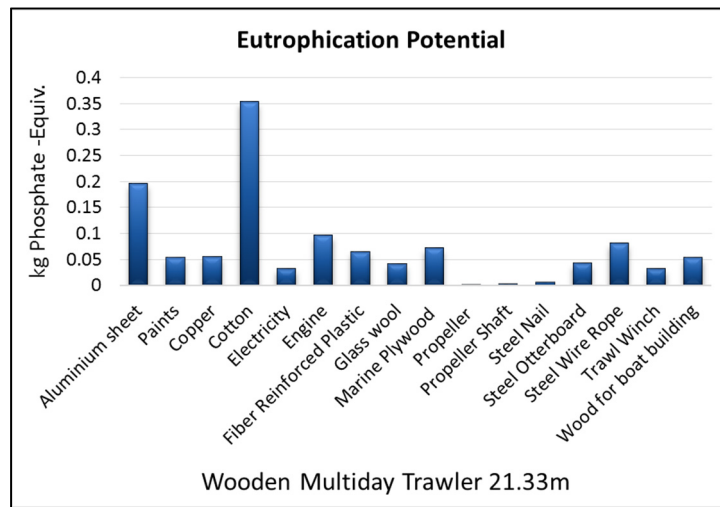

Fig. 4.65 Eutrophication potential of 21.33 m large wooden multi-day trawler

Among the materials used for construction of 13.71 m medium steel multi-day trawler, EP was maximum for steel used for construction (58.5%) followed by electrode (7.3%), engine (7.1%), electricity (6.5%), steel wire rope (5%), marine plywood (3.8%), paints (2.8%), FRP (2.7%), steel otterboard (2.7%), trawl winch (1.8%), glass wool (0.9%), wood used for construction (0.6%), propeller shaft (0.2%) and propeller (0.1%) (Fig. 4.66).

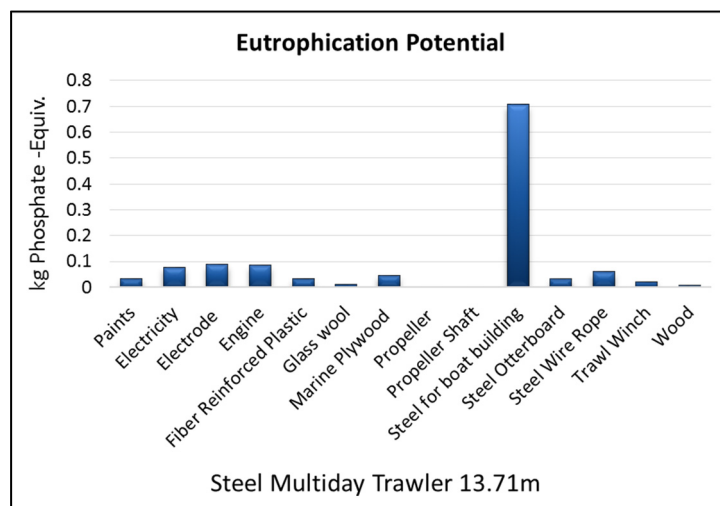

Fig. 4.66 Eutrophication potential of 13.71 m medium steel multi-day trawler

Among the materials used for construction of 15.3 m medium steel multi-day trawler, EP was maximum for steel used for construction (59.7%) followed by electrode (6.4%), engine (6%), electricity (6.1%), steel wire rope (4.8%), marine plywood (3.7%), FRP (3.3%), paints (2.9%), steel otterboard (2.4%), trawl winch (1.8%), glass wool (1.8%), wood used for construction (0.7%), propeller shaft (0.2%) and propeller (0.1%) (Fig. 4.67).

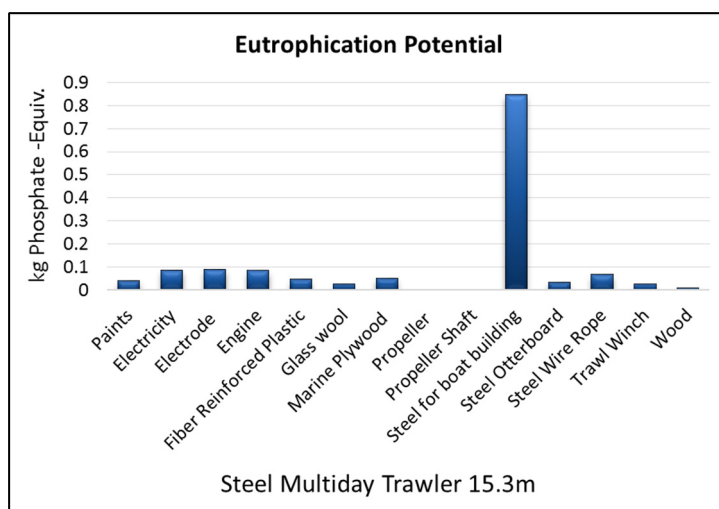

Fig. 4.67 Eutrophication potential of 15.3 m medium steel multi-day trawler

Among the materials used for construction of 18.9 m large steel multi-day trawler, EP was maximum for steel used for construction (63.1%) followed by electricity (5.6%), electrode (5.3%), engine (4.8%), steel wire rope (4.1%), FRP (3.7%), marine plywood (3.6%), paints (3.1%), steel otterboard (2.2%), glass wool (2.0%), trawl winch (1.8%), wood used for construction (0.6%), propeller shaft (0.2%) and propeller (0.1%) (Fig. 4.68).

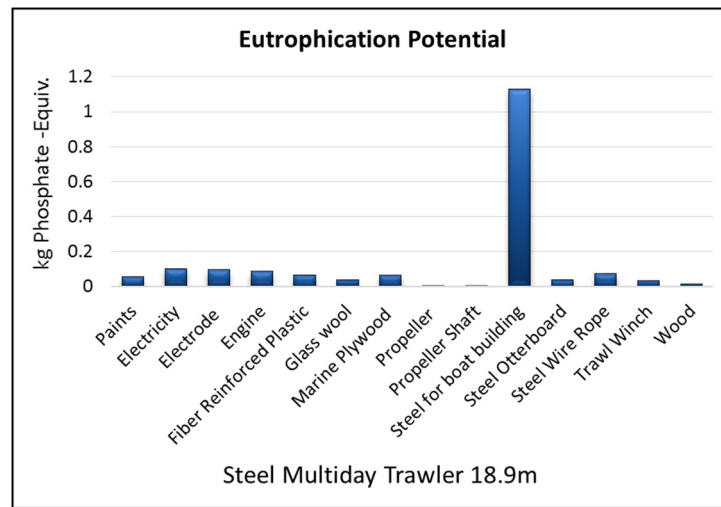

Fig. 4.68 Eutrophication potential of 18.9 m large steel multi-day trawler

Among the materials used for construction of 19.81 m large steel multi-day trawler, EP was maximum for steel used for construction (63.2%) followed by electricity (5.5%), electrode (5.5%), engine (4.6%), steel wire rope (4.1%), marine plywood (3.7%), FRP (3.5%), paints (3.0%), steel otterboard (2.2%), glass wool (2.0%), trawl winch (1.7%), wood used for construction (0.6%), propeller shaft (0.2%) and propeller (0.1%) (Fig. 4.69).

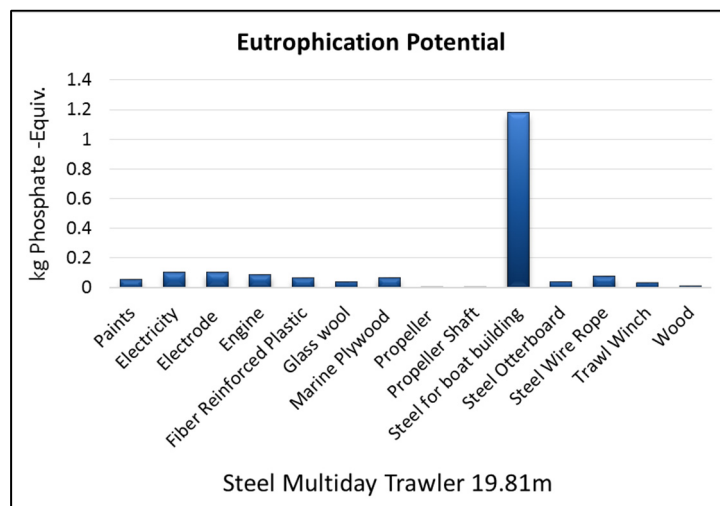

Fig. 4.69 Eutrophication potential of 19.81 m large steel multi-day trawler

Among the materials used for construction of 21.33 m large steel multi-day trawler, EP was maximum for steel used for construction (62.8%) followed by electrode (5.8%), electricity (5.4%), engine (4.9%), steel wire rope (4.2%), marine plywood (3.7%), FRP (3.4%), paints (2.9%), steel otterboard (2.2%), glass wool (2.1%), trawl winch (1.6%), wood used for construction (0.6%), propeller shaft (0.2%) and propeller (0.1%) (Fig. 4.70).

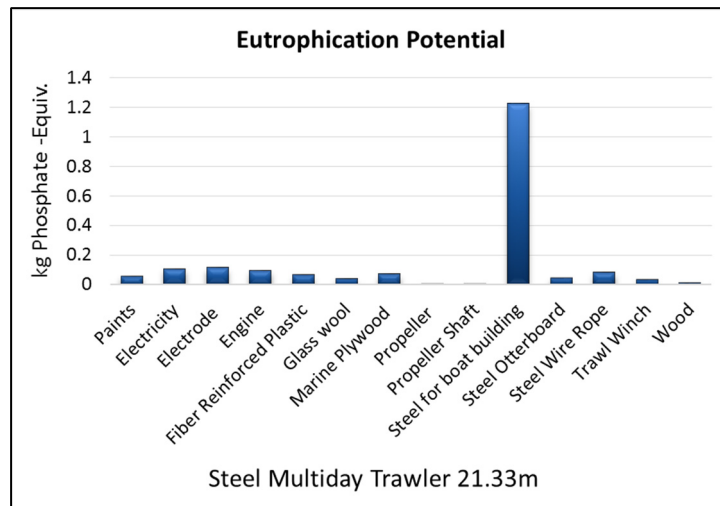

Fig. 4.70 Eutrophication potential of 21.33 m large steel multi-day trawler

Among the materials used for construction of 22.86 m large steel multi-day trawler, EP was maximum for steel used for construction (62.1%) followed by electrode (6.2%), electricity (5.3%), engine (5.2%), steel wire rope (4.2%), marine plywood (3.8%), FRP (3.2%), paints (2.8%), steel otterboard (2.5%), glass wool (2.2%), trawl winch (1.6%), wood used for construction (0.6%), propeller shaft (0.2%) and propeller (0.1%) (Fig. 4.71).

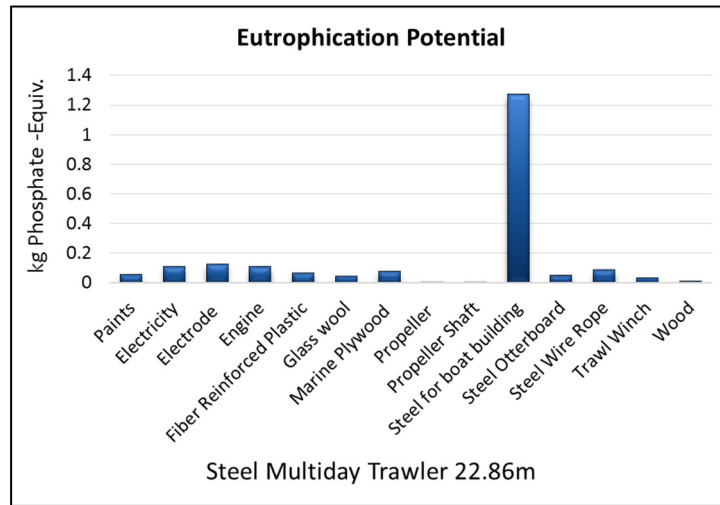

Fig. 4.71 Eutrophication potential of 22.86 m large steel multi-day trawler

Among the materials used for construction of 24.38 m very large steel multi-day trawler, EP was maximum for steel used for construction (61.8%) followed by electrode (6.7%), electricity (5.5%), engine (5.0%), steel wire rope (4.2%), marine plywood (3.9%), FRP (3.1%), paints (3.0%), steel otterboard (2.4%), glass wool (2.3%), trawl winch (1.5%), wood used for construction (0.5%), propeller shaft (0.2%) and propeller (0.1%) (Fig. 4.72).

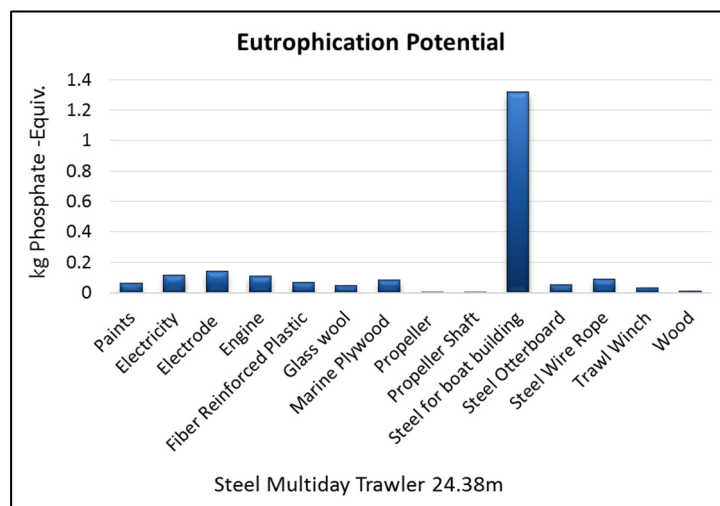

Fig. 4.72 Eutrophication potential of 24.38 m very large steel multi-day trawler

Among the materials used for construction of 25.9 m very large steel multi-day trawler, EP was maximum for steel used for construction (60.0%) followed by electrode (7.0%), electricity (5.8%), engine (4.5%), steel wire rope (4.0%), marine plywood (3.7%), FRP (3.1%), glass wool (3.0%), paints (2.8%), trawl winch (2.7%), steel otterboard (2.2%), wood used for construction (0.6%), propeller shaft (0.2%) and propeller (0.1%) (Fig. 4.73).

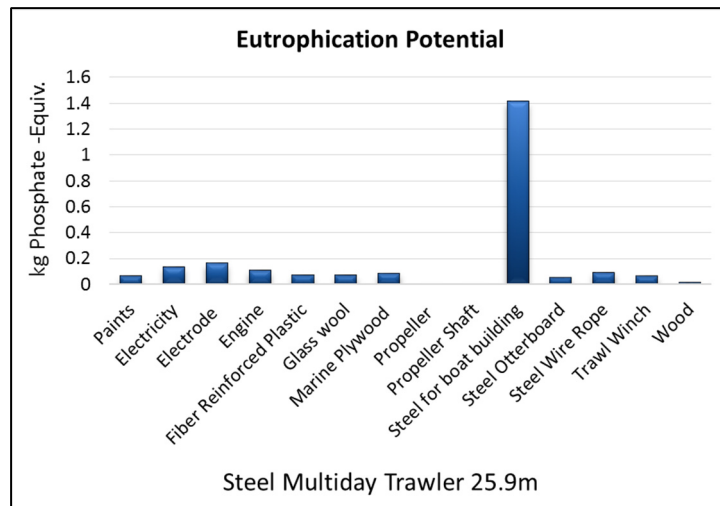

Fig. 4.73 Eutrophication potential of 25.9 m very large steel multi-day trawler

Among the materials used for construction of 27.43 m very large steel multi-day trawler, EP was maximum for steel used for construction (62.1%) followed by electrode (7.1%), electricity (6.0%), engine (4.0%), steel wire rope (3.7%), marine plywood (3.5%), FRP (3.0%), glass wool (2.8%), paints (2.5%), trawl winch (2.4%), steel otterboard (1.9%), wood used for construction (0.5%), propeller shaft (0.2%) and propeller (0.1%) (Fig. 4.74).

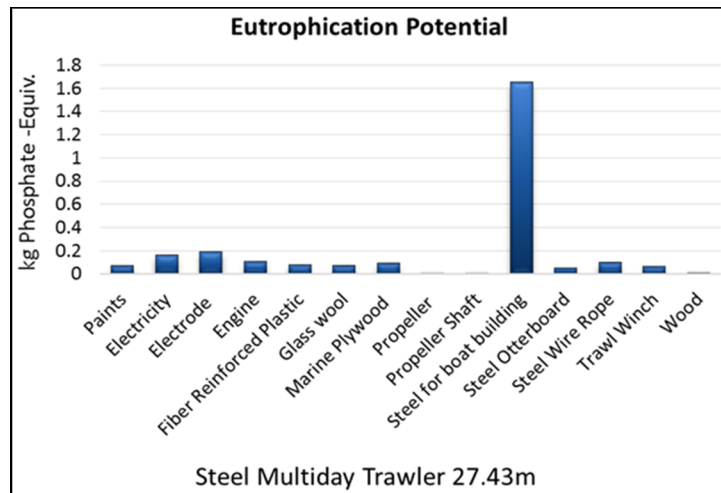

Fig. 4.74 Eutrophication potential of 27.43 m very large steel multi-day trawler

4.3.7.5 Marine aquatic ecotoxicity potential

Among the materials used for construction of 10.66 m small wooden single-day trawler, Marine aquatic ecotoxicity potential (MAETP) was maximum for aluminium sheet (53.3%) followed by engine (17.1%), steel wire rope (10.3%), marine plywood (9.3%), trawl winch (4.3%), electricity (2.5%), paints (0.7%), FRP (0.6%), propeller shaft (0.6%), copper (0.5%), wood used for construction (0.2%), glass wool (0.2%), steel nail (0.2%), cotton (0.1%) and propeller (0.1%) (Fig. 4.75).

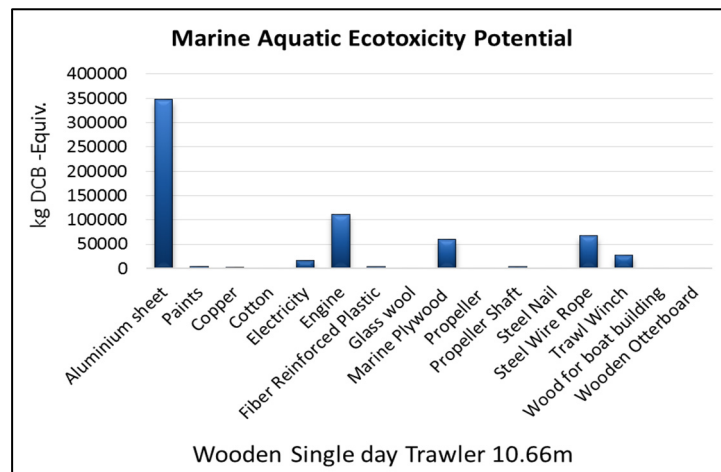

Fig. 4.75 Marine aquatic ecotoxicity potential of 10.66 m small wooden single-day trawler

Among the materials used for construction of 13.71 m medium wooden multi-day trawler, MAETP was maximum for aluminium sheet (55.3%) followed by engine (13.5%), steel wire rope (9.4%), marine plywood (9.3%), electricity (4.4%), trawl winch (3.4%), copper (1.2%), paints (0.7%), FRP (0.6%), propeller shaft (0.5%), steel nail (0.4%), glass wool (0.3%), wood used for construction (0.2%), cotton (0.1%) and propeller (0.1%) (Fig. 4.76).

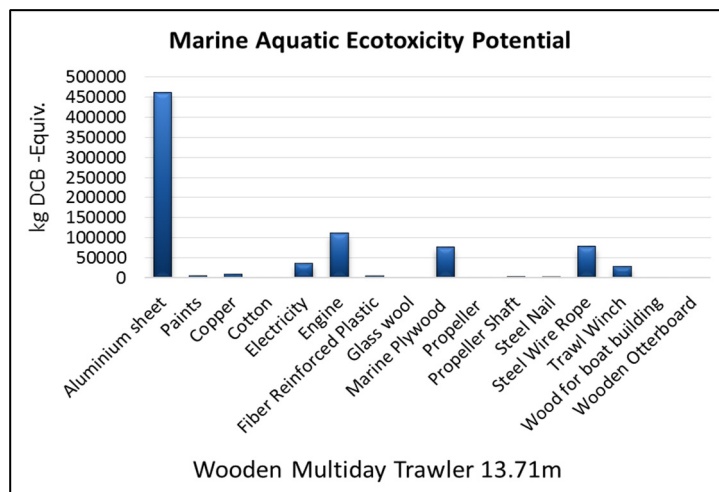

Fig. 4.76 Marine aquatic ecotoxicity potential of 13.71 m medium wooden multi-day trawler

Among the materials used for construction of 15.3 m medium wooden multi-day trawler, MAETP was maximum for aluminium sheet (60.4%) followed by engine (10.6%), steel wire rope (8.5%), marine plywood (8.2%), electricity (4.8%), trawl winch (3.2%), copper (1.4%), paints (0.7%), FRP (0.5%), glass wool (0.5%), propeller shaft (0.4%), steel nail (0.4%), wood used for construction (0.2%), propeller (0.2%) and cotton (0.1%) (Fig. 4.77).

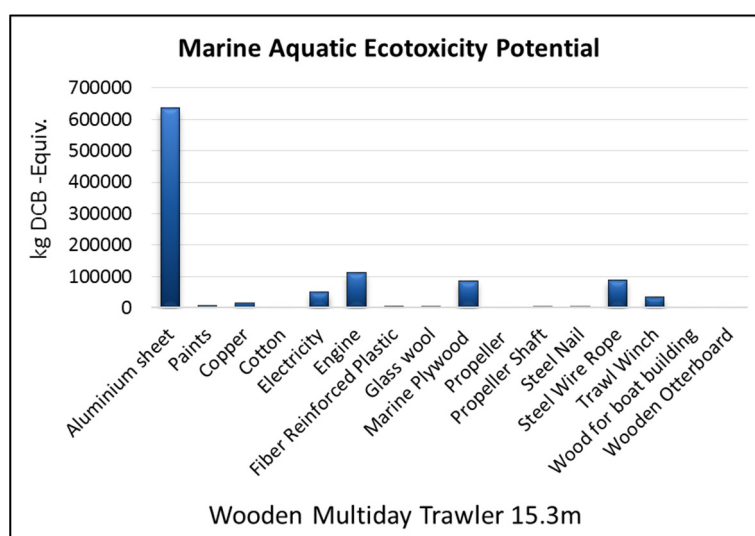

Fig. 4.77 Marine aquatic ecotoxicity potential of 15.3 m medium wooden multi-day trawler

Among the materials used for construction of 18.9 m large wooden multi-day trawler, MAETP was maximum for aluminium sheet (59.9%) followed by engine (8.3%), marine plywood (7.9%), steel wire rope (7%), electricity (5.4%), steel otterboard (3.7%), trawl winch (3.1%), copper (2%), paints (0.7%), FRP (0.5%), glass wool (0.5%), steel nail (0.4%), propeller shaft (0.3%), wood used for construction (0.2%), propeller (0.2%) and cotton (0.1%) (Fig. 4.78).

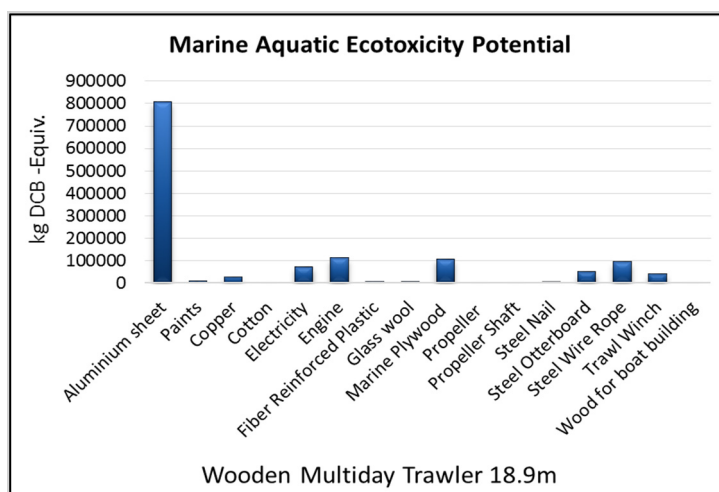

Fig. 4.78 Marine aquatic ecotoxicity potential of 18.9 m large wooden multi-day trawler

Among the materials used for construction of 19.81 m large wooden multi-day trawler, MAETP was maximum for aluminium sheet (60.2%) followed by engine (7.7%), marine plywood (7.7%), steel wire rope (7%), electricity (5.6%), steel otterboard (3.7%), trawl winch (2.9%), copper (2.3%), paints (0.6%), FRP (0.6%), glass wool (0.5%), steel nail (0.4%), propeller shaft (0.3%), wood used for construction (0.2%), propeller (0.2%) and cotton (0.1%) (Fig. 4.79).

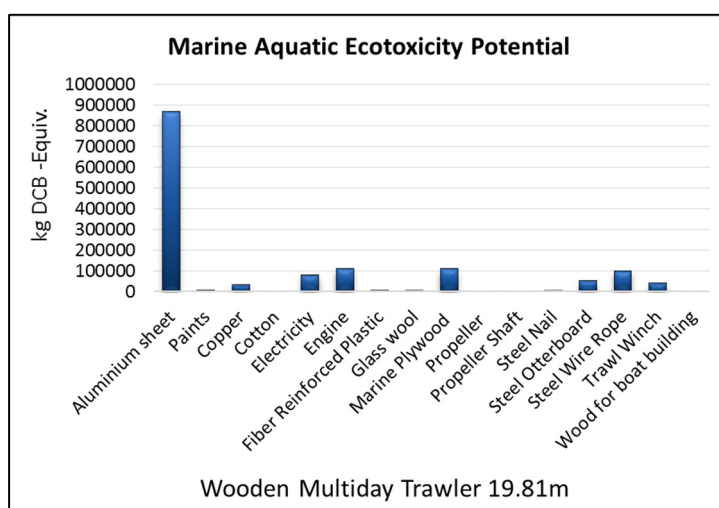

Fig. 4.79 Marine aquatic ecotoxicity potential of 19.81 m large wooden multi-day trawler

Among the materials used for construction of 21.33 m large wooden multi-day trawler, MAETP was maximum for aluminium sheet (64.6%) followed by engine (7%), marine plywood (6.7%), steel wire rope (5.9%), electricity (5.2%), steel otterboard (3.1%), copper (2.4%), trawl winch (2.3%), paints (0.5%), steel nail (0.5%), FRP (0.4%), glass wool (0.4%), propeller shaft (0.2%), cotton (0.2%), wood used for construction (0.1%) and propeller (0.1%) (Fig. 4.80).

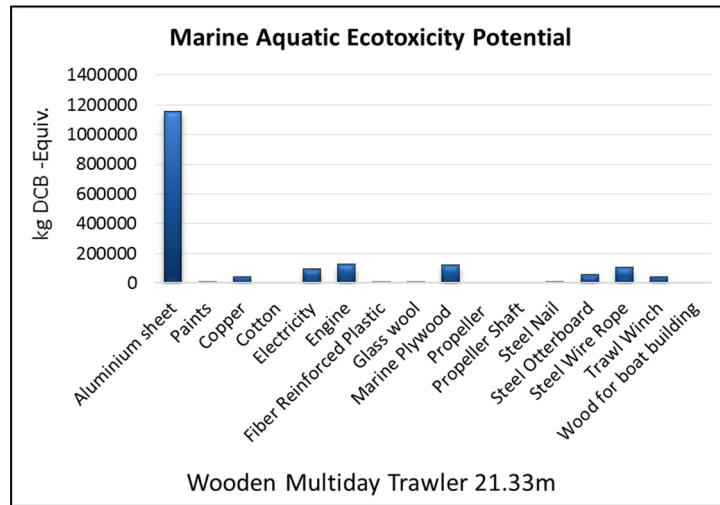

Fig. 4.80 Marine aquatic ecotoxicity potential of 21.33 m large wooden multi-day trawler

Among the materials used for construction of 13.71 m medium steel multi-day trawler, MAETP was maximum for steel used for construction (60.7%) followed by electricity (14.9%), engine (7.4%), marine plywood (5.1%), steel wire rope (5.1%), steel otterboard (2.8%), trawl winch (1.8%), electrode (1%), paints (0.4%), FRP (0.3%), propeller shaft (0.3%), glass wool (0.1%) and propeller (0.1%) (Fig. 4.81).

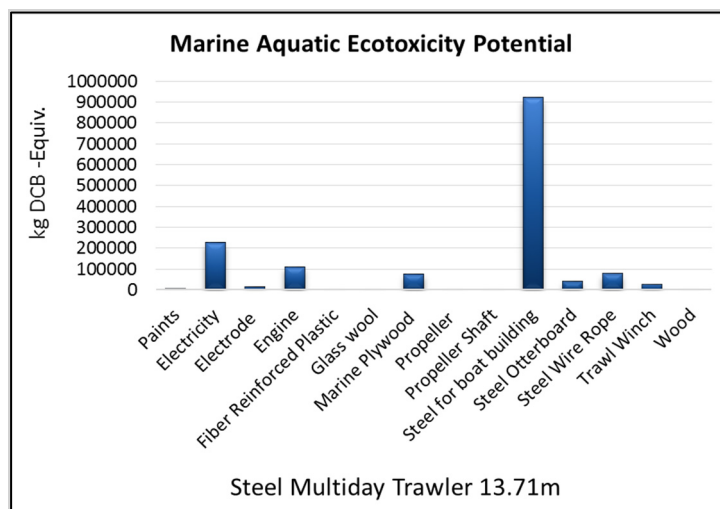

Fig. 4.81 Marine aquatic ecotoxicity potential of 13.71 m medium steel multi-day trawler

Among the materials used for construction of 15.3 m medium steel multi-day trawler, MAETP was maximum for steel used for construction (62.7%) followed by electricity (14.2%), engine (6.3%), steel wire rope (5.1%), marine plywood (4.9%), steel otterboard (2.5%), trawl winch (1.9%), electrode (0.9%), paints (0.5%), FRP (0.3%), glass wool (0.3%), propeller shaft (0.2%) and propeller (0.1%) (Fig. 4.82).

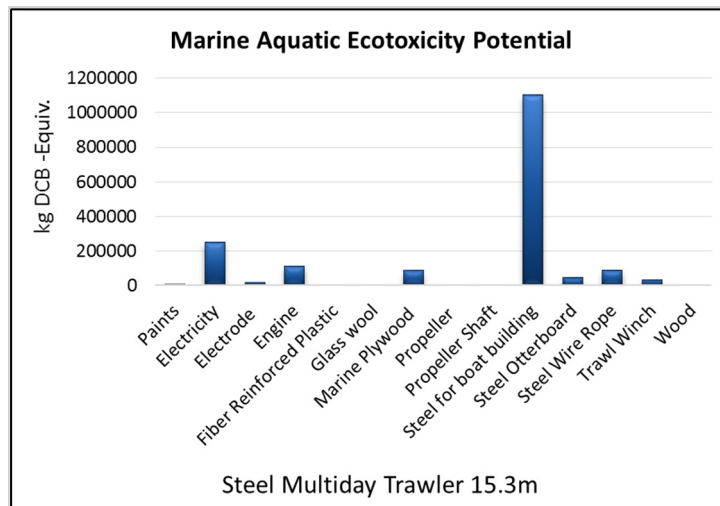

Fig. 4.82 Marine aquatic ecotoxicity potential of 15.3 m medium steel multi-day trawler

Among the materials used for construction of 18.9 m large steel multi-day trawler, MAETP was maximum for steel used for construction (66.4%) followed by electricity (13.1%), engine (5.0%), marine plywood (4.8%), steel wire rope (4.3%), steel otterboard (2.3%), trawl winch (1.9%), electrode (0.7%), paints (0.5%), FRP (0.4%), glass wool (0.3%), propeller shaft (0.2%) and propeller (0.1%) (Fig. 4.83).

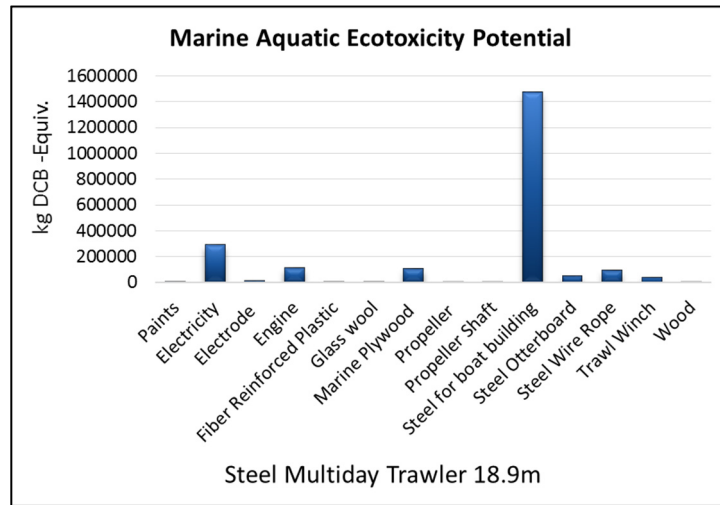

Fig. 4.83 Marine aquatic ecotoxicity potential of 18.9 m large steel multi-day trawler

Among the materials used for construction of 19.81 m large steel multi-day trawler, MAETP was maximum for steel used for construction (66.6%) followed by electricity (12.9%), marine plywood (4.9%), engine (4.8%), steel wire rope (4.4%), steel otterboard (2.3%), trawl winch (1.8%), electrode (0.8%), paints (0.5%), FRP (0.3%), glass wool (0.3%), propeller shaft (0.2%) and propeller (0.1%) (Fig. 4.84).

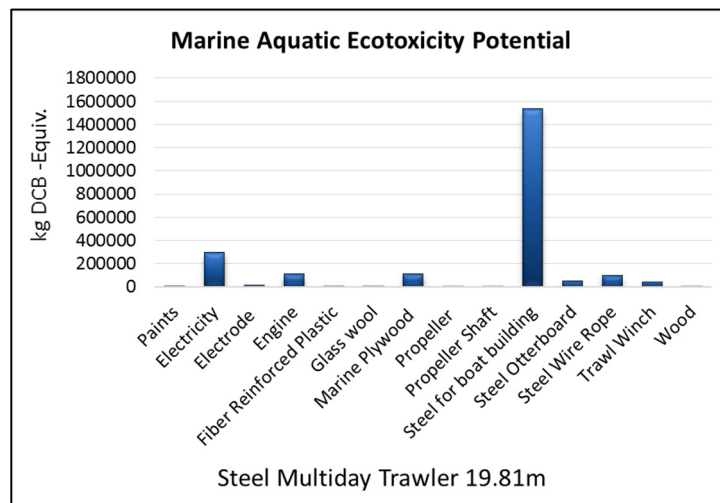

Fig. 4.84 Marine aquatic ecotoxicity potential of 19.81 m large steel multi-day trawler

Among the materials used for construction of 21.33 m large steel multi-day trawler, MAETP was maximum for steel used for construction (66.4%) followed by electricity (12.7%), engine (5.2%), marine plywood (5.0%), steel wire rope (4.4%), steel otterboard (2.3%), trawl winch (1.7%), electrode (0.8%), paints (0.4%), FRP (0.3%), glass wool (0.3%), propeller shaft (0.2%) and propeller (0.1%) (Fig. 4.85).

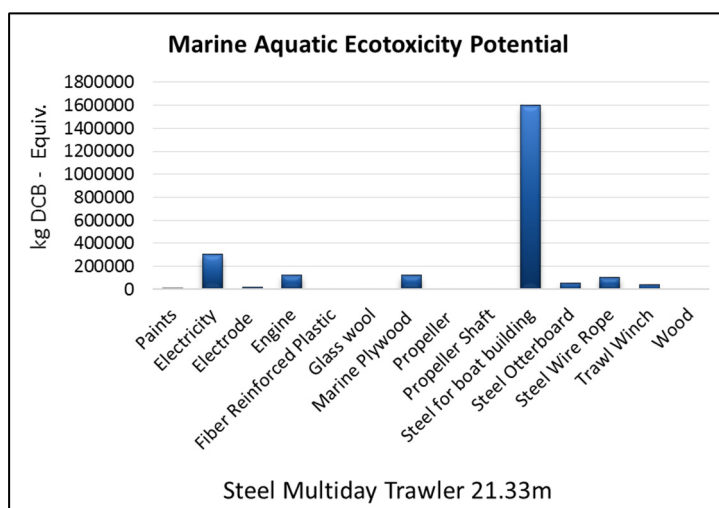

Fig. 4.85 Marine aquatic ecotoxicity potential of 21.33 m large steel multi-day trawler

Among the materials used for construction of 22.86 m large steel multi-day trawler, MAETP was maximum for steel used for construction (65.8%) followed by electricity (12.5%), engine (5.5%), marine plywood (5.1%), steel wire rope (4.4%), steel otterboard (2.7%), trawl winch (1.7%), electrode (0.9%), paints (0.4%), FRP (0.3%), glass wool (0.3%), propeller shaft (0.2%) and propeller (0.1%) (Fig. 4.86).

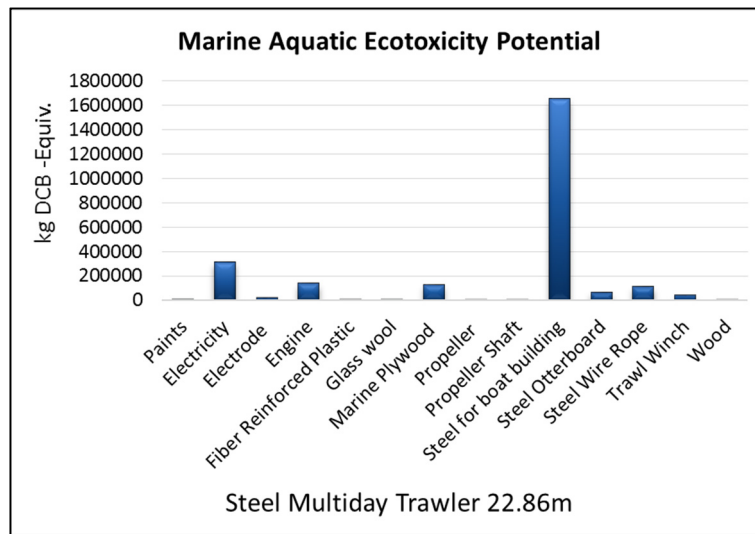

Fig. 4.86 Marine aquatic ecotoxicity potential of 22.86 m large steel multi-day trawler

Among the materials used for construction of 24.38 m very large steel multi-day trawler, MAETP was maximum for steel used for construction (65.5%) followed by electricity (12.9%), engine (5.3%), marine plywood (5.2%), steel wire rope (4.5%), steel otterboard (2.6%), trawl winch (1.6%), electrode (0.9%), paints (0.5%), FRP (0.3%), glass wool (0.3%), propeller shaft (0.2%) and propeller (0.1%) (Fig. 4.87).

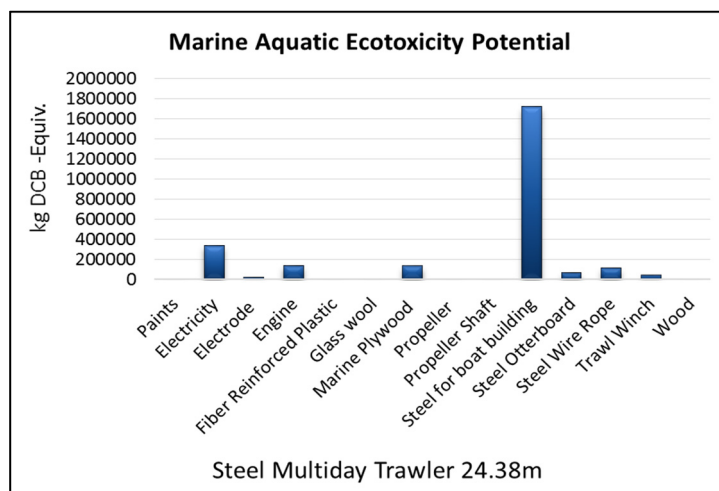

Fig. 4.87 Marine aquatic ecotoxicity potential of 24.38 m very large steel multi-day trawler

Among the materials used for construction of 25.9 m very large steel multi-day trawler, MAETP was maximum for steel used for construction (64.1%) followed by electricity (13.8%), marine plywood (5.1%), engine (4.9%), steel wire rope (4.3%), trawl winch (2.9%), steel otterboard (2.3%), electrode (1.0%), glass wool (0.5%), paints (0.4%), FRP (0.3%), propeller shaft (0.3%) and propeller (0.1%) (Fig. 4.88).

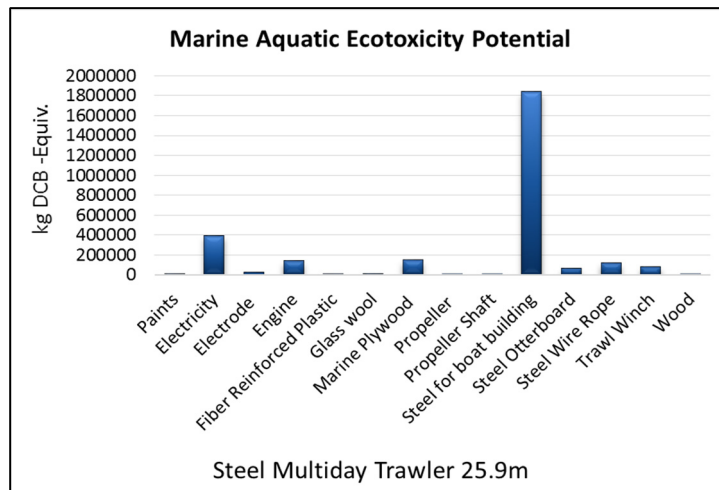

Fig. 4.88 Marine aquatic ecotoxicity potential of 25.9 m very large steel multi-day trawler

Among the materials used for construction of 27.43 m very large steel multi-day trawler, MAETP was maximum for steel used for construction (65.9%) followed by electricity (14.1%), marine plywood (4.7%), engine (4.3%), steel wire rope (3.9%), trawl winch (2.6%), steel otterboard (2.1%), electrode (1.0%), paints (0.4%), glass wool (0.4%), FRP (0.3%), propeller shaft (0.2%) and propeller (0.1%) (Fig. 4.89).

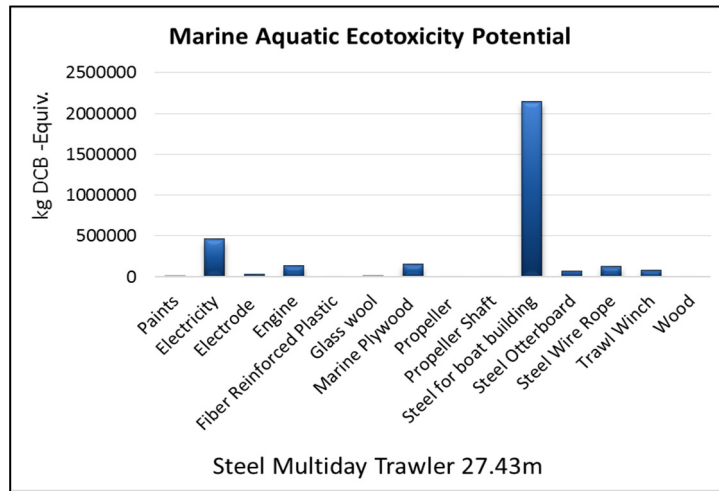

Fig. 4.89 Marine aquatic ecotoxicity potential of 27.43 m very large steel multi-day trawler

4.3.7.6 Ozone depletion potential

Among the materials used for construction of 10.66 m small wooden single-day trawler, Ozone depletion potential (ODP) was maximum for copper (50.7%) followed by aluminium sheet (41.7%), paints (3%), FRP (1.4%), engine (0.8%), glass wool (0.7%), steel wire rope (0.5%), marine plywood (0.5%), wood used for construction (0.2%) trawl winch (0.2%) electricity (0.1%) and cotton (0.1%) (Fig. 4.90).

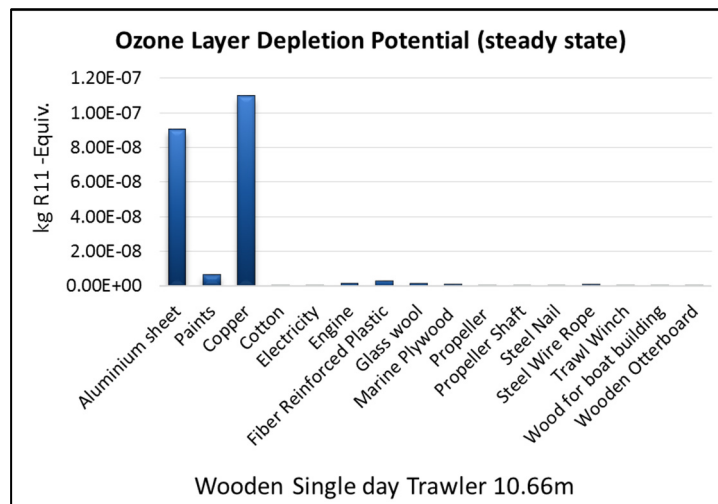

Fig. 4.90 Ozone depletion potential of 10.66 m small wooden single-day trawler

Among the materials used for construction of 13.71 m medium wooden multi-day trawler, ODP was maximum for copper (70%) followed by aluminium sheet (25.6%), paints (1.7%), FRP (0.9%), glass wool (0.6%), engine (0.4%), steel wire rope (0.3%), marine plywood (0.3%), wood used for construction (0.1%), trawl winch (0.1%) and electricity (0.1%) (Fig. 4.91).

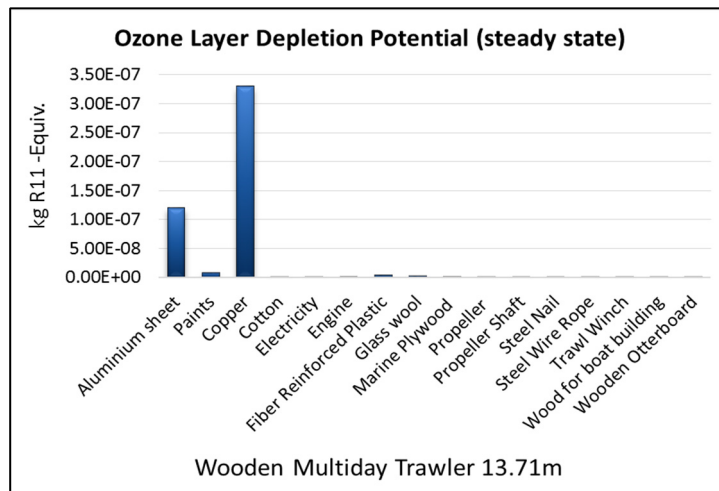

Fig. 4.91 Ozone depletion potential of 13.71 m medium wooden multi-day trawler

Among the materials used for construction of 15.3 m medium wooden multi-day trawler, ODP was maximum for copper (72.4%) followed by aluminium sheet (23.7%), paints (1.3%), glass wool (0.9%), FRP (0.6%), engine (0.2%), steel wire rope (0.2%), marine plywood (0.2%), wood used for construction (0.1%), trawl winch (0.1%) and electricity (0.1%) (Fig. 4.92).

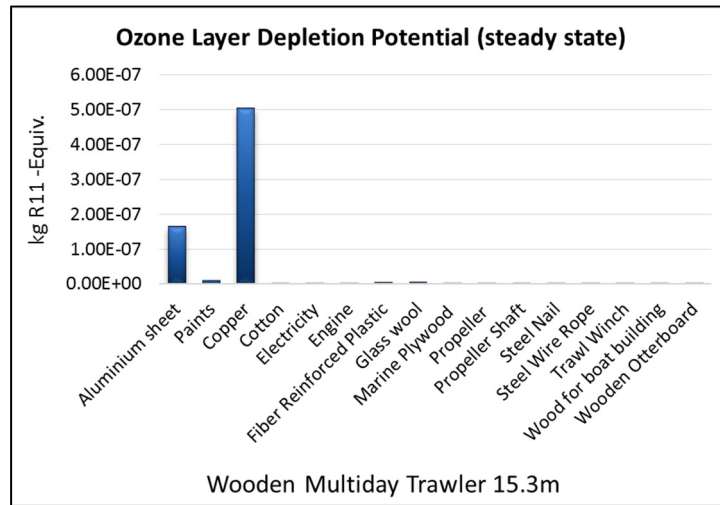

Fig. 4.92 Ozone depletion potential of 15.3 m medium wooden multi-day trawler

Among the materials used for construction of 18.9 m large wooden multi-day trawler, ODP was maximum for copper (78.1%) followed by aluminium sheet (18.7%), paints (1%), glass wool (0.7%), FRP (0.5%), engine (0.2%), marine plywood (0.2%), steel wire rope (0.1%), steel otterboard (0.1%), wood used for construction (0.1%), trawl winch (0.1%) and electricity (0.1%) (Fig. 4.93).

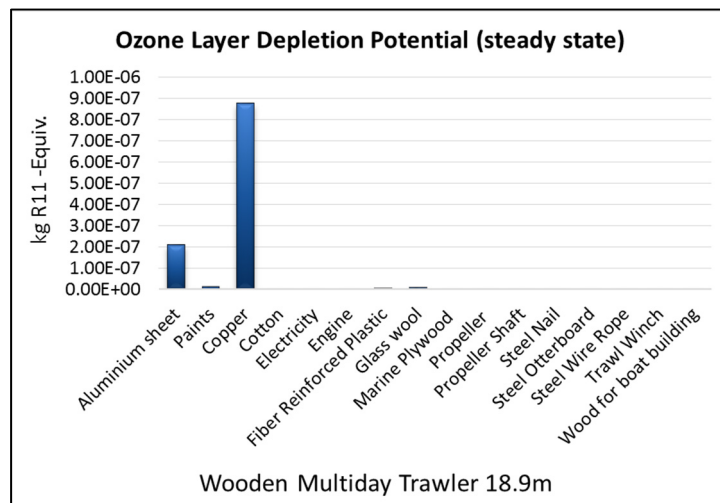

Fig. 4.93 Ozone depletion potential of 18.9 m large wooden multi-day trawler

Among the materials used for construction of 19.81 m large wooden multi-day trawler, ODP was maximum for copper (80.7%) followed by aluminium sheet (16.6%), paints (0.9%), glass wool (0.7%), FRP (0.5%), marine plywood (0.2%), steel wire rope (0.1%), engine (0.1%), wood used for construction (0.1%), steel otterboard (0.1%) and electricity (0.1%) (Fig. 4.94).

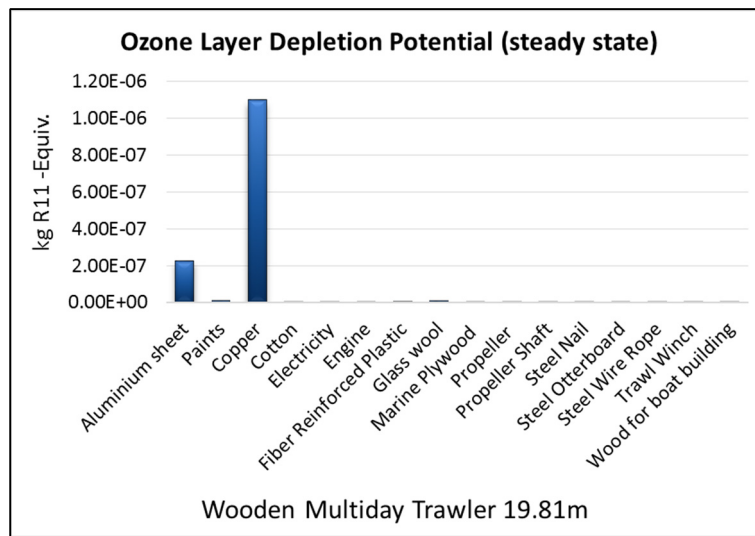

Fig. 4.94 Ozone depletion potential of 19.81 m large wooden multi-day trawler

Among the materials used for construction of 21.33 m large wooden multi-day trawler, ODP was maximum for copper (80.7%) followed by aluminium sheet (17%), paints (0.7%), glass wool (0.6%), FRP (0.4%), engine (0.1%), steel wire rope (0.1%), marine plywood (0.1%), wood used for construction (0.1%) and electricity (0.1%) (Fig. 4.95).

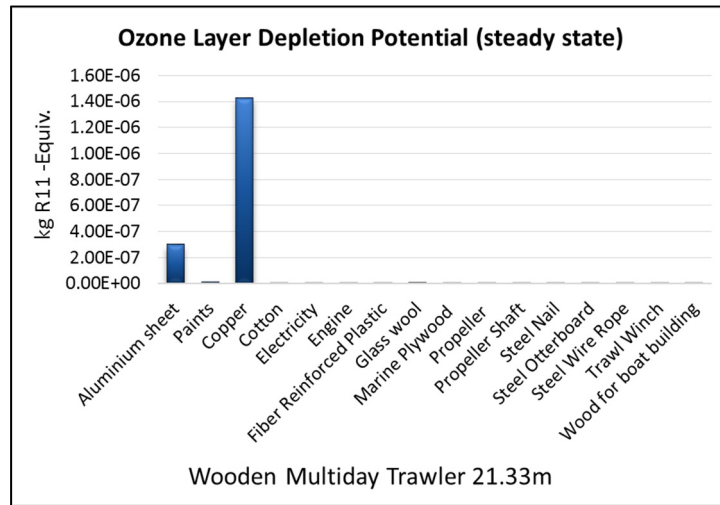

Fig. 4.95 Ozone depletion potential of 21.33 m large wooden multi-day trawler

Among the materials used for construction of 13.71 m medium steel multi-day trawler, ODP was maximum for steel used for construction (33.2%) followed by paints (19%), electrode (12%), electricity (8.1%), FRP (7.4%), glass wool (6.4), engine (4%), marine plywood (3.6%), steel wire rope (2.8%), steel otterboard (1.5%), trawl winch (1%), propeller (0.5%), wood used for construction (0.3%) and propeller shaft (0.1%) (Fig. 4.96).

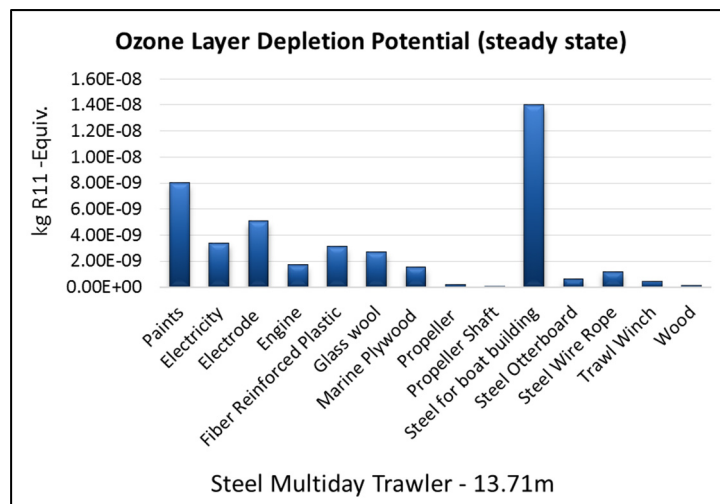

Fig. 4.96 Ozone depletion potential of 13.71 m medium steel multi-day trawler

Among the materials used for construction of 15.3 m medium steel multi-day trawler, ODP was maximum for steel used for construction (32%) followed by paints (18.6%), glass wool (11.5%), electrode (9.9%), FRP (8.6%), electricity (7.2%), marine plywood (3.2%), engine (3.2%), steel wire rope (2.6%), steel otterboard (1.3%), trawl winch (1.0%), propeller (0.5%), wood used for construction (0.3%) and propeller shaft (0.1%) (Fig. 4.97).

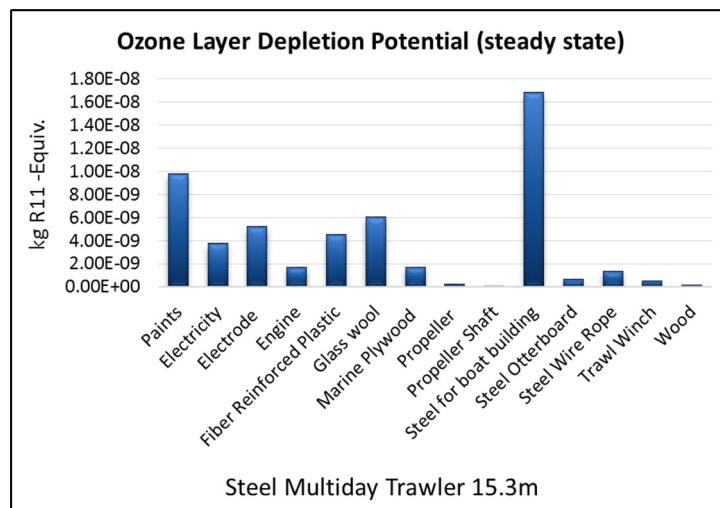

Fig. 4.97 Ozone depletion potential of 15.3 m medium steel multi-day trawler

Among the materials used for construction of 18.9 m large steel multi-day trawler, Ozone depletion potential was maximum for steel used for construction (33.5%) followed by paints (19.1%), glass wool (12.6%), FRP (9.3%), electrode (8.1%), electricity (6.5%), marine plywood (3.2%), engine (2.5%), steel wire rope (2.2%), steel otterboard (1.1%), trawl winch (1%) propeller (0.5%), wood used for construction (0.3%) and propeller shaft (0.1%) (Fig. 4.98).

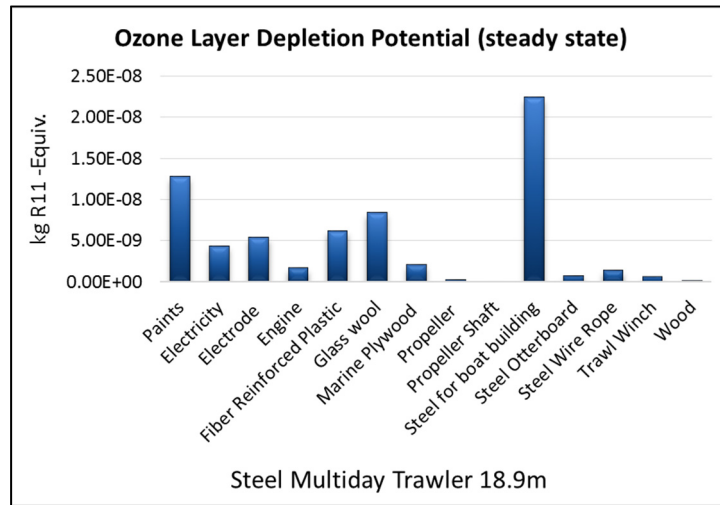

Fig. 4.98 Ozone depletion potential of 18.9 m large steel multi-day trawler

Among the materials used for construction of 19.81 m large steel multi-day trawler, ODP was maximum for steel used for construction (33.6%) followed by paints (18.6%), glass wool (13.1%), FRP (9%), electrode (8.4%), electricity (6.4%), marine plywood (3.2%), engine (2.4%), steel wire rope (2.2%), steel otterboard (1.2%), trawl winch (0.9%), propeller (0.5%), wood used for construction (0.3%) and propeller shaft (0.1%) (Fig. 4.99).

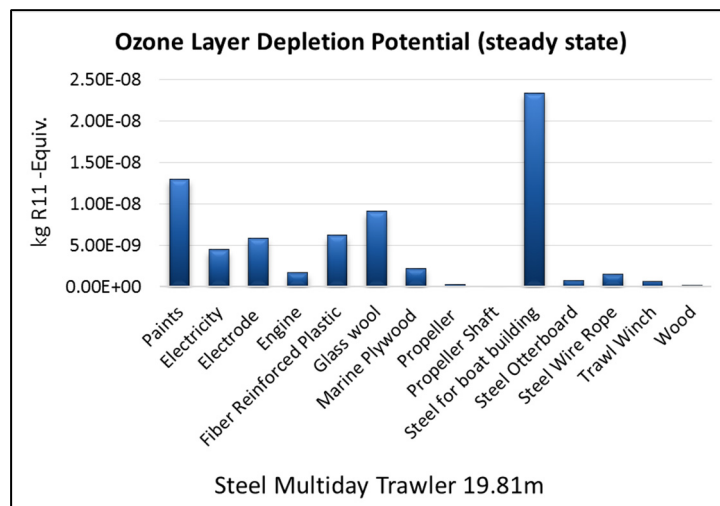

Fig. 4.99 Ozone depletion potential of 19.81 m large steel multi-day trawler

Among the materials used for construction of 21.33 m large steel multi-day trawler, ODP was maximum for steel used for construction (33.5%) followed by paints (18.2%), glass wool (13.5%), electrode (9%), FRP (8.6%), electricity (6.3%), marine plywood (3.3%), engine (2.6%), steel wire rope (2.2%), steel otterboard (1.2%), trawl winch (0.9%), propeller (0.4%), wood used for construction (0.3%) and propeller shaft (0.1%) (Fig. 4.100).

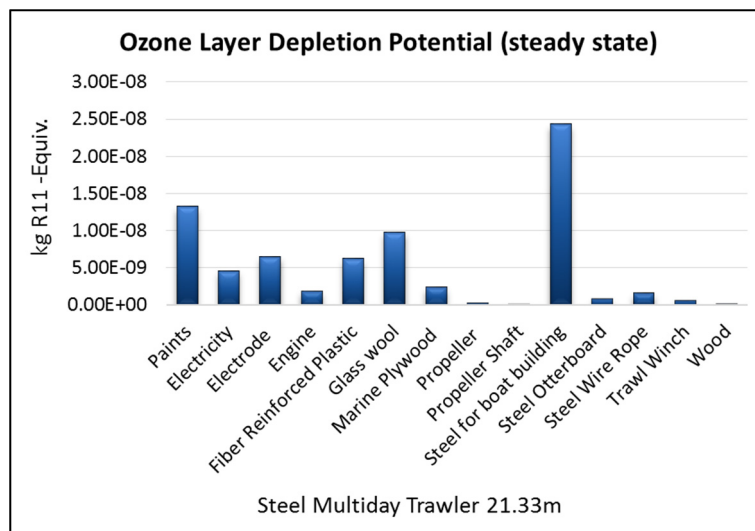

Fig. 4.100 Ozone depletion potential of 21.33 m large steel multi-day trawler

Among the materials used for construction of 22.86 m large steel multi-day trawler, ODP was maximum for steel used for construction (33.1%) followed by paints (17.8%), glass wool (14%), electrode (9.5%), FRP (8.2%), electricity (6.2%), marine plywood (3.4%), engine (2.8%), steel wire rope (2.2%), steel otterboard (1.3%), trawl winch (0.8%), propeller (0.4%), wood used for construction (0.3%) and propeller shaft (0.1%) (Fig. 4.101).

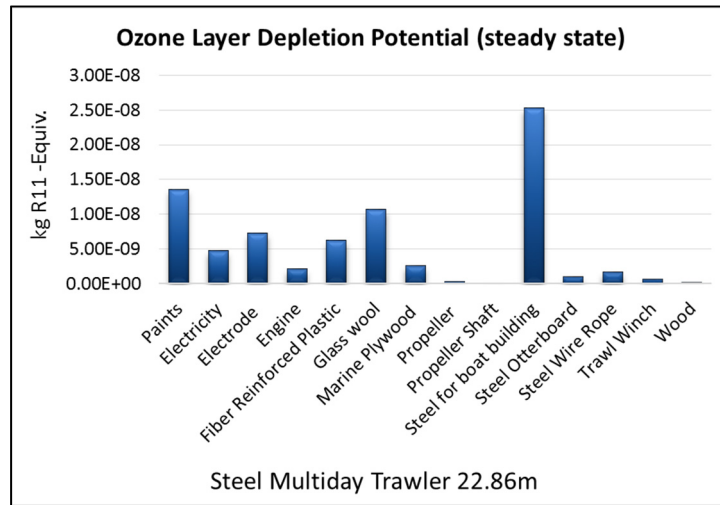

Fig. 4.101 Ozone depletion potential of 22.86 m large steel multi-day trawler

Among the materials used for construction of 24.38 m very large steel multi-day trawler, ODP was maximum for steel used for construction (32.5%) followed by paints (18.1%), glass wool (14.3%), electrode (10.1%), FRP (7.7%), electricity (6.3%), marine plywood (3.4%), engine (2.6%), steel wire rope (2.2%), steel otterboard (1.3%), trawl winch (0.8%), propeller (0.5%), wood used for construction (0.2%) and propeller shaft (0.1%) (Fig. 4.102).

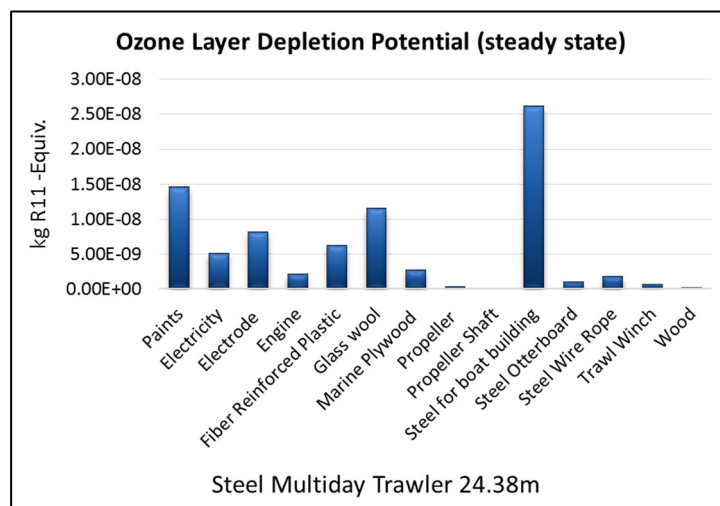

Fig. 4.102 Ozone depletion potential of 24.38 m very large steel multi-day trawler

Among the materials used for construction of 25.9 m very large steel multi-day trawler, ODP was maximum for steel used for construction (30.2%) followed by paints (16.8%), glass wool (18.3%), electrode (10.2%), FRP (7.4%), electricity (6.4%), marine plywood (3.1%), engine (2.3%), steel wire rope (2%), trawl winch (1.4%), steel otterboard (1.1%), propeller (0.5%), wood used for construction (0.3%) and propeller shaft (0.1%) (Fig. 4.103).

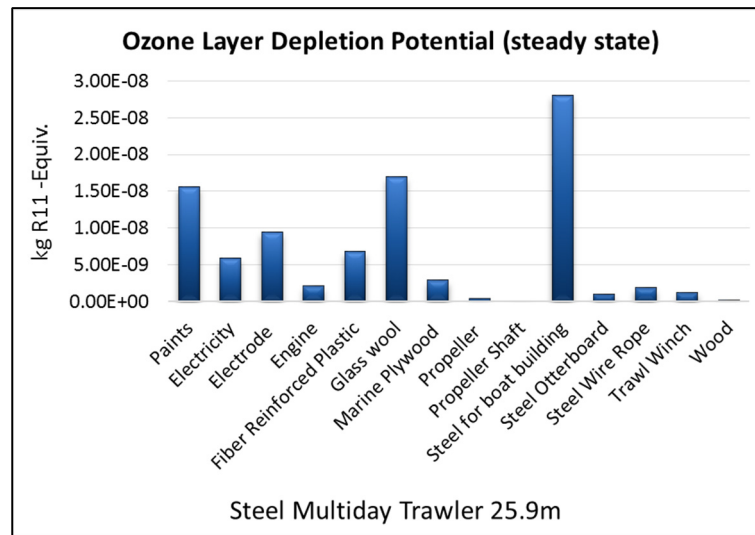

Fig. 4.103 Ozone depletion potential of 25.9 m very large steel multi-day trawler

Among the materials used for construction of 27.43 m very large steel multi-day trawler, ODP was maximum for steel used for construction (32.1%) followed by glass wool (17.3%), paints (15.9%), electrode (10.6%), FRP (7.3%), electricity (6.8%), marine plywood (3%), engine (2.1%), steel wire rope (1.9%), trawl winch (1.3%), steel otterboard (1%), propeller (0.5%), wood used for construction (0.2%) and propeller shaft (0.1%) (Fig. 4.104).

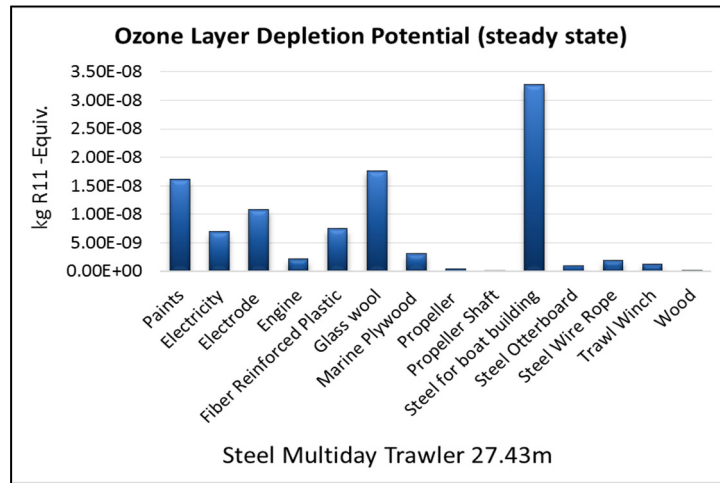

Fig. 4.104 Ozone depletion potential of 27.43 m very large steel multi-day trawler

4.3.7.7 Photochemical ozone creation potential

Among the materials used for construction of 10.66 m small wooden single-day trawler, Photochemical ozone creation potential (POCP) was maximum for wood used for construction (47.8%) followed by engine (14.7%), paints (10.6%), steel wire rope (8.8%), aluminium sheet (5.6%), trawl winch (3.7%), wooden otterboard (3.7%), marine plywood (1.8%), FRP (1.1%), electricity (0.5%), propeller shaft (0.5%), copper (0.4%), glass wool (0.3%), cotton (0.3%), steel nail (0.2%) and propeller (0.1%) (Fig. 4.105).

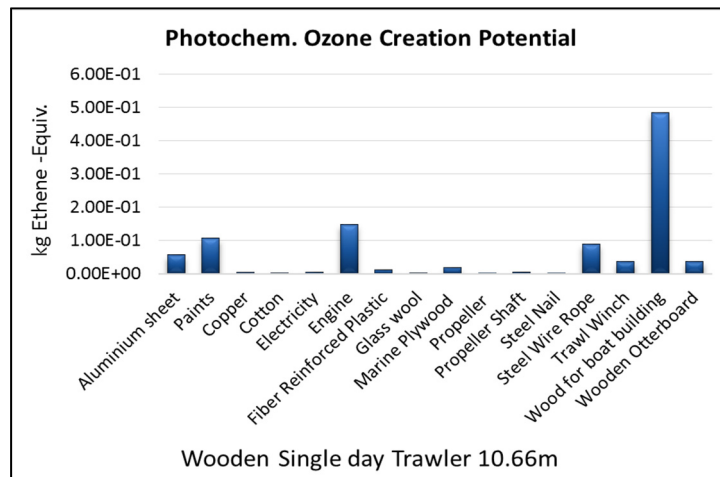

Fig. 4.105 Photochemical ozone creation potential of 10.66 m small wooden single-day trawler

Among the materials used for construction of 13.71 m medium wooden multi-day trawler, POCP was maximum for wood used for construction (50.9%) followed by engine (11.8%), paints (10.5%), steel wire rope (8.3%), aluminium sheet (6%), wooden otterboard (3.2%), trawl winch (3%), marine plywood (1.8%), FRP (1.2%), electricity (0.9%), copper (0.9%), propeller shaft (0.4%), glass wool (0.4%), cotton (0.3%), steel nail (0.3%) and propeller (0.1%) (Fig. 4.106).

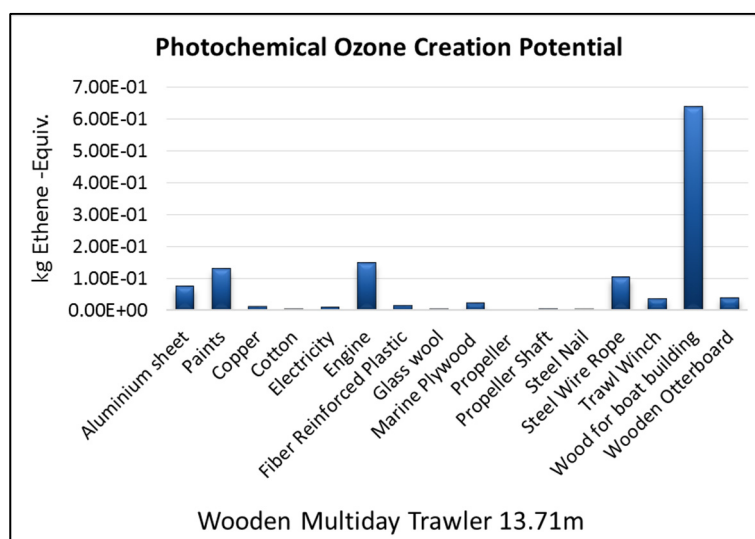

Fig. 4.106 Photochemical ozone creation potential of 13.71 m medium wooden multi-day trawler

Among the materials used for construction of 15.3 m medium wooden multi-day trawler, POCP was maximum for wood used for construction (50.4%) followed by paints (10.8%), engine (10.2%), steel wire rope (8.2%), aluminium sheet (7.2%), trawl winch (3.1%), wooden otterboard (3%), marine plywood (1.8%), copper (1.2%), FRP (1.1%), electricity (1.1%), glass wool (0.7%), propeller shaft (0.4%), cotton (0.4%), steel nail (0.4%) and propeller (0.2%) (Fig. 4.107).

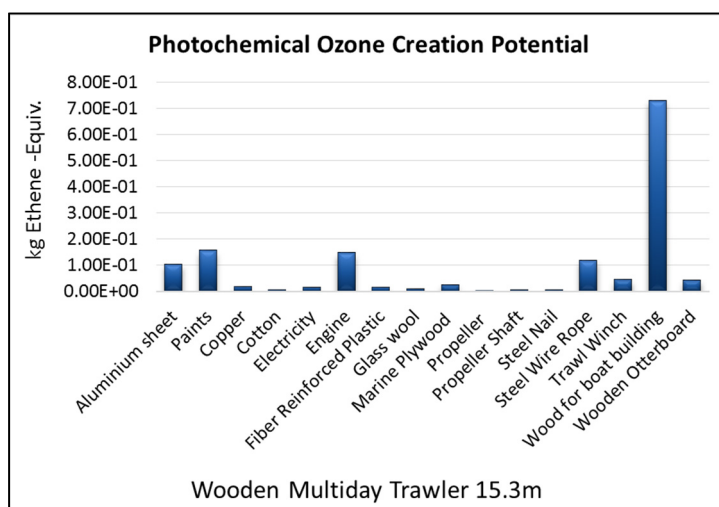

Fig. 4.107 Photochemical ozone creation potential of 15.3 m medium wooden multi-day trawler

Among the materials used for construction of 18.9 m large wooden multi-day trawler, POCP was maximum for wood used for construction (51.4%) followed by paints (10.9%), engine (8.3%), aluminium sheet (7.4%), steel wire rope (7.1%), steel otterboard (3.7%), trawl winch (3.1%), marine plywood (1.8%), copper (1.7%), electricity (1.2%), FRP (1.1%), glass wool (0.8%), cotton (0.4%), steel nail (0.4%), propeller shaft (0.3%) and propeller (0.2%) (Fig. 4.108).

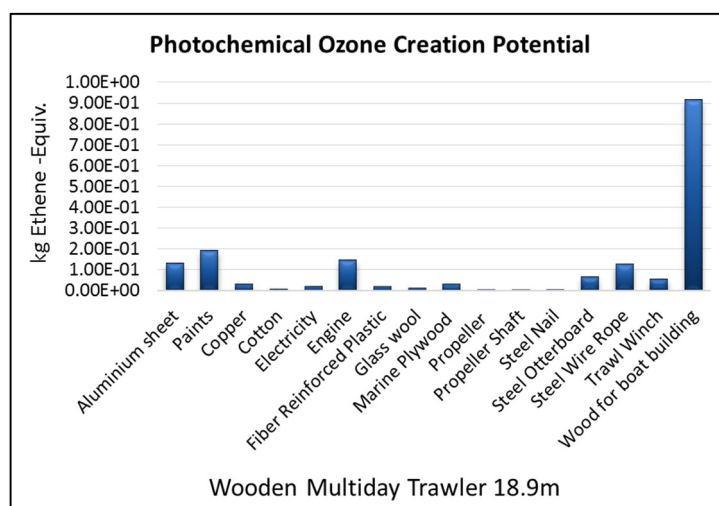

Fig. 4.108 Photochemical ozone creation potential of 18.9 m large wooden multi-day trawler

Among the materials used for construction of 19.81 m large wooden multi-day trawler, POCP was maximum for wood used for construction (51.2%) followed by paints (10.8%), engine (7.9%), aluminium sheet (7.6%), steel wire rope (7.2%), steel otterboard (3.8%), trawl winch (3%), copper (2%), marine plywood (1.8%), electricity (1.3%), FRP (1.2%), glass wool (0.8%), cotton (0.4%), steel nail (0.4%), propeller shaft (0.3%) and propeller (0.2%) (Fig. 4.109).

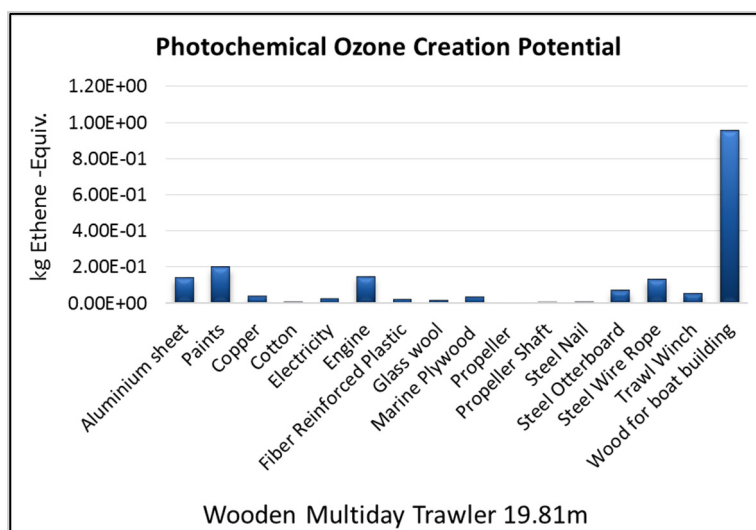

Fig. 4.109 Photochemical ozone creation potential of 19.81 m large wooden multi-day trawler

Among the materials used for construction of 21.33 m large wooden multi-day trawler, POCP was maximum for wood used for construction (51.1%) followed by paints (9.9%), aluminium sheet (9%), engine (8%), steel wire rope (6.7%), steel otterboard (3.5%), trawl winch (2.7%), copper (2.4%), marine plywood (1.7%), electricity (1.4%), FRP (1.1%), glass wool (0.8%), cotton (0.6%), steel nail (0.6%), propeller shaft (0.3%) and propeller (0.2%) (Fig. 4.110).

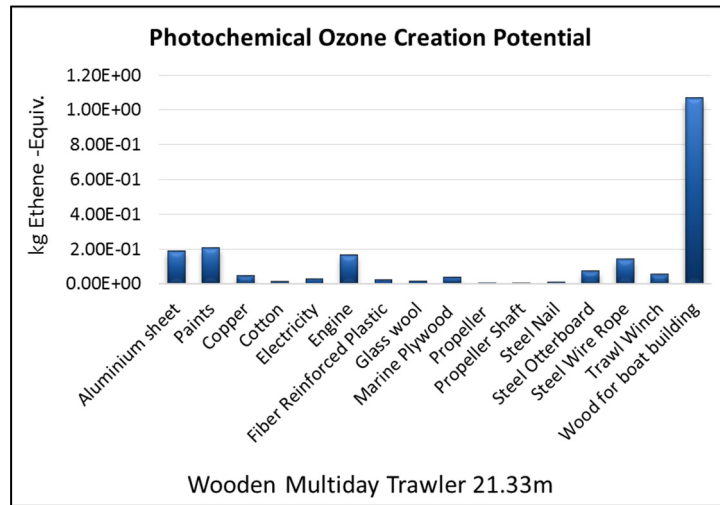

Fig. 4.110 Photochemical ozone creation potential of 21.33 m large wooden multi-day trawler

Among the materials used for construction of 13.71 m medium steel multi-day trawler, POCP was maximum for steel used for construction (59.2%) followed by wood used for construction (7.3%), engine (7.2%), paints (6.1%), electrode (5.2%), steel wire rope (5%), electricity (3.3%), steel otterboard (2.7%), trawl winch (1.8%), marine plywood (1.1%), FRP (0.5%), propeller shaft (0.3%), glass wool (0.2%) and propeller (0.1%) (Fig. 4.111).

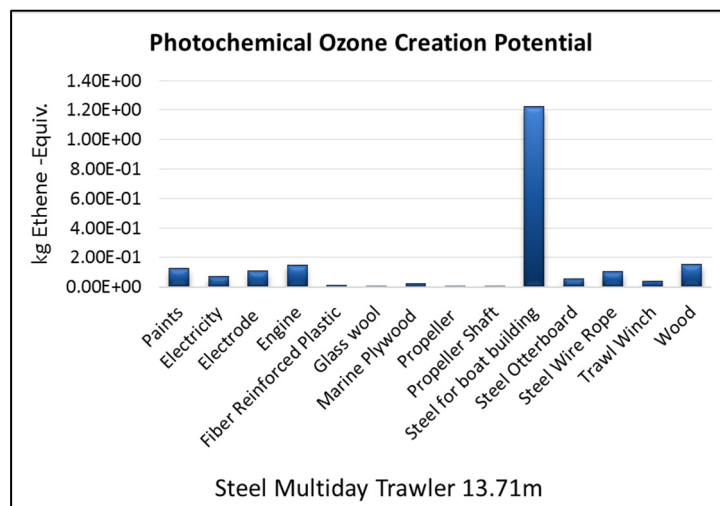

Fig. 4.111 Photochemical ozone creation potential of 13.71 m medium steel multi-day trawler

Among the materials used for construction of 15.3 m medium steel multi-day trawler, POCP was maximum for steel used for construction (60.4%) followed by wood used for construction (7.9%), paints (6.5%), engine (6.1%), steel wire rope (4.9%), electrode (4.5%), electricity (3.1%), steel otterboard (2.4%), trawl winch (1.8%), marine plywood (1.1%), FRP (0.7%), glass wool (0.4%), propeller shaft (0.2%) and propeller (0.1%) (Fig. 4.112).

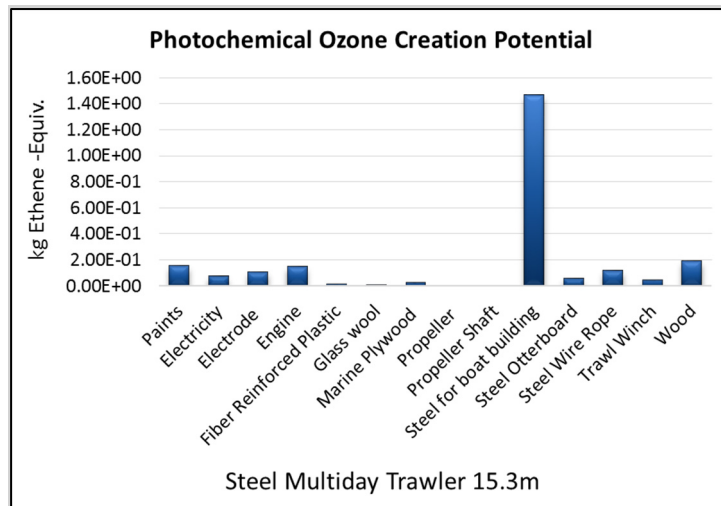

Fig. 4.112 Photochemical ozone creation potential of 15.3 m medium steel multi-day trawler

Among the materials used for construction of 18.9 m large steel multi-day trawler, POCP was maximum for steel used for construction (63.7%) followed by wood used for construction (7.5%), paints (6.7%), engine (4.8%), steel wire rope (4.1%), electrode (3.7%), electricity (2.9%), steel otterboard (2.2%), trawl winch (1.8%), marine plywood (1.0%), FRP (0.7%), glass wool (0.5%), propeller shaft (0.2%) and propeller (0.1%) (Fig. 4.113).

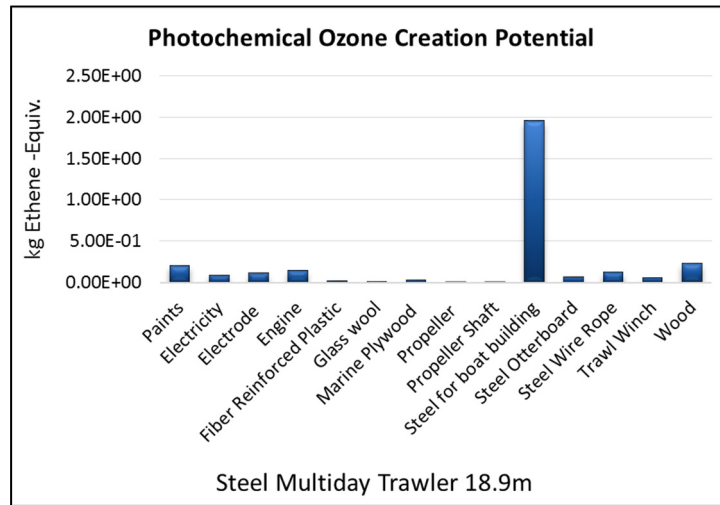

Fig. 4.113 Photochemical ozone creation potential of 18.9 m large steel multi-day trawler

Among the materials used for construction of 19.81 m large steel multi-day trawler, POCP was maximum for steel used for construction (64.1%) followed by wood used for construction (7.2%), paints (6.6%), engine (4.7%), steel wire rope (4.2%), electrode (3.9%), electricity (2.9%), steel otterboard (2.2%), trawl winch (1.7%), marine plywood (1.1%), FRP (0.7%), glass wool (0.5%), propeller shaft (0.2%) and propeller (0.1%) (Fig. 4.114).

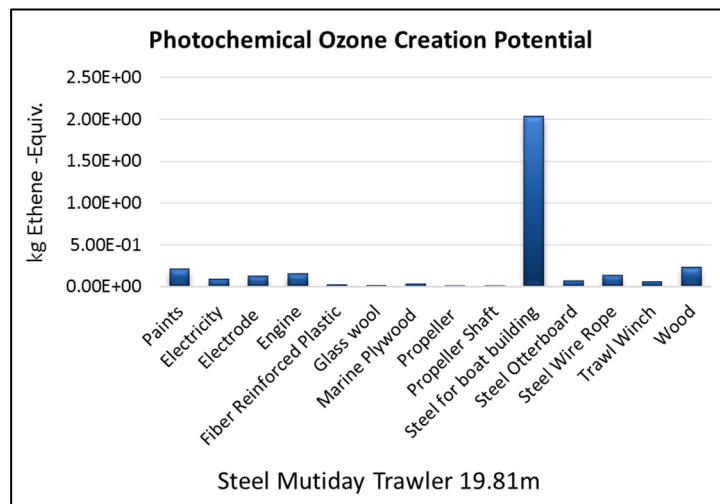

Fig. 4.114 Photochemical ozone creation potential of 19.81 m large steel multi-day trawler

Among the materials used for construction of 21.33 m large steel multi-day trawler, POCP was maximum for steel used for construction (64.0%) followed by wood used for construction (6.9%), paints (6.5%), engine (5.0%), steel wire rope (4.2%), electrode (4.2%), electricity (2.8%), steel otterboard (2.2%), trawl winch (1.7%), marine plywood (1.1%), FRP (0.7%), glass wool (0.5%), propeller shaft (0.2%) and propeller (0.1%) (Fig. 4.115).

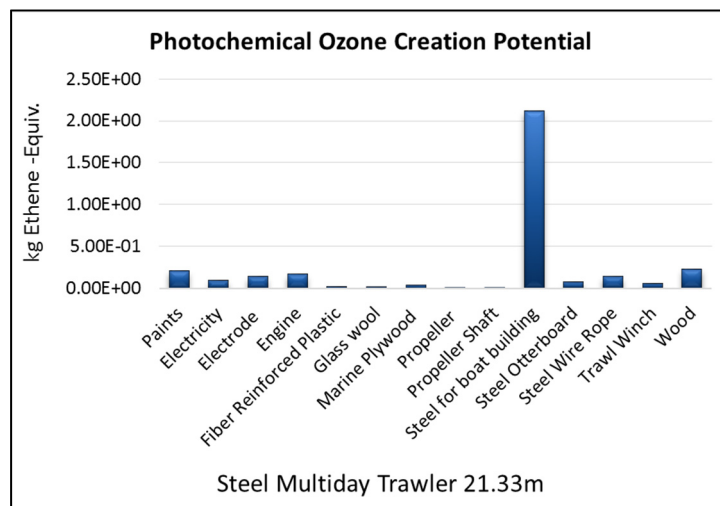

Fig. 4.115 Photochemical ozone creation potential of 21.33 m large steel multi-day trawler

Among the materials used for construction of 22.86 m large steel multi-day trawler, POCP was maximum for steel used for construction (63.5%) followed by wood used for construction (6.6%), paints (6.2%), engine (5.3%), electrode (4.4%), steel wire rope (4.3%), electricity (2.8%), steel otterboard (2.6%), trawl winch (1.6%), marine plywood (1.1%), FRP (0.7%), glass wool (0.5%), propeller shaft (0.2%) and propeller (0.1%) (Fig. 4.116).

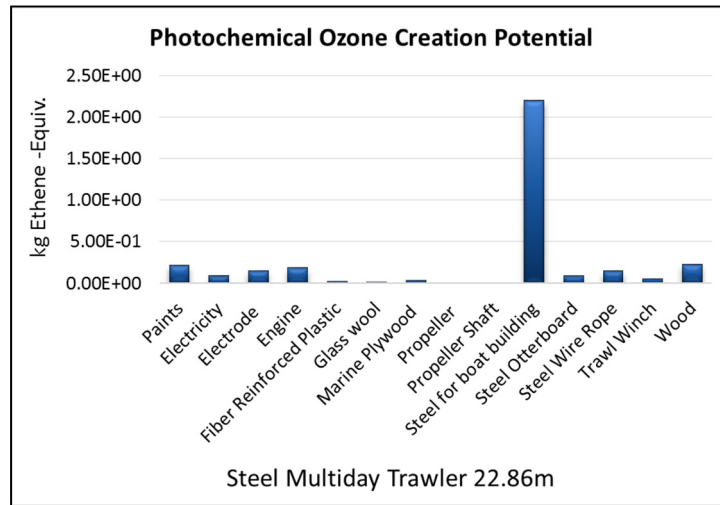

Fig. 4.116 Photochemical ozone creation potential of 22.86 m large steel multi-day trawler

Among the materials used for construction of 24.38 m very large steel multi-day trawler, POCP was maximum for steel used for construction (63.4%) followed by paints (6.5%), wood used for construction (6.4%), engine (5.1%), electrode (4.8%), steel wire rope (4.3%), electricity (2.9%), steel otterboard (2.5%), trawl winch (1.5%), marine plywood (1.1%), FRP (0.6%), glass wool (0.5%), propeller shaft (0.2%) and propeller (0.1%) (Fig. 4.117).

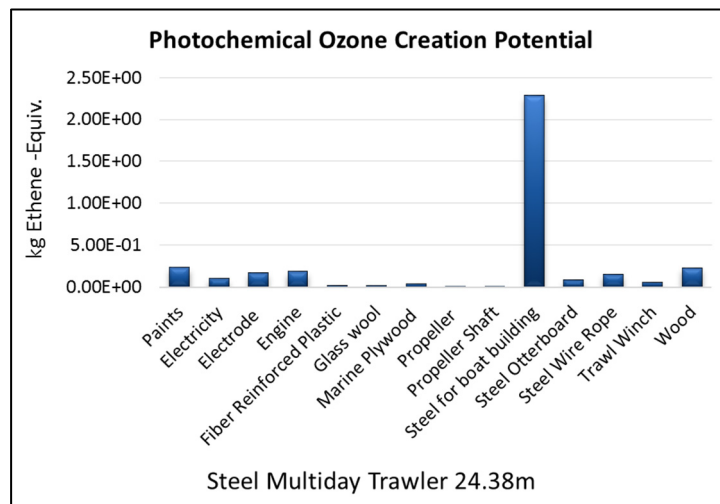

Fig. 4.117 Photochemical ozone creation potential of 24.38 m very large steel multi-day trawler

Among the materials used for construction of 25.9 m very large steel multi-day trawler, POCP was maximum for steel used for construction (61.5%) followed by wood used for construction (7.5%), paints (6.3%), electrode (5.0%), engine (4.7%), steel wire rope (4.1%), electricity (3.0%), trawl winch (2.8%), steel otterboard (2.2%), marine plywood (1.1%), glass wool (0.7%), FRP (0.6%), propeller shaft (0.2%) and propeller (0.1%) (Fig. 4.118).

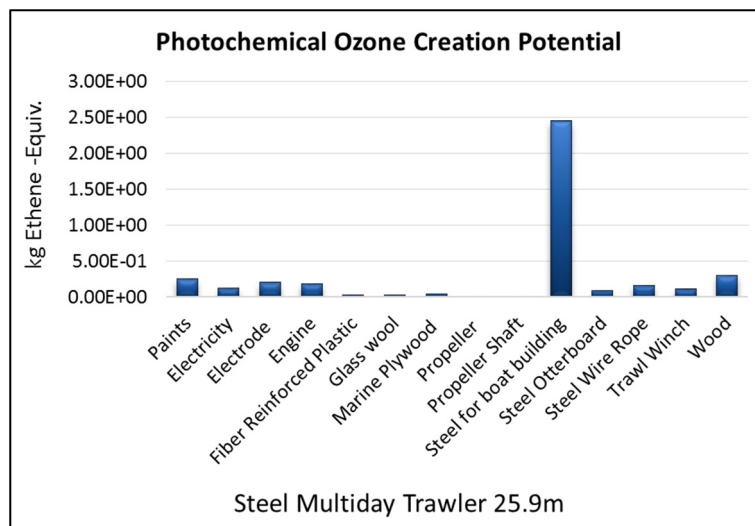

Fig. 4.118 Photochemical ozone creation potential of 25.9 m very large steel multi-day trawler

Among the materials used for construction of 27.43 m very large steel multi-day trawler, POCP was maximum for steel used for construction (64.7%) followed by wood used for construction (5.8%), paints (5.8%), electrode (5.2%), engine (4.2%), steel wire rope (3.9%), electricity (3.2%), trawl winch (2.5%), steel otterboard (2.0%), marine plywood (1.0%), glass wool (0.7%), FRP (0.6%), propeller shaft (0.2%) and propeller (0.1%) (Fig. 4.119).

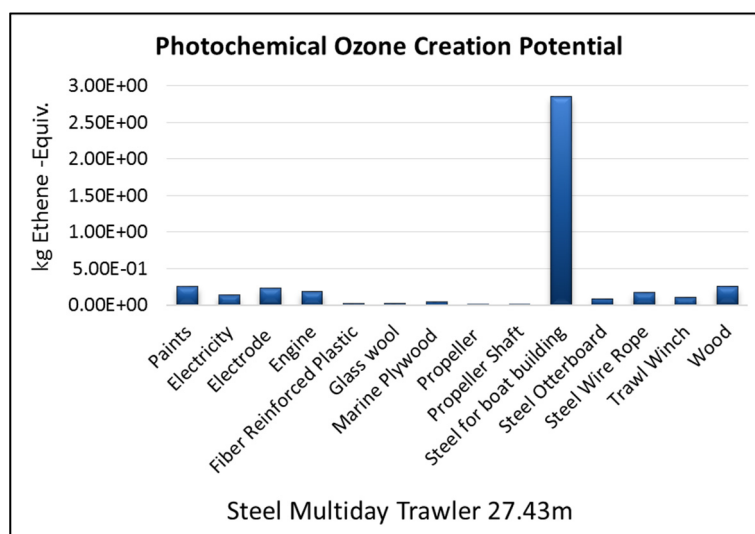

Fig. 4.119 Photochemical ozone creation potential of 27.43 m very large steel multi-day trawler

4.4 Discussion

As material and energy inputs to vessel construction and maintenance have previously been found to make relatively small contributions to the environmental impacts of seafood products (Hayman *et al.*, 2000; Huse *et al.*, 2002), most of the studies have not taken detailed information on this aspect (Hospido and Tyedmers, 2005). A comparison of Global warming potential from different categories of trawlers is given in Fig. 4.120 and Table 4.5. Global warming potential ranged from -2165 to -4328 kg CO₂ Equiv. in wooden trawlers and from 2824 to 6648 kg CO₂ Equiv. in steel trawlers depending on the size. The GWP was higher in very large steel trawlers due to the inorganic emissions to air especially CO₂. In the case of 27.43 m very large steel multi-day trawler, the GWP was higher due to the inorganic emissions to air especially CO₂ (8.19E003 kg CO₂). The global warming potential has negative value for renewable resources (-2.71E003 kg CO₂). 86.4% CO₂ were from steel used for construction especially from hull.

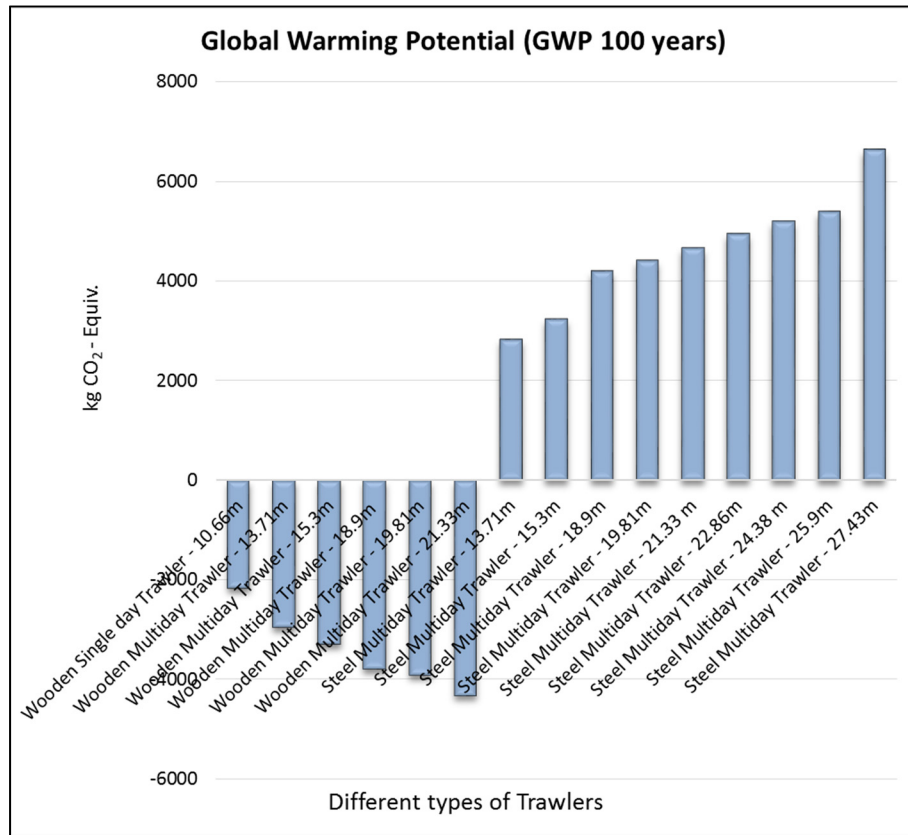

Fig. 4.120 Global warming potential from different trawlers

Table 4.5: Comparison of global warming potential from different trawlers

Type of vessel	L _{OA} (m)	Global Warming Potential (GWP 100 years) [kg CO ₂ Equiv.]
Wooden trawlers		
Small wooden single-day trawlers	< 12	-2165
Medium wooden multi-day trawlers	12-16	-2953 - -3297
Large wooden multi-day trawlers	16-24	-3781 - -4328
Steel trawlers		
Medium steel multi-day trawlers	12-16	2824 - 3245
Large steel multi-day trawlers	16-24	4206 - 4956
Very large steel multi-day trawlers	> 24	5202 - 6648

A comparison of Abiotic depletion potential (fossil) (ADP-fossil) from different categories of trawlers is furnished in Fig. 4.121 and Table 4.6. Abiotic depletion potential ranged from 14236 MJ in small wooden single-day trawlers (<12 m L_{OA}) to 99088 MJ in very large multi-day steel trawlers of 27.43 m L_{OA}. ADP- fossil was higher in steel trawlers due to the non-renewable energy resources especially hard coal (resource) and crude oil (resource). In the case of 27.43 m very large steel multi-day trawler, the ADP-fossil was higher due to the non-renewable energy resources especially hard coal (resource) 82% and crude oil (resource) 12.5%. 61.6% hard coal (resource) were from steel used for construction (especially from hull) and 4.27% crude oil (resource) were from use of electrode.

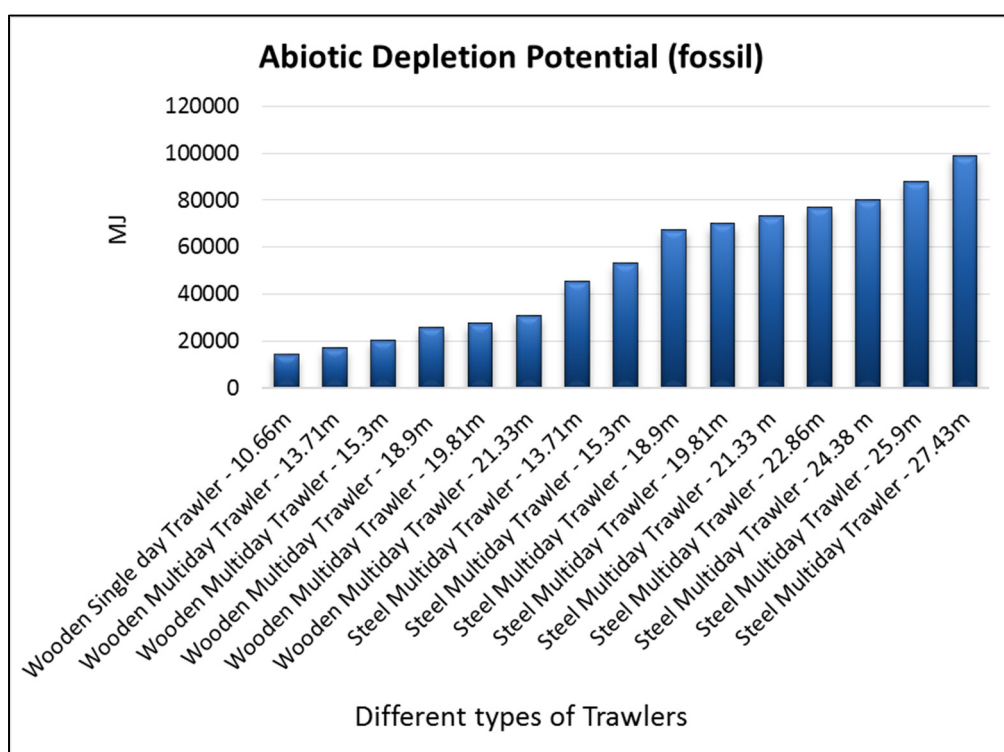

Fig. 4.121 Abiotic depletion potential (fossil) from different trawlers

Table 4.6: Comparison of abiotic depletion potential (fossil) from different trawlers

Type of vessel	LOA (m)	Abiotic Depletion Potential (fossil) [MJ]
Wooden trawlers		
Small wooden single-day trawlers	< 12	14236
Medium wooden multi-day trawlers	12-16	17231 - 20460
Large wooden multi-day trawlers	16-24	25923 - 30861
Steel trawlers		
Medium steel multi-day trawlers	12-16	45399 - 53389
Large steel multi-day trawlers	16-24	67471 - 76824
Very large steel multi-day trawlers	> 24	80199 - 99088

Acidification potential (AP) from different categories of trawlers are compared in Fig. 4.122 and Table 4.7. AP ranged from 5.62 kg SO₂ Equiv. in small wooden single-day trawlers (<12 m L_{OA}) to 43.13 kg SO₂ Equiv. in very large multi-day steel trawlers of 27.43 m L_{OA}. The Acidification potential was higher in steel trawlers due to the inorganic emissions to air especially Sulphur dioxide and Nitrogen oxides which is mostly derived from steel. In the case of 27.43 m very large steel multi-day trawler, AP was higher due to the inorganic emissions to air especially Sulphur dioxide (71.7%) and Nitrogen oxides (20.8%) which is mostly derived from steel especially hull.

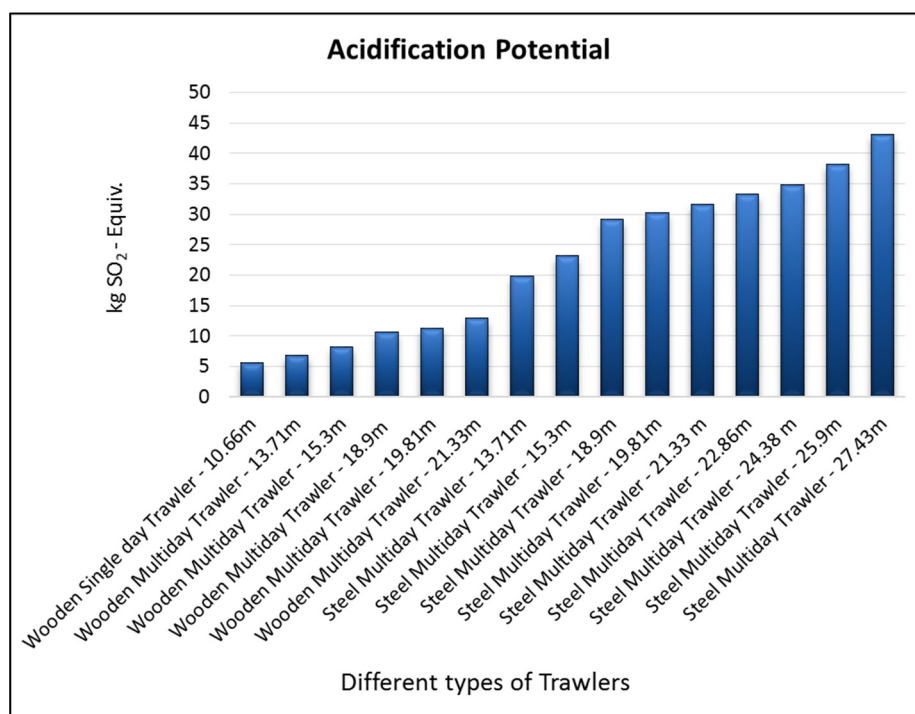

Fig. 4.122 Acidification potential from different trawlers

Table 4.7: Comparison of acidification potential from different trawlers

Type of vessel	L _{OA} (m)	Acidification Potential [kg SO ₂ Equiv.]
Wooden trawlers		
Small wooden single-day trawlers	< 12	5.62
Medium wooden multi-day trawlers	12-16	6.87 - 8.26
Large wooden multi-day trawlers	16-24	10.64 - 12.89
Steel trawlers		
Medium steel multi-day trawlers	12-16	19.89 - 23.19
Large steel multi-day trawlers	16-24	29.17 - 33.27
Very large steel multi-day trawlers	> 24	34.81 - 43.13

Eutrophication potential (EP) from different categories of trawlers are represented in Fig. 4.123 and Table 4.8. EP ranged from 0.43 kg Phosphate Equiv. in small wooden single-day trawlers to 2.66 kg Phosphate Equiv. in very

large steel trawlers. EP was high in steel trawlers due to the inorganic emissions to air especially Nitrogen oxides mostly derived from steel. In the case of 27.43 m steel multi-day trawler, EP was higher due to the inorganic emissions to air especially Nitrogen oxides (87.7%) which is mostly derived from steel hull.

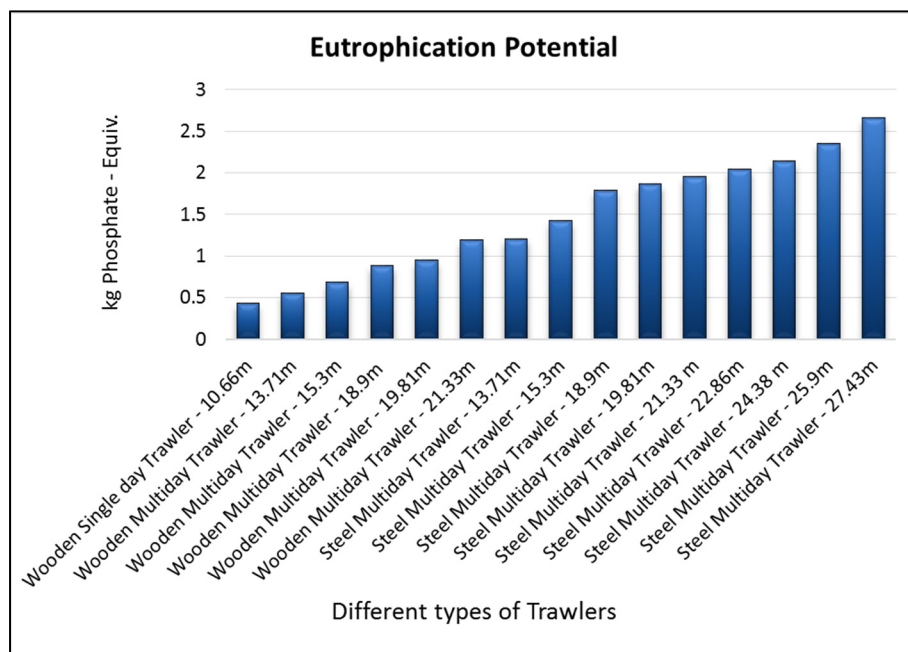

Fig. 4.123 Eutrophication potential from different trawlers

Table 4.8: Comparison of eutrophication potential from different trawlers

Type of vessel	LoA (m)	Eutrophication Potential [kg Phosphate Equiv.]
Wooden trawlers		
Small wooden single-day trawlers	< 12	0.43
Medium wooden multi-day trawlers	12-16	0.56 - 0.68
Large wooden multi-day trawlers	16-24	0.89 - 1.19
Steel trawlers		
Medium steel multi-day trawlers	12-16	1.21 - 1.42
Large steel multi-day trawlers	16-24	1.79 - 2.05
Very large steel multi-day trawlers	> 24	2.14 - 2.66

A comparison of Marine aquatic ecotoxicity potential (MAETP) from different categories of trawlers is represented in Fig. 4.124 and Table 4.9. MAETP varied from $6.51E+05$ kg DCB Equiv. in small wooden trawlers to $3.26E+06$ kg DCB Equiv. in very large steel trawlers. MAETP was higher in steel trawlers due to the inorganic emissions to air especially Hydrogen fluoride which is mostly derived from steel and electricity. In the case of 27.43 m steel multi-day trawler, the MAETP was higher due to the inorganic emissions to air especially Hydrogen fluoride (96.4%) which is mostly derived from steel and electricity.

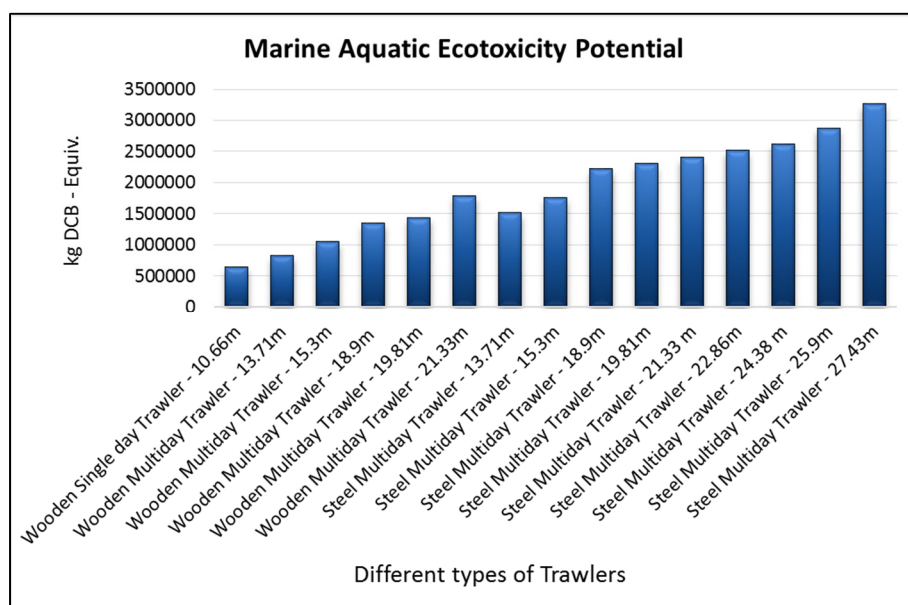

Fig. 4.124 Marine aquatic ecotoxicity potential from different trawlers

Table 4.9: Comparison of marine aquatic ecotoxicity potential from different trawlers

Type of vessel	L _{OA} (m)	Marine Aquatic Ecotoxicity Potential [kg DCB Equiv.]
Wooden trawlers		
Small wooden single-day trawlers	< 12	6.51E+05
Medium wooden multi-day trawlers	12-16	8.28E+05 - 1.05E+06
Large wooden multi-day trawlers	16-24	1.35E+06 - 1.79E+06
Steel trawlers		
Medium steel multi-day trawlers	12-16	1.52E+06 - 1.76E+06
Large steel multi-day trawlers	16-24	2.22E+06 - 2.52E+06
Very large steel multi-day trawlers	> 24	2.63E+06 - 3.26E+06

A comparison of Ozone depletion potential (ODP) from different categories of trawlers are presented in Fig. 4.125 and Table 4.10. ODP varied from 2.17E-07 to 1.77E-06 kg R11 Equiv. in wooden trawlers and from 4.22E-08 to 1.02E-07 kg R11 Equiv. in steel trawlers, depending on the size of trawlers. ODP was higher in wooden trawlers due to the halogenated organic emissions into the air especially R114 (dichlorotetrafluoroethane) and R11 (trichlorofluoromethane) which is mostly derived from copper nails and aluminium sheet, used in wooden boat construction. In the case of 21.33 m wooden multi-day trawler, ODP was higher due to the halogenated organic emissions into the air especially R114 (dichlorotetrafluoroethane) (52.8%) and R11 (trichlorofluoromethane) (34.8%) which is mostly derived from copper nails and aluminium sheet.

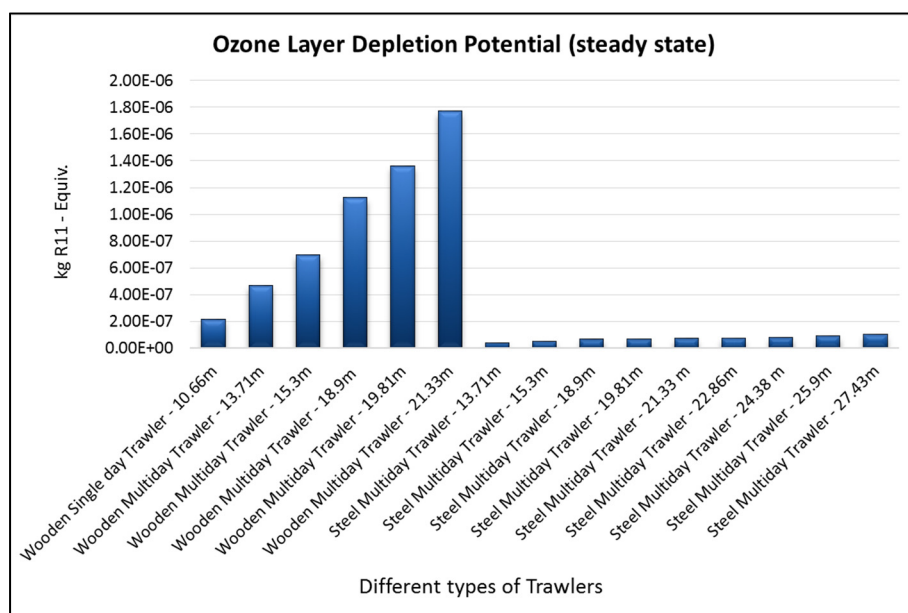

Fig. 4.125 Ozone depletion potential from different trawlers

Table 4.10: Comparison of ozone depletion potential from different trawlers

Type of vessel	LoA (m)	Ozone Layer Depletion Potential [kg R11 Equiv.]
Wooden trawlers		
Small wooden single-day trawlers	< 12	2.17E-07
Medium wooden multi-day trawlers	12-16	4.72E-07 - 6.99E-07
Large wooden multi-day trawlers	16-24	1.13E-06 - 1.77E-06
Steel trawlers		
Medium steel multi-day trawlers	12-16	4.22E-08 - 5.26E-08
Large steel multi-day trawlers	16-24	6.69E-08 - 7.64E-08
Very large steel multi-day trawlers	> 24	8.07E-08 - 1.02E-07

A comparison of Photochemical ozone creation potential (POCP) from different categories of trawlers are furnished in Fig. 4.126 and Table 4.11. POCP ranged from 1.00 to 2.09 kg Ethene Equiv. in wooden trawlers and from 2.06 to 4.41 kg Ethene Equiv. in steel trawlers, depending on the size of trawlers. Photochemical Ozone Creation Potential was higher in steel trawlers due to the inorganic emissions to air especially Carbon monoxide, Sulphur

dioxide, Nitrogen oxides mostly derived from steel. In the case of 27.43 m steel multi-day trawler, POCP was higher due to the inorganic emissions to air especially Carbon monoxide (46.3%), Sulphur dioxide (28%), Nitrogen oxides (11.4%) mostly derived from steel and organic emissions especially group NMVOC to air (14.4%) which is mostly derived from wood.

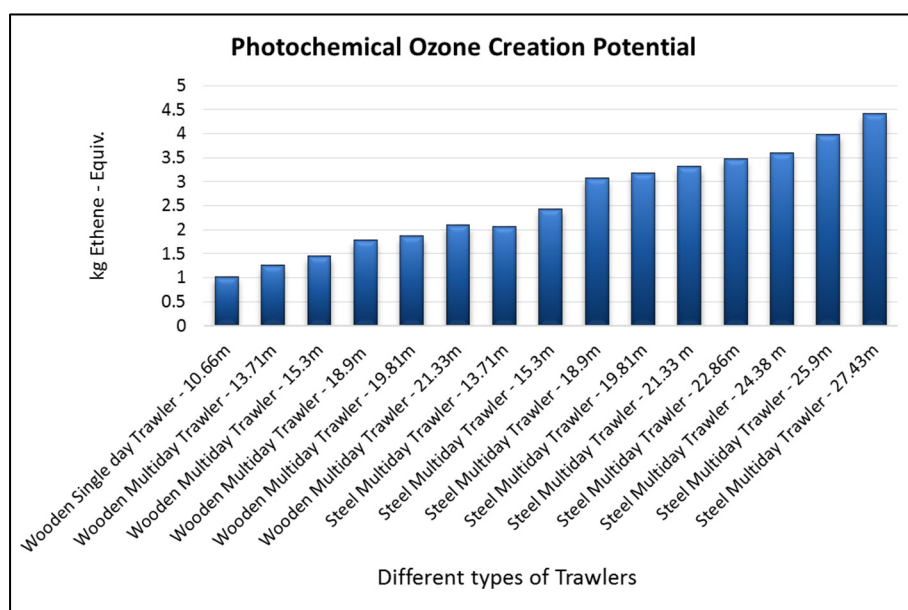

Fig. 4.126 Photochemical ozone creation potential from different trawlers

Table 4.11: Comparison of photochemical ozone creation potential from different trawlers

Type of vessel	LoA (m)	Photochemical Ozone Creation Potential [kg Ethene Equiv.]
Wooden trawlers		
Small wooden single-day trawlers	< 12	1.00
Medium wooden multi-day trawlers	12-16	1.25 - 1.45
Large wooden multi-day trawlers	16-24	1.78 - 2.09
Steel trawlers		
Medium steel multi-day trawlers	12-16	2.06 - 2.43
Large steel multi-day trawlers	16-24	3.07 - 3.46
Very large steel multi-day trawlers	> 24	3.60 - 4.41

4.5 Conclusion

There is variation in design and size of trawlers which affects the material consumption and energy use in the construction of trawlers and affecting the impact category values. The Global warming potential was higher in very large steel multi-day trawlers due to the inorganic emissions to air especially CO₂. The Abiotic depletion fossil was higher in steel trawlers especially very large types due to the non-renewable energy resources namely hard coal (resource) and crude oil (resource). The Acidification potential was higher in steel trawlers due to the inorganic emissions to air especially Sulphur dioxide and Nitrogen oxides which is mostly derived from steel. The Eutrophication potential was high in steel trawlers due to the inorganic emissions to air especially Nitrogen oxides mostly derived from steel. The Marine aquatic ecotoxicity potential was higher in steel trawlers due to the inorganic emissions to air especially Hydrogen fluoride which is mostly derived from steel and electricity. Ozone depletion potential was higher in wooden trawlers due to the halogenated organic emissions into the air especially R114 (dichlorotetrafluoroethane) and R11 (trichlorofluoromethane) which is mostly derived from copper nails and aluminium sheet, used in wooden boat construction. Photochemical ozone creation potential was higher in steel trawlers due to the inorganic emissions to air especially Carbon monoxide, Sulphur dioxide, Nitrogen oxides mostly derived from steel.

.....*SCS*.....

LIFE CYCLE ASSESSMENT AND CARBON FOOTPRINT OF TRAWL GEAR SYSTEMS

5.1 Introduction

Trawls are towed gears consisting of funnel shaped body of netting having extended sides to form wings in the front and closed by a codend at the distal end (Nedlec, 1982). Trawls are operated from surface to bottom for a wide variety of crustaceans, cephalopods, elasmobranchs and finfishes, in different parts of the world. Classification of trawls in India is given in Fig. 5.1.

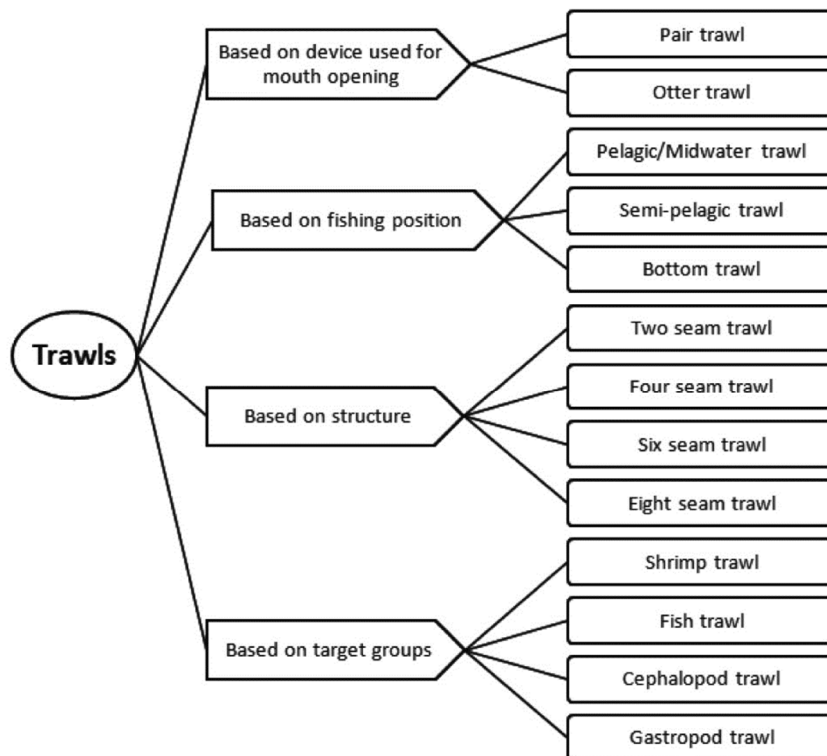

Fig. 5.1 Classification of trawls

According to the depth of operation, there are pelagic/midwater trawls, semi pelagic trawls and bottom trawls. Depending on the number of panels, there are two seam, four seam, six seam and eight seam trawls. Based on the target species, there are shrimp trawls, fish trawls, cephalopod trawls and gastropod trawls.

Structure of a typical trawl net is given in Fig. 5.2.

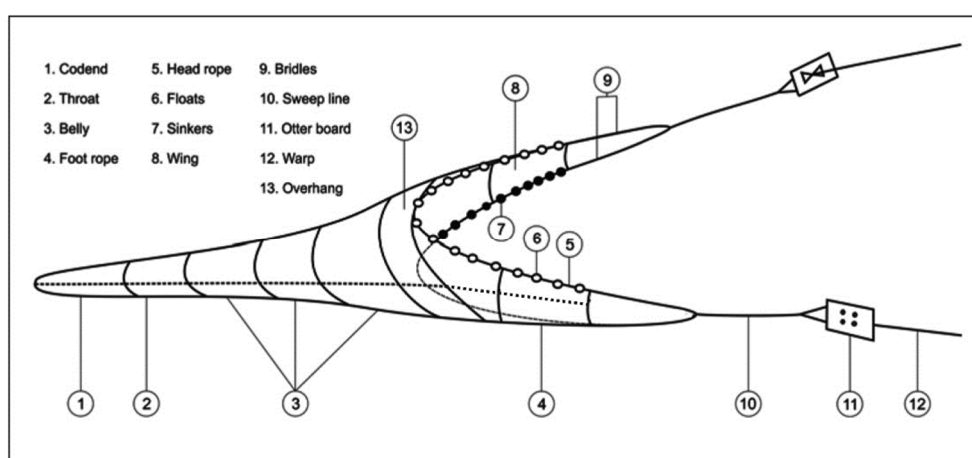

Fig. 5.2 Structure of a typical trawl net

Midwater trawls have been introduced in the commercial fisheries of some countries since the Second World War for exploiting fish concentrations in the water layers away from the seabed (Parrish, 1975). Firstly it was aimed to move the trawl gear just above sea bottom. Later, the bottom trawls were used to be towed in the mid water layers by being suspended from the surface with the help of floats. Each panel is constructed of different sections of suitably shaped netting of the required twine and mesh size specifications in order to impart the required shape and trim to the trawl when in operation (Pravin, 2001; Sreedhar *et al.*, 2002; Rajeswari *et al.*, 2012). Top and bottom panels are attached to the head rope and the foot rope, respectively. Floats

along the head rope and weighted foot rope keeps the net mouth vertically open during operations (Thomas, 2009).

Trawl nets are conical bag nets with two wings and a codend where catch is concentrated, operated by towing from one or two boats. The wings prevent the fish in front of approaching trawl from escaping. The design and size of the trawl net and accessories have changed considerably in recent years.

5.2 Materials and methods

The detailed design details of commonly used trawl nets along Kerala coast, *viz.*, fish trawls, cephalopod trawls and shrimp trawls were collected for the analysis. Details of life cycle assessment and carbon footprint analysis are given in chapter 2. In this chapter, LCA of trawl nets coming under different categories based on the target groups caught are considered. GaBi-6 software (PE International, Leinfelden-Echterdingen) was used for Life Cycle Assessment (LCA) and Carbon Footprint analysis. Seven important parameters *viz.* Global warming potential, Abiotic depletion potential (fossil), Acidification potential, Eutrophication potential, Marine aquatic ecotoxicity potential, Ozone depletion potential and Photochemical ozone creation potential were considered in this study.

Material and energy inputs to trawl net construction and maintenance and their contributions to the environmental impacts have been analysed in this chapter to quantify impacts associated with the use of HDPE webbing, floats, polypropylene rope, lead sinkers and iron sinkers (Fig. 5.3). 15 different types of trawl nets *viz.*, 39.6 m fish trawl, 53.8 m fish trawl, 72.0 m fish trawl, 76.5 m fish trawl, 81.0 m fish trawl, 85.6 m fish trawl, 33.4 m cephalopod trawl, 45.6 m cephalopod trawl, 54.0 m cephalopod trawl, 57.6 m cephalopod trawl, 34.2 m

shrimp trawl, 39.6 m shrimp trawl, 40.0 m shrimp trawl, 51.0 m shrimp trawl and 58.0 m shrimp trawl were considered for the study.

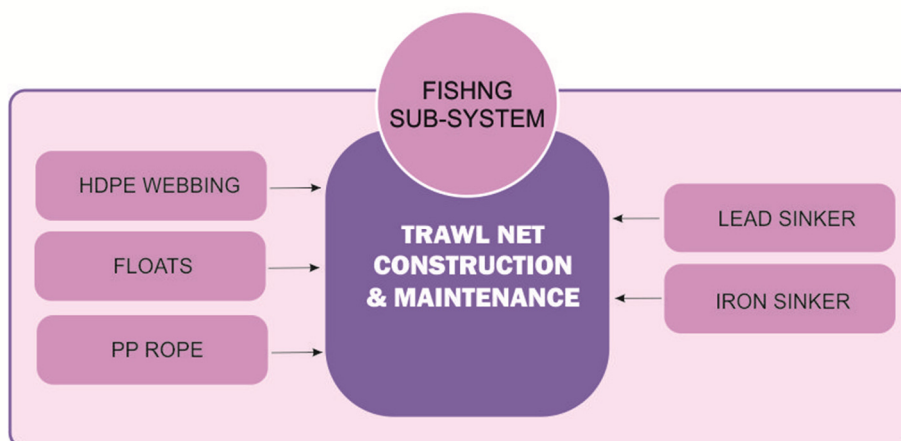

Fig. 5.3 Material inputs to trawl net construction and maintenance

Data on design details and rigging of trawl nets were obtained through field survey. The gear designs were documented following FAO conventions (FAO, 1975; 1978; Nedlec, 1982). Sources of material inputs to gear manufacture were estimated from design drawings. Netting requirements were estimated as per method described by Hameed & Boopendranath (2000) and elaborated in chapter 2.

Useful life-time of HDPE webbing materials, polypropylene ropes and iron sinkers for trawls estimated for amortisation purposes were 1 year. Service life of lead sinkers were estimated as 2 years and 6 months and that of HDPE floats as 9 months.

5.3 Results

This Chapter focuses on Fishing Sub-system 2, with trawl net as functional unit.

5.3.1 Trawl nets

Trawl nets operated along the entire coast of Kerala are mostly two seam designs. Changes are often made, only to the size of the head rope and meshes depending on the target group, but the two seam trawl continues to be the favoured design used for fast swimming and off-bottom species also. Based on the target groups for which the nets are used, trawl nets of Kerala can be classified into three, *viz.*, fish trawls; shrimp trawls and cephalopod trawls (Table 5.1). The head rope length of trawls being used varied from 33 to 86 m. Trawl nets are fabricated by the net makers using machine made high density polyethylene (HDPE) netting of varying mesh sizes. The diameter of HDPE twisted monofilament used varies from 0.5 to 3 mm. Net panels used for fabrication are prepared by cutting and shaping as per the design and later the panels are laced together to make the characteristic bag shape of the trawl net. PP ropes of 10-16 mm are used as head rope and foot rope and the net is mounted to these ropes, according to the required hanging ratio. Codend with mesh size ranging from 18 to 25 mm are most commonly used. The shape of the trawl while being towed in water is determined by the forces acting on it such as drag, floatation and weight. Drag is mainly contributed by the surface area of the netting twine, floats, sinkers and shape of the net and it changes as a function of the towing speed (Wileman, 1984; Seafish *et al.*, 1993). Scenes of the construction of a trawl net at Munambam and measurement of design details of a trawl net at Kasaragod are given in Fig. 5.4 and 5.5, respectively.

Table 5.1: Size ranges of trawl nets based on target groups

Different types of trawl nets	Head rope length (m)
Fish trawl	39.6 - 85.6
Cephalopod trawl	33.4 - 57.6
Shrimp trawl	34.2 - 58.0



Fig. 5.4 Construction of a trawl net at Munambam



Fig. 5.5 Measurement of design details of a trawl net at Kasaragod

5.3.1.1 Fish trawls

The dwindling shrimp resources and the need to capture fast moving, off-bottom resources, led to the adoption of trawl designs with large meshes in the wing regions for reduction in drag and to gain more vertical height. Availability of imported engines from China with very high engine power led to the proliferation of trawl designs to capture fish resources (Pravin *et al.*, 2012). These large mesh trawls are operated slightly off-bottom with a towing speed of more than 2.5 kn. Fish trawls currently operated in Kerala are of two types, *viz.*, two-seam trawls and four-seam trawls, of which the former is more popular. Two seam trawls used are with or without an overhang section. Fish trawls mainly target finfishes like perches, lizardfishes, croakers, silver bellies, elasmobranchs, pomfrets, big-jawed jumper, catfishes, eels, goatfishes, threadfins, clupeoids, mackerels, carangids and ribbonfishes. The head rope length of fish trawls varies from 39.6 to 85.6 m (Table 5.1) and polypropylene ropes of 12 to 16 mm diameter are commonly used. The fish trawls are made of HDPE netting with twine diameter varying from 0.5 to 3 mm. The mesh size of the wing section varied from 60 to 5000 mm depending on the type of trawl and region of operation. In some cases, a codend cover made of 4 mm diameter HDPE or PP netting is provided for protection. The floats used are in sizes ranging from 76 to 356 mm diameter and shapes are either spherical, cylindrical or oval. The total weight of sinkers in the foot rope varies from 30 to 70 kg depending on the size of the net and operational requirements. The sinkers used are made of lead weighing 100-250 g each or iron chain. The head rope length is usually increased to achieve greater mouth opening during operation. Introduction of large meshes, sometimes upto 5000 mm in case of ribbonfish trawls in the fore parts, is intended to reduce the drag of the net and increase the speed of towing. Design details of different fish trawls are given in Fig. 5.6 to 5.11.

5.3.1.2 Cephalopod trawls

Two seam trawls with head rope length varying from 33.4 to 57.6 m are used for capturing cephalopods (Table 5.1). Polypropylene ropes with

diameter 12-14 mm are used as head rope and foot rope. Mesh sizes commonly used varied from 1200 to 18 mm from the wings to the codend and the diameter of twine used ranges from 1.25-2.5 mm. The majority of the trawlers use 'V' form steel otterboards for deploying cephalopod trawls. Design details of cephalopod trawls are given in Fig. 5.12 to 5.15.

5.3.1.3 Shrimp trawls

The majority of the shrimp trawls operated are of two seam design and a few are four seam. The head rope length of shrimp trawls varied from 34.2 to 58.0 m (Table 5.1). Polypropylene ropes of 10 to 16 mm diameter are used as head rope and foot rope. The twine sizes of netting ranged from 0.5 to 1.25 mm and mesh sizes ranged from 40 to 300 mm and 18 - 25 mm for codend. 'V' form steel otter boards and wooden flat rectangular otter boards are used in shrimp trawling of which 'V' form otterboards are predominantly used. Design details of different shrimp trawls in use along Kerala coast are given in Fig. 5.16 to 5.20.

Floats

Floats are attached to the head rope at intervals to lift the same to achieve maximum vertical opening of the net mouth. The number and size of floats are determined based on the size of the trawl net, type of the net, depth of operation and target fish. HDPE floats are the most common floats in use. The number of floats usually varies from 5-17. A master float is attached at the centre of the head rope followed by smaller floats towards either sides. The diameter of the smaller floats ranges from 7.5-10 cm and for the master floats it ranges from 20 to 35 cm. In large mesh trawls, 3-5 large floats are used, in order to prevent the floats from entangling in meshes.

Sinkers

Iron and lead are the common materials used as sinkers. Lead pieces with cylindrical shape weighing 100-250 g each are used as sinkers. Iron chains (weight ranging from 35 to 70 kg) are also used in place of or in addition to lead sinkers.

Fish trawl
 Otter board : Rectangular flat wooden
 1000 x 700 mm; 60 kg each

Vessel L_{OA} : 10 - 16 m
 hp : 90 - 193
 Area : Kochi, Kerala

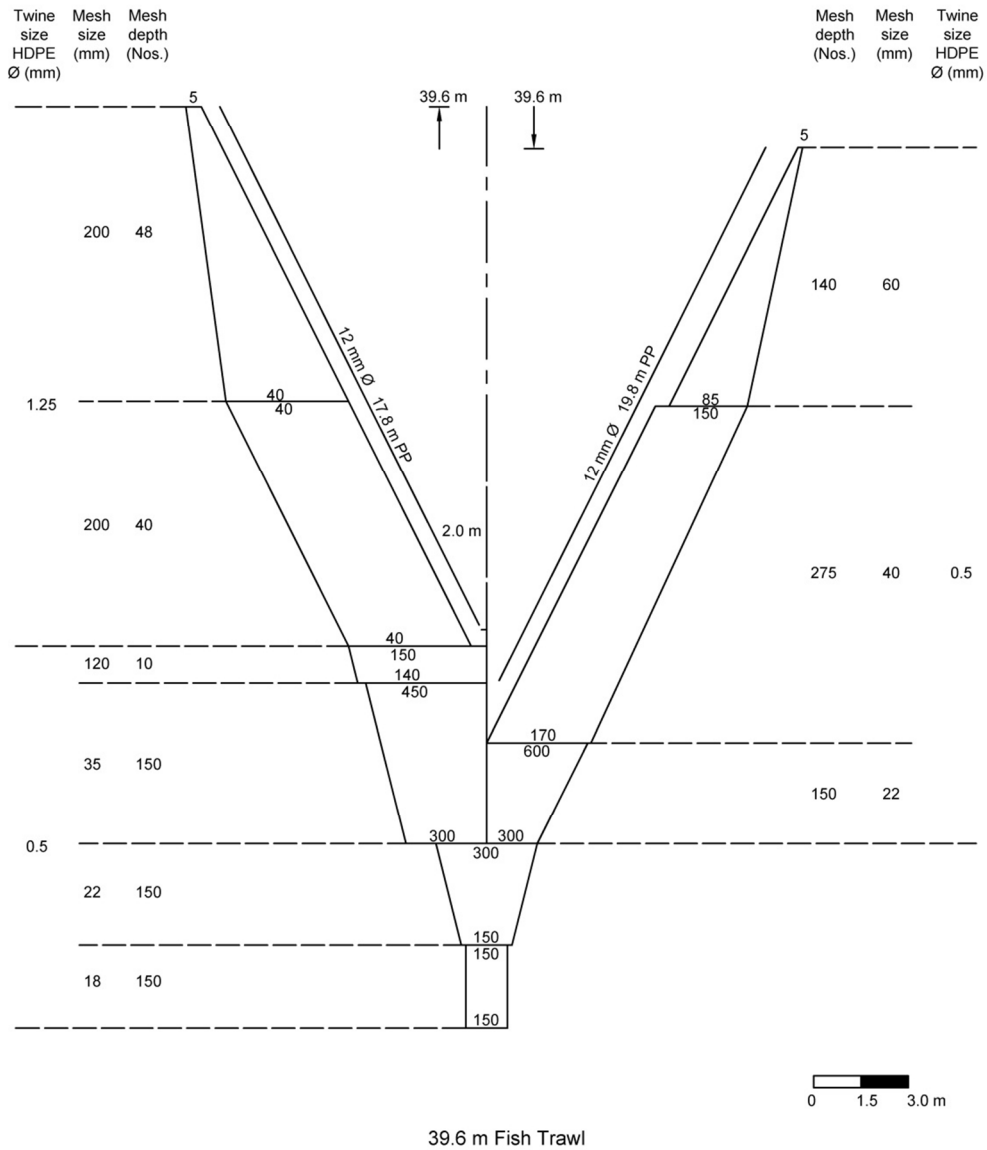
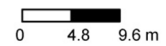
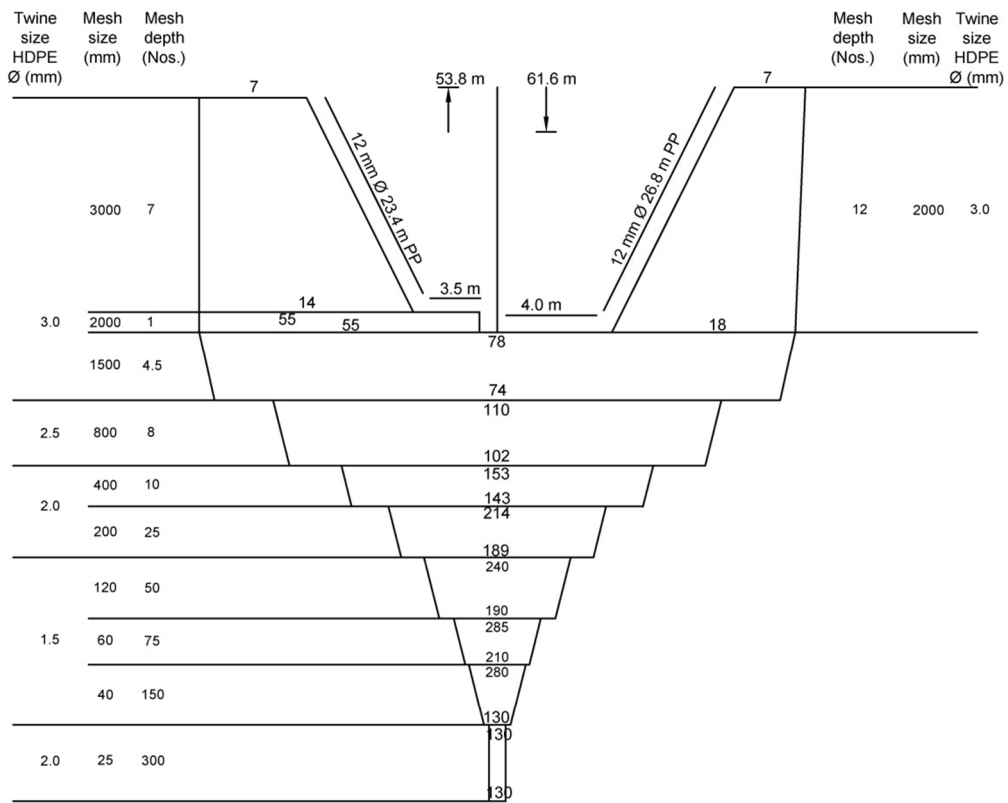

Fig. 5.6 Design of 39.6 m fish trawl

Fish trawl
 Otter board : 'V' form steel
 1380 x 800 mm; 100 kg each

Vessel L_{OA} : 17 - 23 m
 hp :190 - 380
 Area : Munambam, Kerala



53.8 m Fish Trawl

Fig. 5.7 Design of 53.8 m fish trawl

Fish trawl
 Otter board : 'V' form steel
 1500 x 890 mm; 110-120 kg each

Vessel L_{OA}: 15 - 19.5 m
 hp: 150 - 300
 Area: Kochi, Kerala

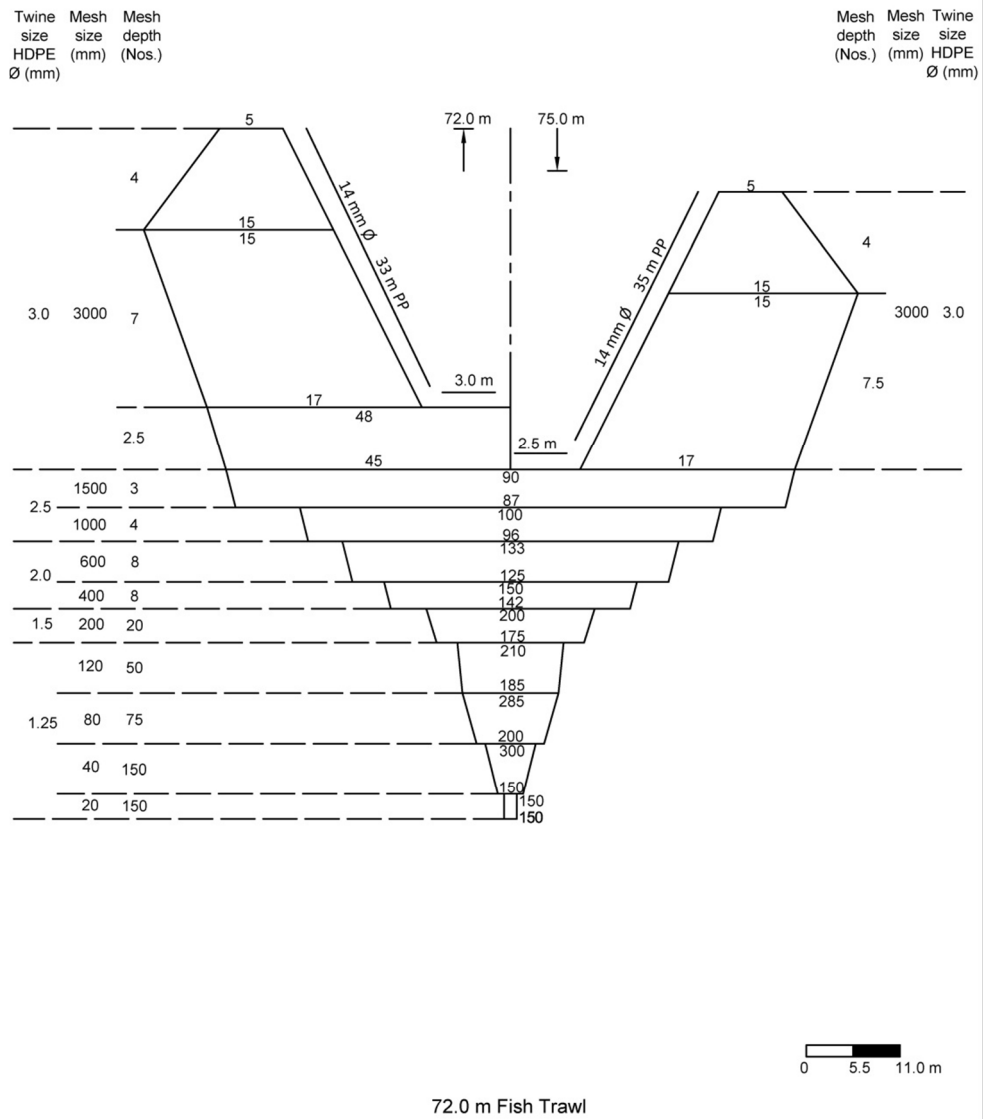
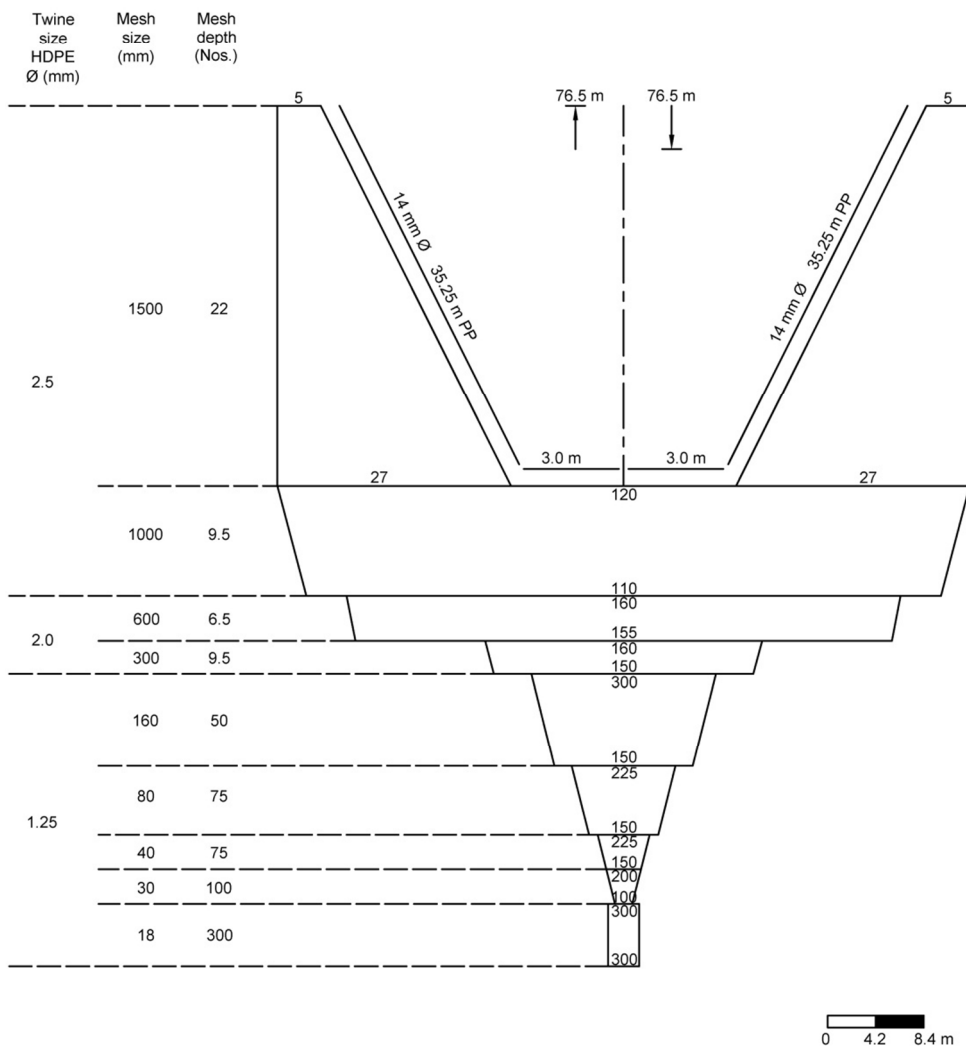

Fig. 5.8 Design of 72.0 m fish trawl

Fish trawl
 Otter board : 'V' form steel
 1000 x 700 mm; 80-110 kg each

Vessel L_{OA} : 15 - 20 m
 hp : 150 - 350
 Area: Kochi, Kasaragod, Kerala



76.5 m Fish Trawl

Fig. 5.9 Design of 76.5 m fish trawl

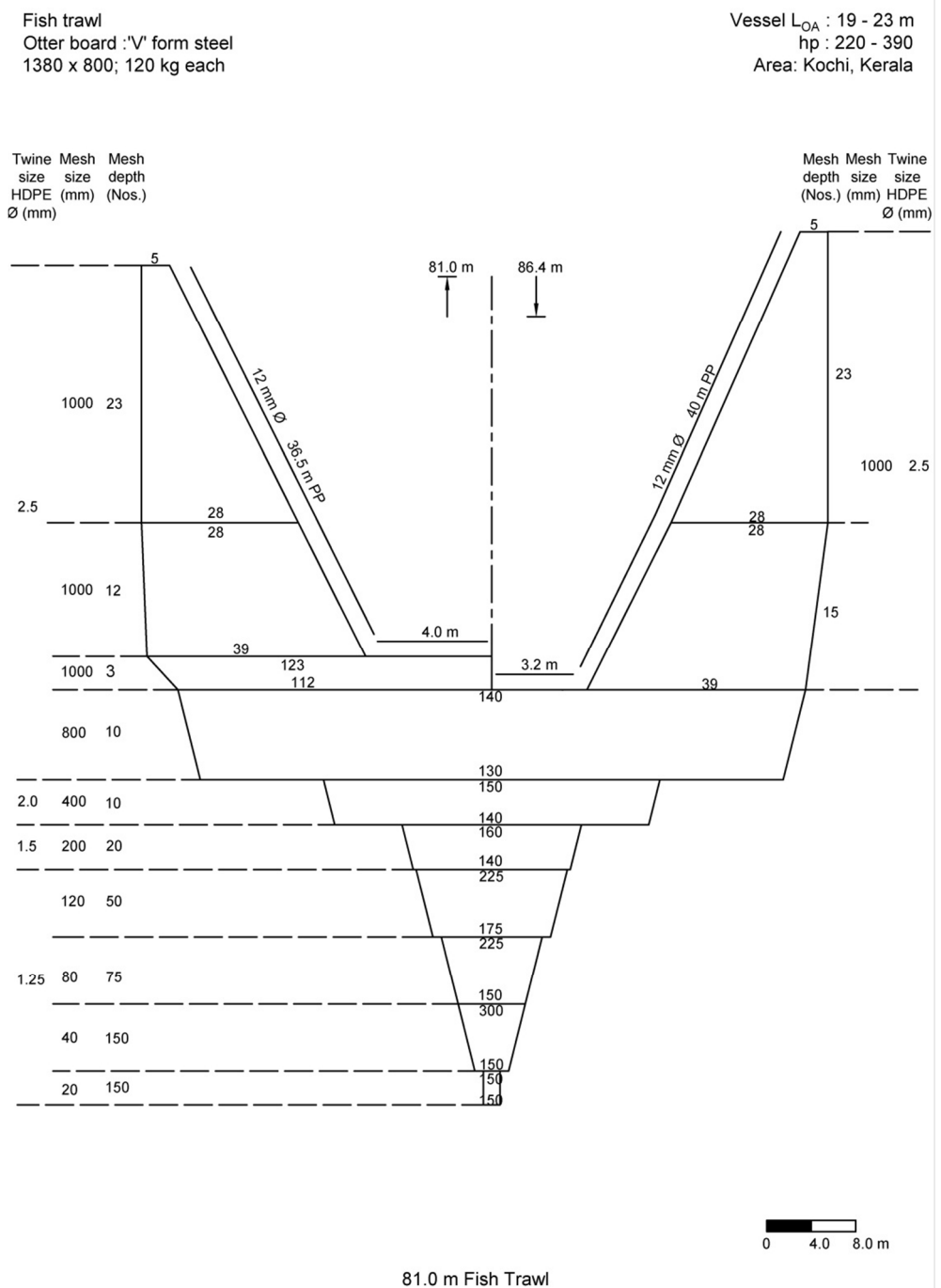

Fig. 5.10 Design of 81.0 m fish trawl

Fish trawl
 Otter board : 'V' form steel
 1380 x 800 mm; 120 kg each

Vessel L_{OA} : 21 - 28 m
 hp: 300 - 495
 Area: Munambam, Kerala

Twine size
 HDPE
 \varnothing (mm)

Mesh size (mm)

Mesh depth (Nos.)

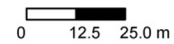
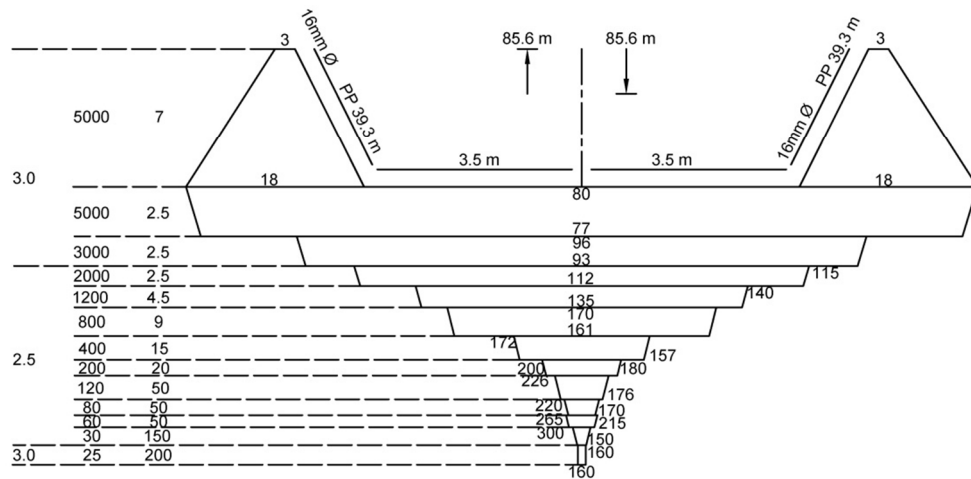

85.6 m Fish Trawl

Fig. 5.11 Design of 85.6 m fish trawl

Cephalopod (Octopus) trawl
 Otter board : 'V' form steel
 1380 x 800 mm; 80 kg each

Vessel L_{OA} : 14 - 19 m
 hp : 120 - 240
 Area : Munambam, Kerala

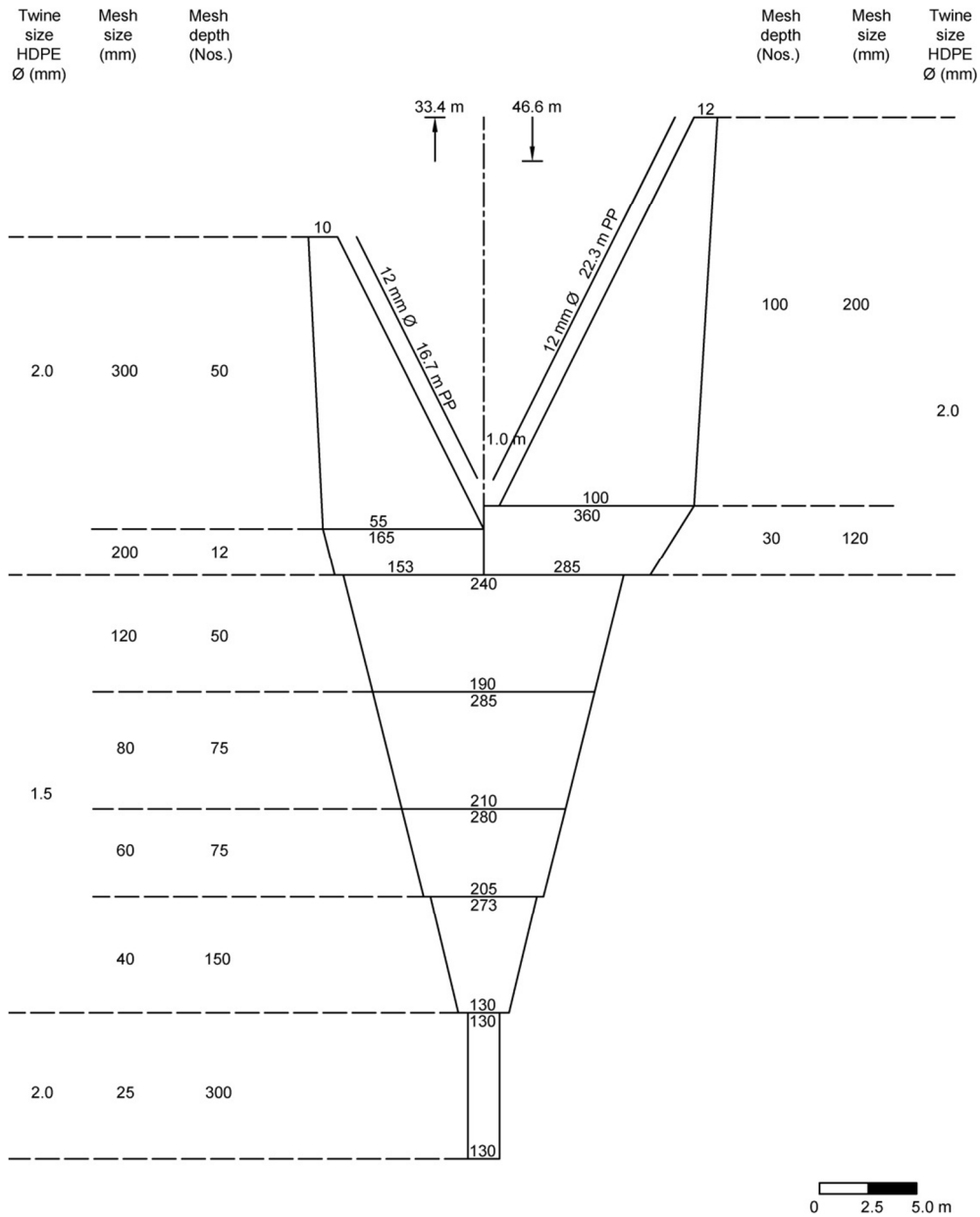

33.4 m Cephalopod Trawl

Fig. 5.12 Design of 33.4 m cephalopod trawl

Chapter 5 Life Cycle Assessment and Carbon Footprint of Trawl Gear Systems

Cephalopod (Cuttlefish) trawl
 Otter board : 'V' form steel
 1380 x 800 mm; 120 kg each

Vessel L_{OA} : 19- 28 m
 hp : 250 - 495
 Area : Munambam, Kerala

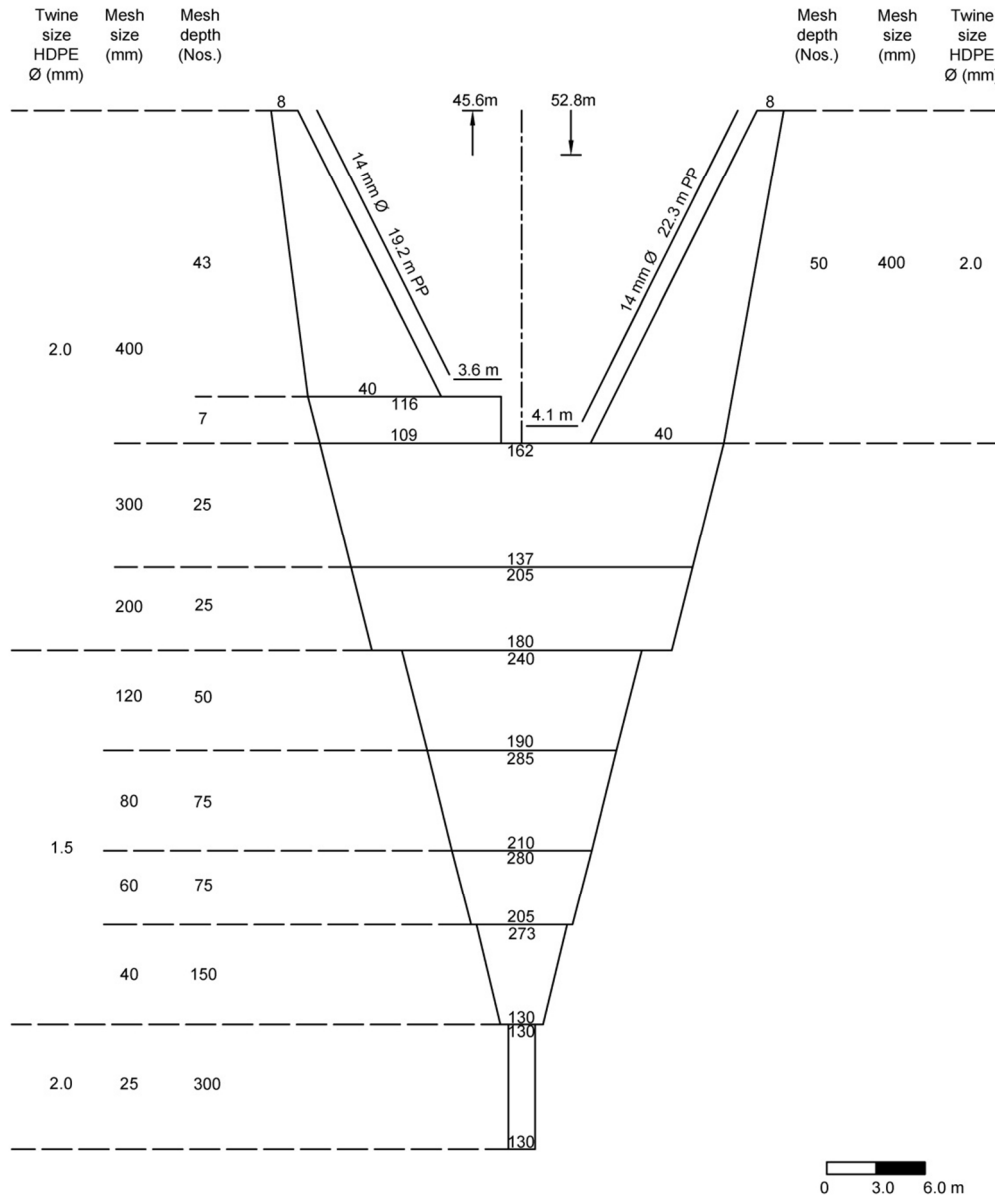

45.6 m Cephalopod Trawl

Fig. 5.13 Design of 45.6 m cephalopod trawl

Chapter 5 Life Cycle Assessment and Carbon Footprint of Trawl Gear Systems

Cephalopod (Cuttlefish) trawl
 Otter board : 'V' form steel
 1000 x 700 mm; 90-110 kg each

Vessel L_{OA} :14 - 20 m
 hp :120 - 300
 Area : Kochi, Kasaragod, Kerala

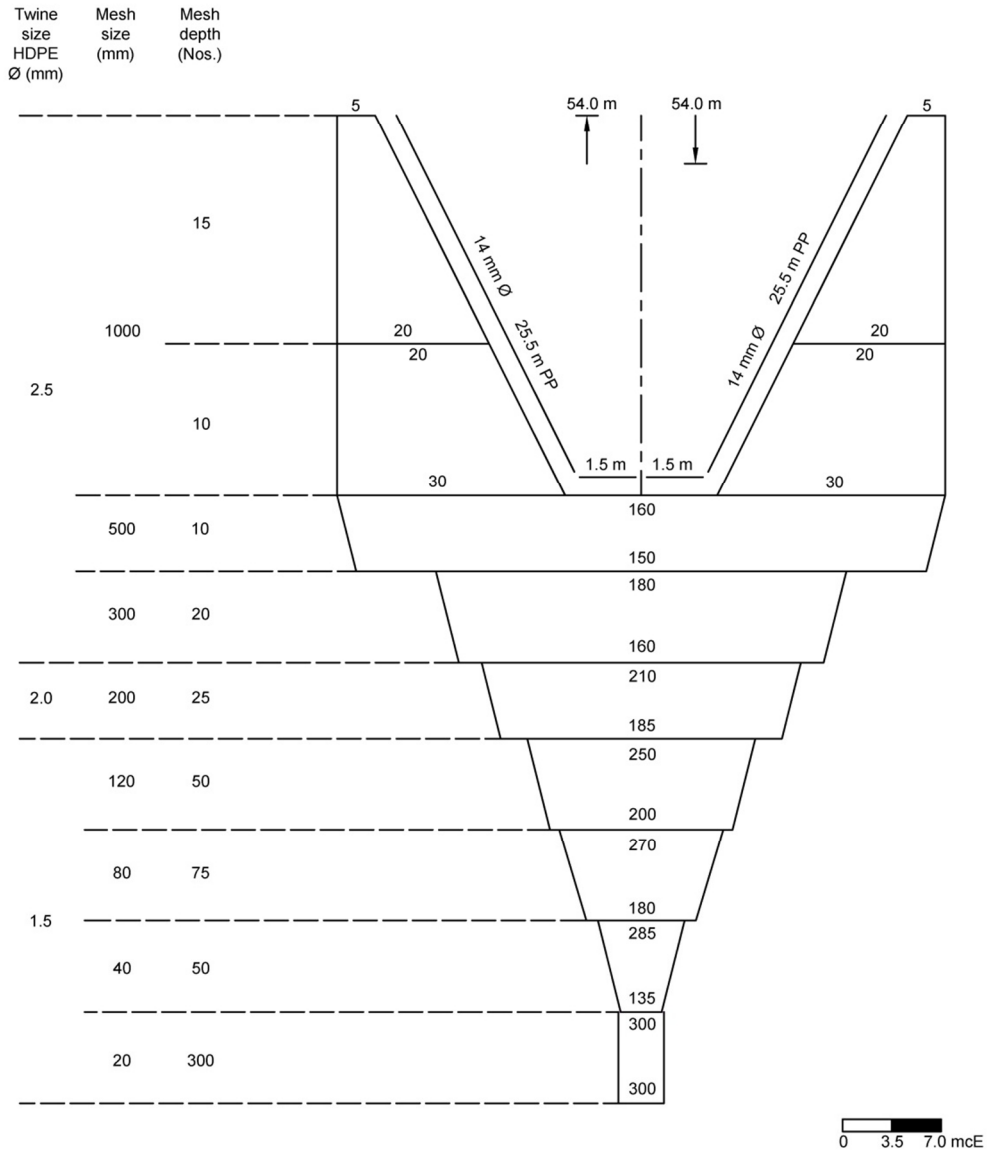

54.0 m Cephalopod Trawl

Fig. 5.14 Design of 54.0 m cephalopod trawl

Cephalopod (Squid) trawl
 Otter board : 'V' form steel
 1000 x 700 mm; 80 -120 kg each

Vessel L_{OA} : 16 - 21 m
 hp : 240 - 440
 Area : Kochi, Kasaragod, Kerala

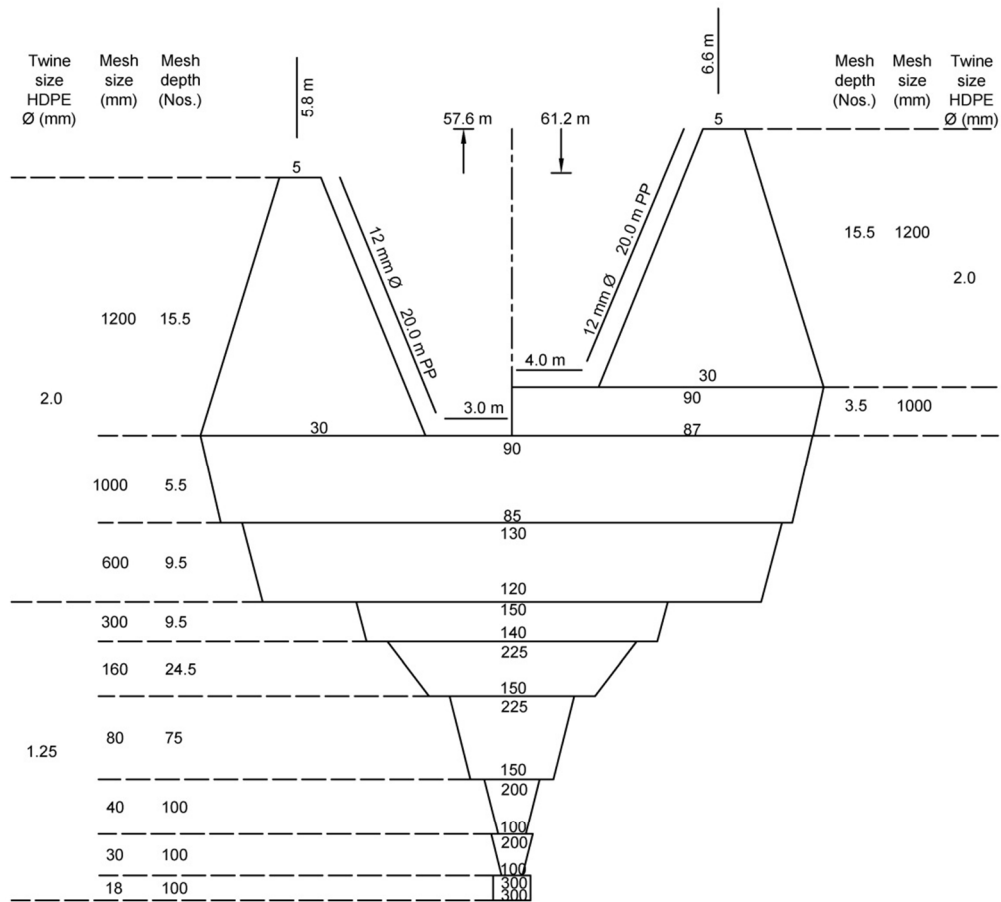

57.6 m Cephalopod Trawl

Fig. 5.15 Design of 57.6 m cephalopod trawl

Chapter 5 Life Cycle Assessment and Carbon Footprint of Trawl Gear Systems

Shrimp trawl
 Otter board :Rectangular flat wooden
 1000 x 700 mm; 60-80 kg each

Vessel L_{OA}: 9.5 - 14 m
 hp : 90 - 120
 Area : Kollam, Kerala

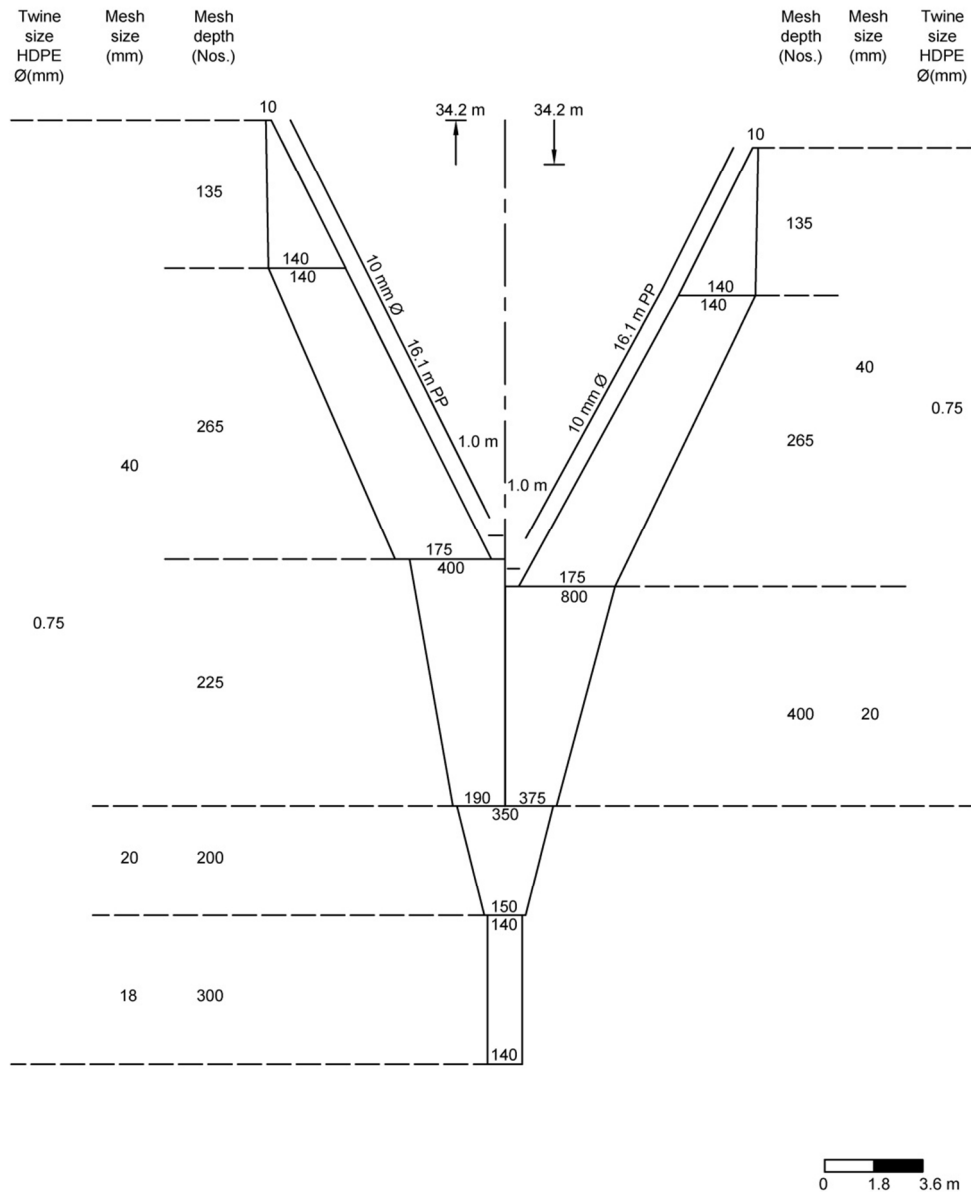
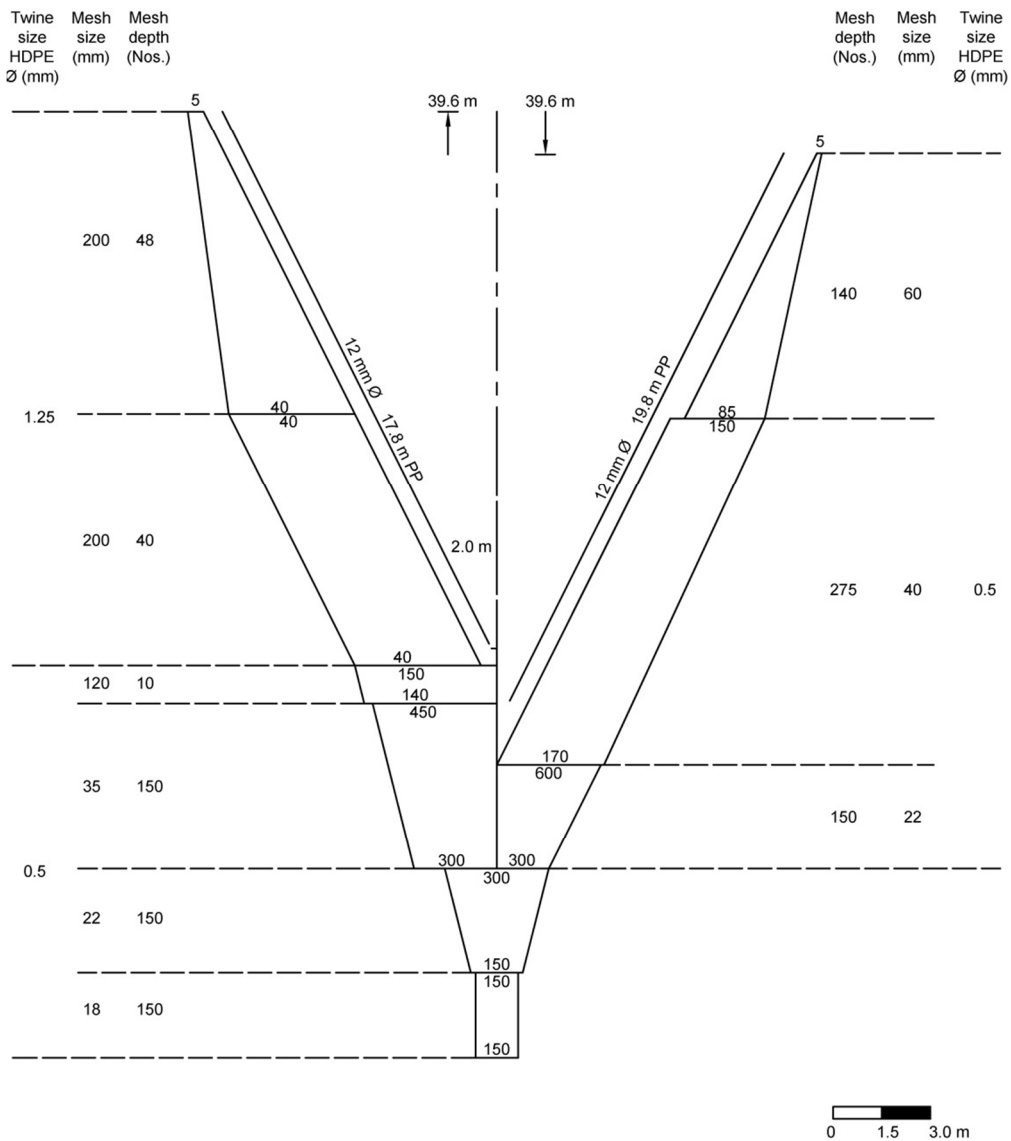

Fig. 5.16 Design of 34.2 m shrimp trawl

Shrimp trawl
 Otter board : Rectangular flat wooden
 1000 x 700 mm; 60 kg each

Vessel L_{OA} : 10 - 16 m
 hp : 90 - 193
 Area : Kochi, Kerala



39.6 m Shrimp Trawl
Fig. 5.17 Design of 39.6 m shrimp trawl

Shrimp trawl
 Otter board : 'V' form steel
 1000 x 700 mm; 80-110 kg each

Vessel L_{OA} : 15 - 19 m
 hp : 150 - 350
 Area : Kollam, Kerala

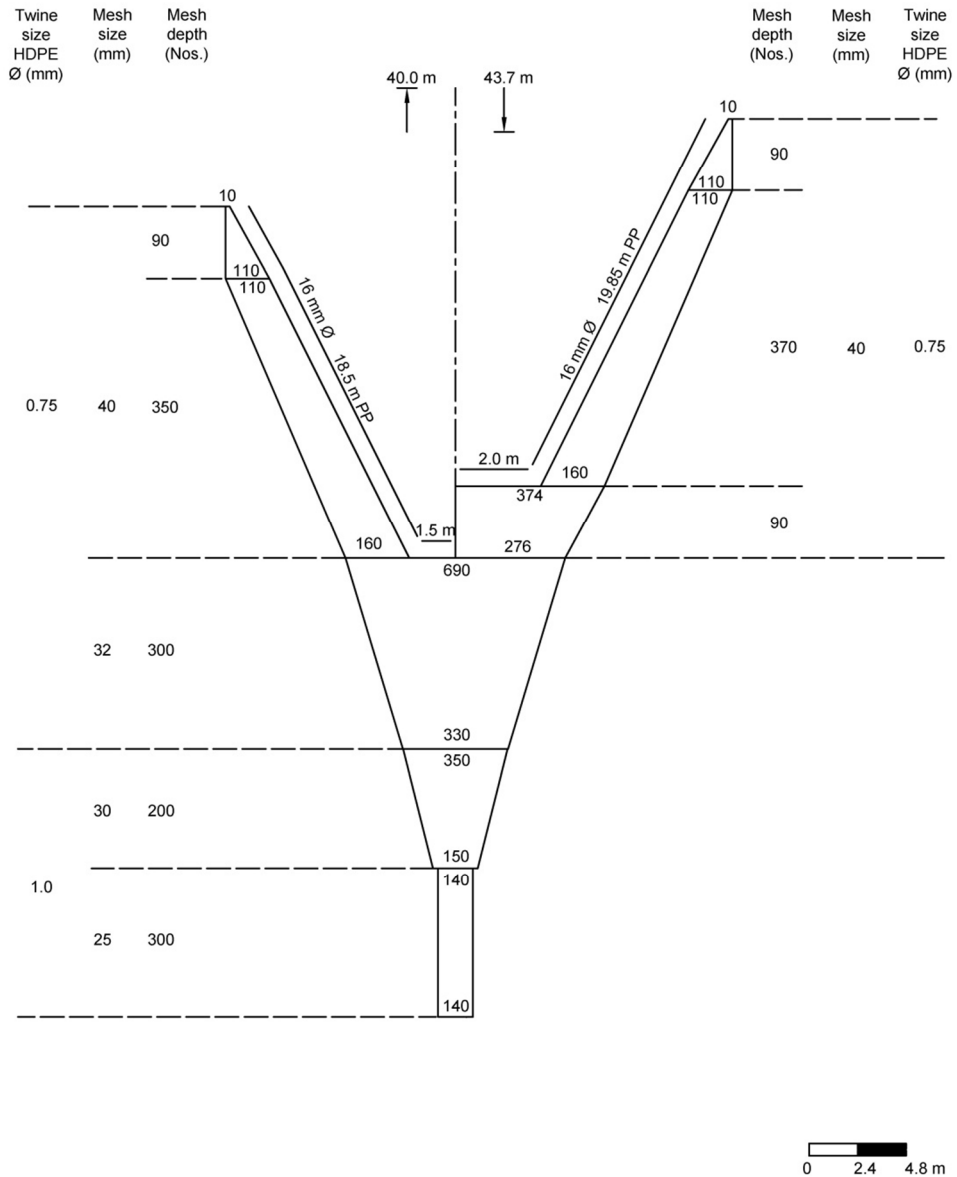

40.0 m Deep Sea Shrimp Trawl
Fig. 5.18 Design of 40.0 m shrimp trawl

Shrimp trawl
 Otter board : 'V' form steel
 1000 x 800 mm; 80 -110 kg each

Vessel L_{OA} : 13 - 16 m
 hp : 95 - 193
 Area : Kasaragod, Kerala

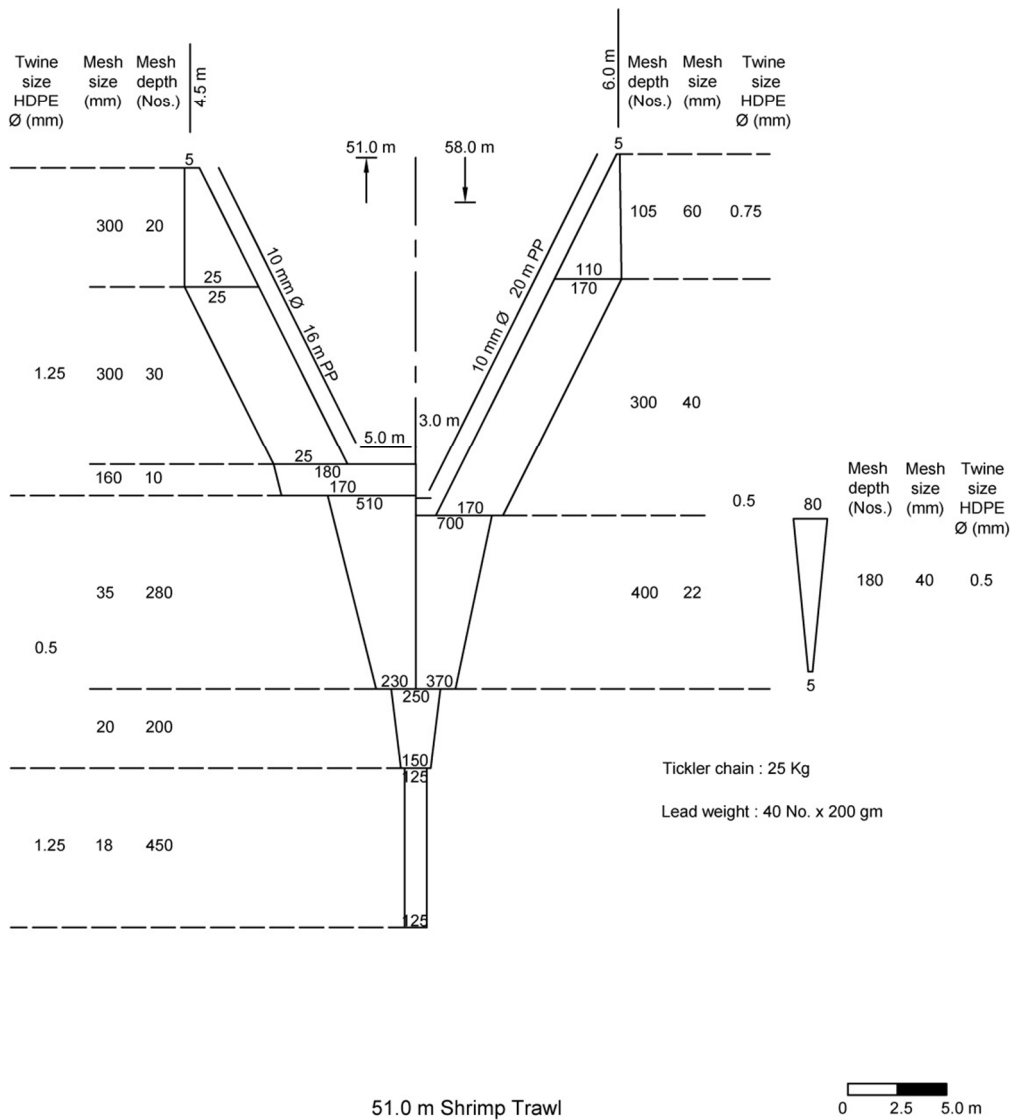

Fig. 5.19 Design of 51.0 m shrimp trawl

Shrimp trawl
 Otter board : 'V' form steel
 1380 x 800 mm; 120 kg each

Vessel L_{OA} : 15 - 28 m
 hp : 120 - 495
 Area : Kasaragod, Kochi, Kerala

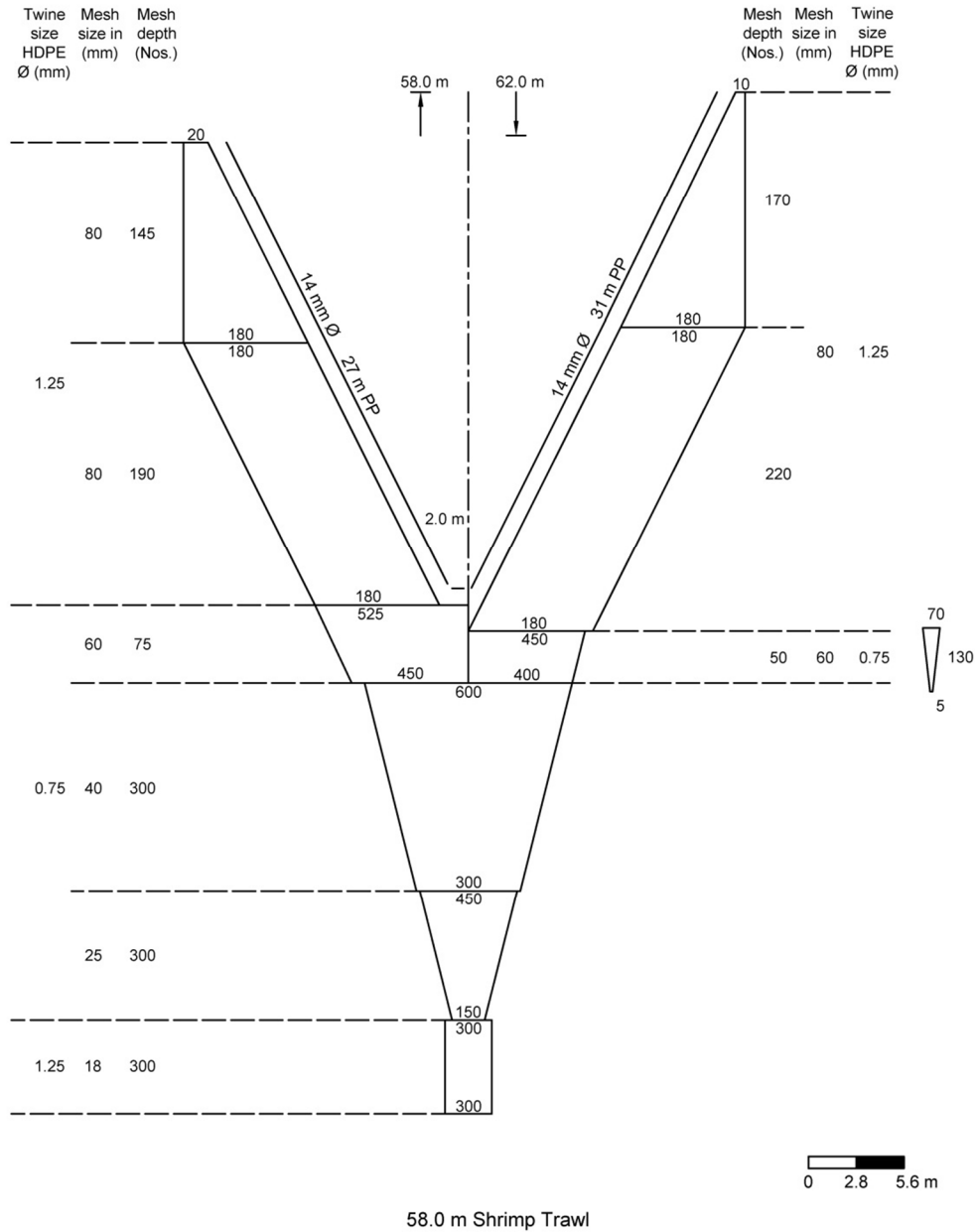

Fig. 5.20 Design of 58.0 m shrimp trawl

5.3.2 Life cycle inventory

The life cycle inventories of fish, cephalopod and shrimp trawls for their entire life cycles are shown in Table 5.2.

Table 5.2: Life cycle inventory of trawl nets (Fishing sub-system 2)

	HDPE webbing (kg)	PP rope (kg)	Iron sinkers (kg)	Lead sinkers (kg)	Floats (kg)
39.6 m fish trawl	10.61	5.21	20	10	3.48
53.8 m fish trawl	90.00	7.59	40	20	28.00
72.0 m fish trawl	68.49	13.36	50	-	19.72
76.5 m fish trawl	67.75	13.91	30	20	23.86
81.0 m fish trawl	69.71	11.01	40	20	27.14
85.6 m fish trawl	224.86	19.91	45	25	32.14
33.4 m cephalopod trawl	75.55	5.26	30	10	19.72
45.6 m cephalopod trawl	81.75	8.95	-	60	28.00
54.0 m cephalopod trawl	83.60	9.82	30	20	19.43
57.6 m cephalopod trawl	36.68	7.84	-	45	16.95
34.2 m shrimp trawl	18.51	3.11	20	20	4.19
39.6 m shrimp trawl	10.61	5.21	20	10	3.48
40.0 m shrimp trawl	27.87	9.73	30	10	7.74
51.0 m shrimp trawl	21.00	12.67	25	8	13.27
58.0 m shrimp trawl	63.87	10.91	30	20	11.87

In the case of fish trawls, HDPE webbing used for construction ranged from 10.61 to 224.86 kg, PP rope 5.21 - 19.91 kg, iron sinker 20 - 50 kg, lead sinker 10 - 25 kg and floats 3.48 - 32.14 kg. In the case of cephalopod trawls, HDPE webbing used for construction ranged from 36.68 to 83.60 kg, PP rope 5.26 - 9.82 kg, iron sinker 30 kg, lead sinker 10 - 60 kg and floats 16.95 - 28 kg. In the case of shrimp trawls, HDPE webbing used for construction ranged from 10.61 to 63.87 kg, PP rope 3.11 - 12.67 kg, iron sinker 20 - 30 kg, lead sinker 8 - 20 kg and floats 3.48 - 13.27 kg.

5.3.3 Life cycle impact assessment

Under Life Cycle Assessment of trawl nets, seven impact categories *viz.* Global warming potential (GWP), Abiotic depletion potential-fossil (ADP-fossil), Acidification potential (AP), Eutrophication potential (EP), Marine aquatic ecotoxicity potential (MAETP), Ozone depletion potential (ODP) and Photochemical ozone creation potential (POCP) were considered.

5.3.3.1 Global warming potential

Global warming potential (GWP) from different trawl nets *viz.*, fish trawls, cephalopod trawls and shrimp trawls are given in Fig. 5.21. Among the materials used for construction of 39.6 m fish trawl, GWP was maximum for iron sinker (64.6%) followed by HDPE webbing (17.0%), PP rope (10.3%), HDPE float (5.0%) and lead sinker (3.1%). In the case of 53.8 m fish trawl, GWP was maximum for HDPE webbing (39.4%) followed by iron sinker (35.3%), HDPE float (19.6%), PP rope (4.1%) and lead sinker (1.7%). In the case of 72 m fish trawl, GWP was maximum for iron sinker (48.1%) followed by HDPE webbing (32.7%), HDPE float (11.3%) and PP rope (7.9%). In the case of 76.5 m fish trawl, GWP was maximum for HDPE webbing (36.1%) followed by iron sinker (32.3%), HDPE float (20.3%), PP rope (9.2%) and lead sinker (2.1%). In the case of 81.0 m fish trawl, GWP was maximum for iron sinker (41.9%) followed by HDPE webbing (36.3%), HDPE float (12.7%), PP rope (7.1%) and lead sinker (2.0%). In the case of 85.6 m fish trawl, GWP was maximum for HDPE webbing (56.7%) followed by iron sinker (22.9%), HDPE float (12.9%), PP rope (6.2%) and lead sinker (1.2%).

Among the materials used for construction of 33.4 m cephalopod trawl, GWP was maximum for HDPE webbing (42.9%) followed by iron sinker (34.4%), HDPE float (17.9%), PP rope (3.7%) and lead sinker (1.1%). In the case of 45.6 m cephalopod trawl, GWP was maximum for HDPE webbing (54.8%) followed by HDPE float (29.9%), lead sinker (7.9%) and PP rope (7.4%). In the case of 54.0 m cephalopod trawl, GWP was maximum for HDPE webbing (47.1%) followed by iron sinker (34.1%), HDPE float (9.8%), PP rope (6.8%) and lead sinker (2.2%). In the case of 57.6 m cephalopod trawl, GWP was maximum for HDPE webbing (44.6%) followed by HDPE float (32.9%), PP rope (11.8%) and lead sinker (10.7%).

Among the materials used for construction of 34.2 m shrimp trawl, GWP was maximum for iron sinker (55.0%) followed by HDPE webbing (25.3%), HDPE float (9.1%), lead sinker (5.4%) and PP rope (5.2%). In the case of 39.6 m shrimp trawl, GWP was maximum for iron sinker (64.6%) followed by HDPE webbing (17.0%), PP rope (10.3%), HDPE float (5.0%) and lead sinker (3.1%). In the case of 40.0 m shrimp trawl, GWP was maximum for iron sinker (52.7%) followed by HDPE webbing (24.3%), HDPE float (10.8%), PP rope (10.5%) and lead sinker (1.7%). In the case of 51.0 m shrimp trawl, GWP was maximum for iron sinker (45.9%) followed by HDPE float (19.3%), HDPE webbing (19.1%), PP rope (14.3%) and lead sinker (1.4%). In the case of 58.0 m shrimp trawl, GWP was maximum for HDPE webbing (41.9%) followed by iron sinker (39.7%), PP rope (8.8%), HDPE float (7.0%) and lead sinker (2.6%).

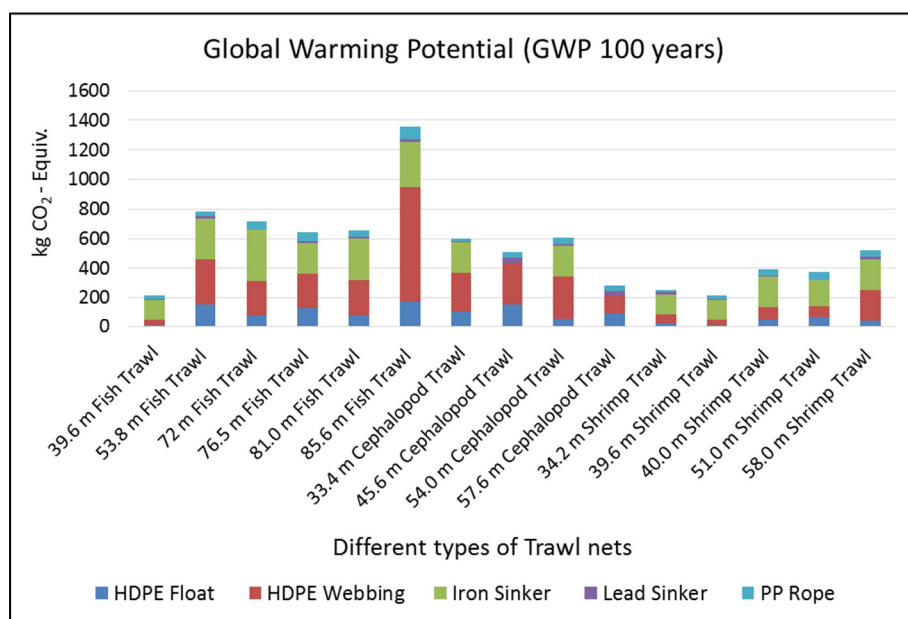

Fig. 5.21. Global warming potential from different trawl nets

5.3.3.2 Abiotic depletion potential (fossil)

Abiotic depletion potential (fossil) (ADP - fossil) from different trawl nets viz., fish trawls, cephalopod trawls and shrimp trawls are shown in Fig. 5.22. In the case of 39.6 m fish trawl, ADP - fossil was maximum for iron sinker (44.5%) followed by HDPE webbing (29.6%), PP rope (15.6%), HDPE float (7.8%) and lead sinker (2.6%). In the case of 53.8 m fish trawl, ADP - fossil was maximum for HDPE webbing (52.3%) followed by HDPE float (23.3%), iron sinker (18.6%), PP rope (4.7%) and lead sinker (1.1%). In the case of 72 m fish trawl, ADP - fossil was maximum for HDPE webbing (47.6%) followed by iron sinker (27.7%), HDPE float (14.7%) and PP rope (10.0%). In the case of 76.5 m fish trawl, ADP - fossil was maximum for HDPE webbing (47.5%) followed by HDPE float (24.0%), iron sinker (16.8%), PP rope (10.4%) and lead sinker (1.3%). In the case of 81.0 m fish trawl, ADP - fossil was maximum for HDPE webbing (50.8%) followed by

iron sinker (23.3%), HDPE float (15.9%), PP rope (8.6%) and lead sinker (1.4%). In the case of 85.6 m fish trawl, ADP - fossil was maximum for HDPE webbing (68.0%) followed by HDPE float (13.9%), iron sinker (10.9%), PP rope (6.5%) and lead sinker (0.7%).

Among the materials used for construction of 33.4 m cephalopod trawl, ADP - fossil was maximum for HDPE webbing (56.3%) followed by HDPE float (21.0%), iron sinker (17.8%), PP rope (4.2%) and lead sinker (0.7%). In the case of 45.6 m cephalopod trawl, ADP - fossil was maximum for HDPE webbing (59.7%) followed by HDPE float (29.3%), PP rope (7.0%) and lead sinker (4.1%). In the case of 54.0 m cephalopod trawl, ADP - fossil was maximum for HDPE webbing (61.7%), iron sinker (17.7%), HDPE float (11.5%), PP rope (7.8%) and lead sinker (1.4%). In the case of 57.6 m cephalopod trawl, ADP - fossil was maximum for HDPE webbing (49.9%) followed by HDPE float (33.0%), PP rope (11.4%) and lead sinker (5.7%).

Among the materials used for construction of 34.2 m shrimp trawl, ADP - fossil was maximum for HDPE webbing (40.5%) followed by iron sinker (35.0%), HDPE float (13.1%), PP rope (7.3%) and lead sinker (4.1%). In the case of 39.6 m shrimp trawl, ADP - fossil was maximum for iron sinker (44.5%) followed by HDPE webbing (29.6%), PP rope (15.6%), HDPE float (7.8%) and lead sinker (2.6%). In the case of 40.0 m shrimp trawl, ADP - fossil was maximum for HDPE webbing (37.5%) followed by iron sinker (32.2%), HDPE float (14.9%), PP rope (14.0%) and lead sinker (1.2%). In the case of 51.0 m shrimp trawl, ADP - fossil was maximum for HDPE webbing (28.3%) followed by iron sinker (26.9%), HDPE float (25.6%), PP rope (18.3%) and lead sinker (1.0%). In the case of 58.0 m shrimp trawl, ADP - fossil was maximum for HDPE webbing (57.6%) followed by iron sinker (21.6%), PP rope (10.5%), HDPE float (8.6%) and lead sinker (1.7%).

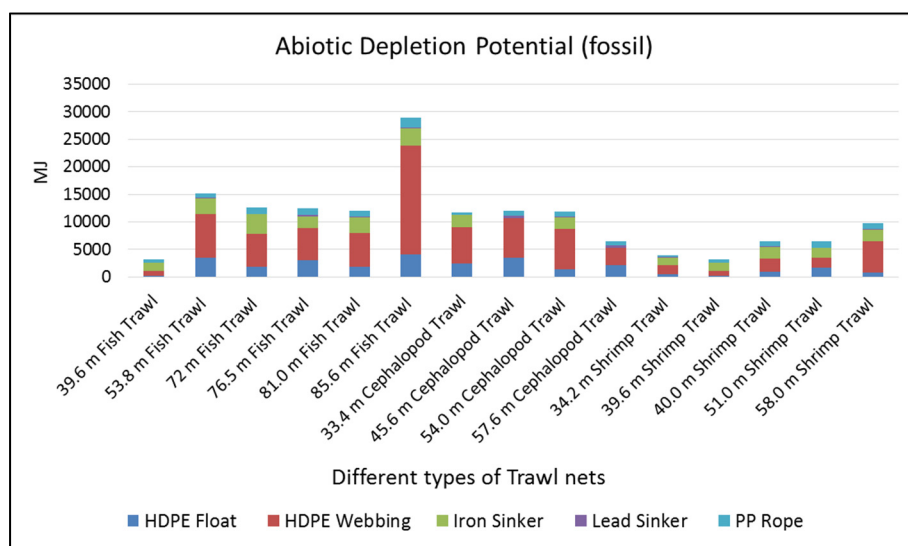

Fig. 5.22 Abiotic depletion potential (fossil) from different trawl nets

5.3.3.3 Acidification potential

Acidification potential (AP) from different trawl nets *viz.*, fish trawls, cephalopod trawls and shrimp trawls are shown in Fig. 5.23. Among the materials used for construction of 39.6 m fish trawl, AP was maximum for iron sinker (62.1%) followed by HDPE webbing (14.3%), lead sinker (9.8%), PP rope (9.2%) and HDPE float (4.6%). In the case of 53.8 m fish trawl, AP was maximum for iron sinker (36.1%) followed by HDPE webbing (35.1%), HDPE float (19.2%), lead sinker (5.7%) and PP rope (3.9%). In the case of 72 m fish trawl, AP was maximum for iron sinker (50.8%) followed by HDPE webbing (30.1%), HDPE float (11.4%) and PP rope (7.7%). In the case of 76.5 m fish trawl, AP was maximum for iron sinker (32.7%) followed by HDPE webbing (32.0%), HDPE float (19.8%), PP rope (8.6%) and lead sinker (6.9%). In the case of 81.0 m fish trawl, AP was maximum for iron sinker (42.4%) followed by HDPE webbing (32.0%), HDPE float (12.3%), lead

sinker (6.7%) and PP rope (6.6%). In the case of 85.6 m fish trawl, AP was maximum for HDPE webbing (52.3%) followed by iron sinker (24.2%), HDPE float (13.2%), PP rope (6.1%) and lead sinker (4.2%).

Among the materials used for construction of 33.4 m cephalopod trawl, AP was maximum for HDPE webbing (39.0%) followed by iron sinker (35.8%), HDPE float (17.9%), lead sinker (3.8%) and PP rope (3.6%). In the case of 45.6 m cephalopod trawl, AP was maximum for HDPE webbing (43.8%) followed by HDPE float (26.4%), lead sinker (23.5%) and PP rope (6.3%). In the case of 54.0 m cephalopod trawl, AP was maximum for HDPE webbing (41.9%) followed by iron sinker (34.7%), HDPE float (9.6%), lead sinker (7.3%) and PP rope (6.4%). In the case of 57.6 m cephalopod trawl, AP was maximum for HDPE webbing (33.5%) followed by lead sinker (30.0%), HDPE float (27.2%) and PP rope (9.4%).

Among the materials used for construction of 34.2 m shrimp trawl, AP was maximum for iron sinker (50.9%) followed by HDPE webbing (20.4%), lead sinker (16.1%), HDPE float (8.1%) and PP rope (4.5%). In the case of 39.6 m shrimp trawl, AP was maximum for iron sinker (62.1%) followed by HDPE webbing (14.3%), lead sinker (9.8%), PP rope (9.2%) and HDPE float (4.6%). In the case of 40.0 m shrimp trawl, AP was maximum for iron sinker (53.0%) followed by HDPE webbing (21.3%), HDPE float (10.4%), PP rope (9.7%) and lead sinker (5.6%). In the case of 51.0 m shrimp trawl, AP was maximum for iron sinker (46.4%) followed by HDPE float (18.7%), HDPE webbing (16.9%), PP rope (13.3%) and lead sinker (4.7%). In the case of 58.0 m shrimp trawl, AP was maximum for iron sinker (39.9%) followed by HDPE webbing (36.7%), lead sinker (8.4%), PP rope (8.2%) and HDPE float (6.8%).

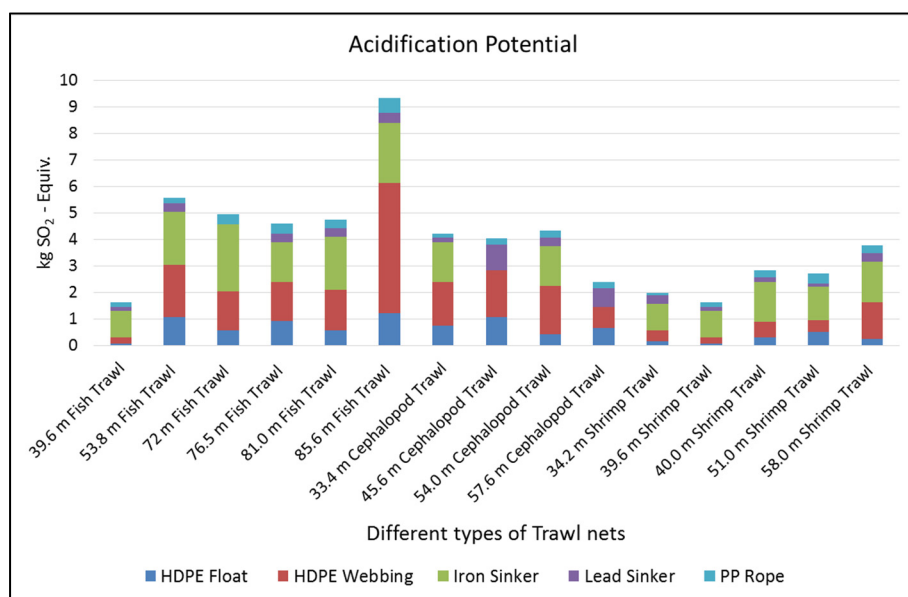

Fig. 5.23 Acidification potential from different trawl nets

5.3.3.4 Eutrophication potential

Eutrophication potential (EP) from different trawl nets *viz.*, fish trawls, cephalopod trawls and shrimp trawls are shown in Fig. 5.24. Among the materials used for construction of 39.6 m fish trawl, EP was maximum for iron sinker (65.6%) followed by HDPE webbing (16.6%), PP rope (10.4%), HDPE float (5.2%) and lead sinker (2.2%). In the case of 53.8 m fish trawl, EP was maximum for HDPE webbing (38.4%) followed by iron sinker (35.8%), HDPE float (20.5%), PP rope (4.1%) and lead sinker (1.2%). In the case of 72 m fish trawl, EP was maximum for iron sinker (48.6%) followed by HDPE webbing (31.7%), HDPE float (11.7%) and PP rope (7.9%). In the case of 76.5 m fish trawl, EP was maximum for HDPE webbing (35.3%) followed by iron sinker (32.8%), HDPE float (21.3%), PP rope (9.2%) and lead sinker (1.5%). In the case of 81.0 m fish trawl, EP was maximum for iron sinker (42.7%) followed by HDPE webbing (35.4%), HDPE float (13.3%), PP rope (7.1%)

and lead sinker (1.4%). In the case of 85.6 m fish trawl, EP was maximum for HDPE webbing (55.8%) followed by iron sinker (23.4%), HDPE float (13.6%), PP rope (6.3%) and lead sinker (0.9%).

Among the materials used for construction of 33.4 m cephalopod trawl, EP was maximum for HDPE webbing (41.9%) followed by iron sinker (34.9%), HDPE float (18.7%), PP rope (3.7%) and lead sinker (0.8%). In the case of 45.6 m cephalopod trawl, EP was maximum for HDPE webbing (54.7%) followed by HDPE float (32.1%), PP rope (7.6%) and lead sinker (5.7%). In the case of 54.0 m cephalopod trawl, EP was maximum for HDPE webbing (46.3%) followed by iron sinker (34.9%), HDPE float (10.4%), PP rope (6.9%) and lead sinker (1.6%). In the case of 57.6 m cephalopod trawl, EP was maximum for HDPE webbing (44.7%) followed by HDPE float (35.4%), PP rope (12.2%) and lead sinker (7.7%).

Among the materials used for construction of 34.2 m shrimp trawl, EP was maximum for iron sinker (56.4%) followed by HDPE webbing (24.9%), HDPE float (9.6%), PP rope (5.3%) and lead sinker (3.8%). In the case of 39.6 m shrimp trawl, EP was maximum for iron sinker (65.6%) followed by HDPE webbing (16.6%), PP rope (10.4%), HDPE float (5.2%) and lead sinker (2.2%). In the case of 40.0 m shrimp trawl, EP was maximum for iron sinker (53.4%) followed by HDPE webbing (23.6%), HDPE float (11.2%), PP rope (10.5%) and lead sinker (1.2%). In the case of 51.0 m shrimp trawl, EP was maximum for iron sinker (46.2%) followed by HDPE float (20.0%), HDPE webbing (18.5%), PP rope (14.2%) and lead sinker (1.0%). In the case of 58.0 m shrimp trawl, EP was maximum for HDPE webbing (41.2%) followed by iron sinker (40.6%), PP rope (9.0%), HDPE float (7.4%) and lead sinker (1.8%).

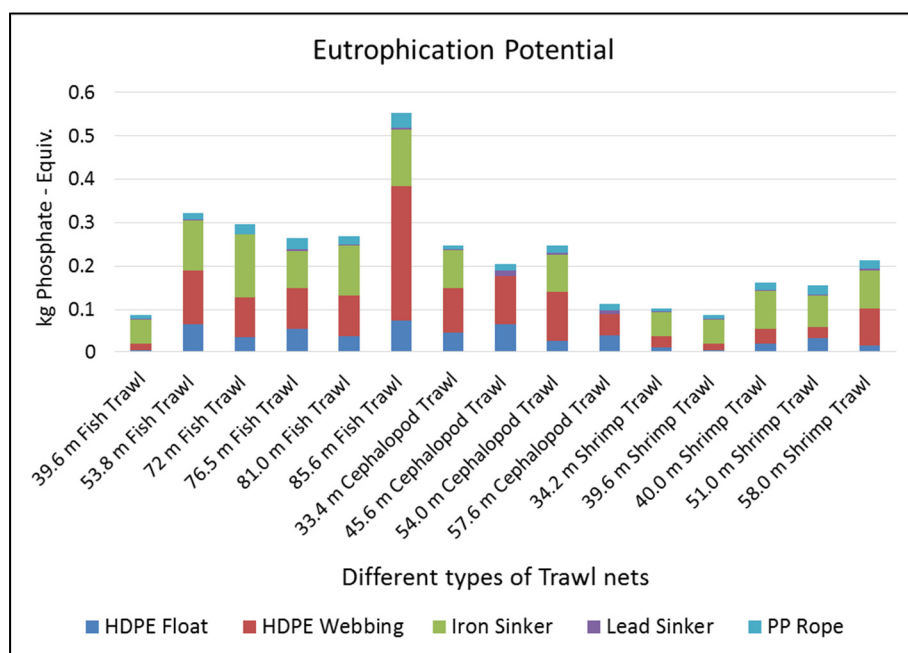

Fig. 5.24 Eutrophication potential from different trawl nets

5.3.3.5 Marine aquatic ecotoxicity potential

Marine aquatic ecotoxicity potential (MAETP) from different trawl nets *viz.*, fish trawls, cephalopod trawls and shrimp trawls are shown in Fig. 5.25. Among the materials used for construction of 39.6 m fish trawl, MAETP was maximum for iron sinker (68.9%) followed by HDPE webbing (15.3%), PP rope (10.4%), HDPE float (5.2%) and lead sinker (0.2%). In the case of 53.8 m fish trawl, MAETP was maximum for iron sinker (38.6%) followed by HDPE webbing (36.3%), HDPE float (20.8%), PP rope (4.2%) and lead sinker (0.1%). In the case of 72 m fish trawl, MAETP was maximum for iron sinker (51.1%), followed by HDPE webbing (29.3%), HDPE float (11.6%) and PP rope (7.9%). In the case of 76.5 m fish trawl, MAETP was maximum for iron sinker (35.3%) followed by HDPE webbing (33.4%), HDPE float (21.6%), PP rope (9.5%) and lead sinker (0.1%). In the case of 81.0 m fish trawl, MAETP was maximum for iron sinker (45.8%) followed by HDPE webbing (33.4%),

HDPE float (13.5%), PP rope (7.3%) and lead sinker (0.1%). In the case of 85.6 m fish trawl, MAETP was maximum for HDPE webbing (53.6%) followed by iron sinker (25.6%), HDPE float (14.1%), PP rope (6.6%) and lead sinker (0.1%).

Among the materials used for construction of 33.4 m cephalopod trawl, MAETP was maximum for HDPE webbing (39.6%) followed by iron sinker (37.5%), HDPE float (19.0%), PP rope (3.8%) and lead sinker (0.1%). In the case of 45.6 m cephalopod trawl, MAETP was maximum for HDPE webbing (55.9%) followed by HDPE float (35.2%), PP rope (8.5%) and lead sinker (0.4%). In the case of 54.0 m cephalopod trawl, MAETP was maximum for HDPE webbing (44.2%) followed by iron sinker (37.9%), HDPE float (10.6%), PP rope (7.2%) and lead sinker (0.1%). In the case of 57.6 m cephalopod trawl, MAETP was maximum for HDPE webbing (46.3%) followed by HDPE float (39.4%), PP rope (13.7%) and lead sinker (0.6%).

Among the materials used for construction of 34.2 m shrimp trawl, MAETP was maximum for iron sinker (60.8%) followed by HDPE webbing (23.6%), HDPE float (9.8%), PP rope (5.5%) and lead sinker (0.3%). In the case of 39.6 m shrimp trawl, MAETP was maximum for iron sinker (68.9%) followed by HDPE webbing (15.3%), PP rope (10.4%), HDPE float (5.2%) and lead sinker (0.2%). In the case of 40.0 m shrimp trawl, MAETP was maximum for iron sinker (56.3%) followed by HDPE webbing (21.9%), HDPE float (11.2%), PP rope (10.6%) and lead sinker (0.1%). In the case of 51.0 m shrimp trawl, MAETP was maximum for iron sinker (48.6%) followed by HDPE float (19.9%), HDPE webbing (17.1%), PP rope (14.3%) and lead sinker (0.1%). In the case of 58.0 m shrimp trawl, MAETP was maximum for iron sinker (43.9%) followed by HDPE webbing (39.2%), PP rope (9.2%), HDPE float (7.5%) and lead sinker (0.1%).

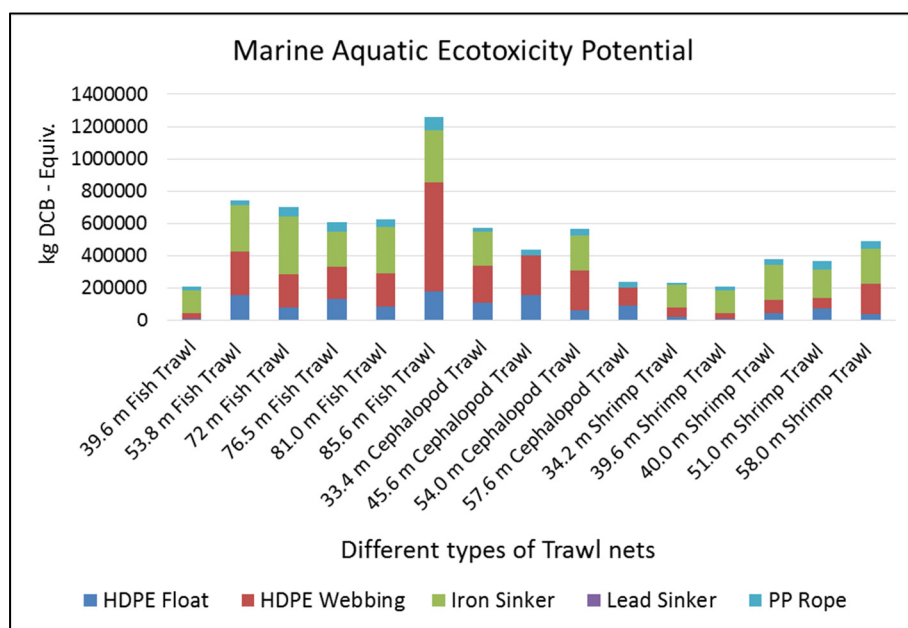

Fig. 5.25 Marine aquatic ecotoxicity potential from different trawl nets

5.3.3.6 Ozone depletion potential

Ozone layer depletion potential (ODP) from different trawl nets *viz.*, fish trawls, cephalopod trawls and shrimp trawls are shown in Fig. 5.26. Among the materials used for construction of 39.6 m fish trawl, ODP was maximum for HDPE webbing (34.9%) followed by iron sinker (31.8%), PP rope (19.1%), HDPE float (9.2%) and lead sinker (4.9%). In the case of 53.8 m fish trawl, ODP was maximum for HDPE webbing (56.0%) followed by HDPE float (24.9%), iron sinker (12.0%), PP rope (5.2%) and lead sinker (1.9%). In the case of 72 m fish trawl, ODP was maximum for HDPE webbing (53.2%) followed by iron sinker (18.8%), HDPE float (16.4%) and PP rope (11.5%). In the case of 76.5 m fish trawl, ODP was maximum for HDPE webbing (50.3%) followed by HDPE float (25.3%), PP rope (11.5%), iron sinker (10.8%) and lead sinker (2.2%). In the case of 81.0 m fish trawl, ODP was maximum for HDPE webbing (55.3%) followed by HDPE float (17.3%), iron sinker (15.3%), PP

rope (9.7%) and lead sinker (2.4%). In the case of 85.6 m fish trawl, ODP was maximum for HDPE webbing (70.6%) followed by HDPE float (14.4%), PP rope (6.9%), iron sinker (6.8%) and lead sinker (1.2%).

Among the materials used for construction of 33.4 m cephalopod trawl, ODP was maximum for HDPE webbing (60.2%) followed by HDPE float (22.4%), iron sinker (11.5%), PP rope (4.7%) and lead sinker (1.2%). In the case of 45.6 m cephalopod trawl, ODP was maximum for HDPE webbing (58.1%) followed by HDPE float (28.4%), PP rope (7.1%) and lead sinker (6.4%). In the case of 54.0 m cephalopod trawl, ODP was maximum for HDPE webbing (65.5%) followed by HDPE float (12.2%), iron sinker (11.4%), PP rope (8.5%) and lead sinker (2.3%). In the case of 57.6 m cephalopod trawl, ODP was maximum for HDPE webbing (48.1%) followed by HDPE float (31.7%), PP rope (11.4%) and lead sinker (8.8%).

Among the materials used for construction of 34.2 m shrimp trawl, ODP was maximum for HDPE webbing (45.6%) followed by iron sinker (23.8%), HDPE float (14.7%), PP rope (8.5%) and lead sinker (7.4%). In the case of 39.6 m shrimp trawl, ODP was maximum for HDPE webbing (34.9%) followed by iron sinker (31.8%), PP rope (19.1%), HDPE float (9.2%) and lead sinker (4.9%). In the case of 40.0 m shrimp trawl, ODP was maximum for HDPE webbing (42.4%) followed by iron sinker (22.1%), PP rope (16.4%), HDPE float (16.8%) and lead sinker (2.3%). In the case of 51.0 m shrimp trawl, ODP was maximum for HDPE webbing (31.2%) followed by HDPE float (28.2%), PP rope (20.9%), iron sinker (18.0%) and lead sinker (1.8%). In the case of 58.0 m shrimp trawl, ODP was maximum for HDPE webbing (62.0%) followed by iron sinker (14.1%), PP rope (11.8%), HDPE float (9.3%) and lead sinker (2.9%).

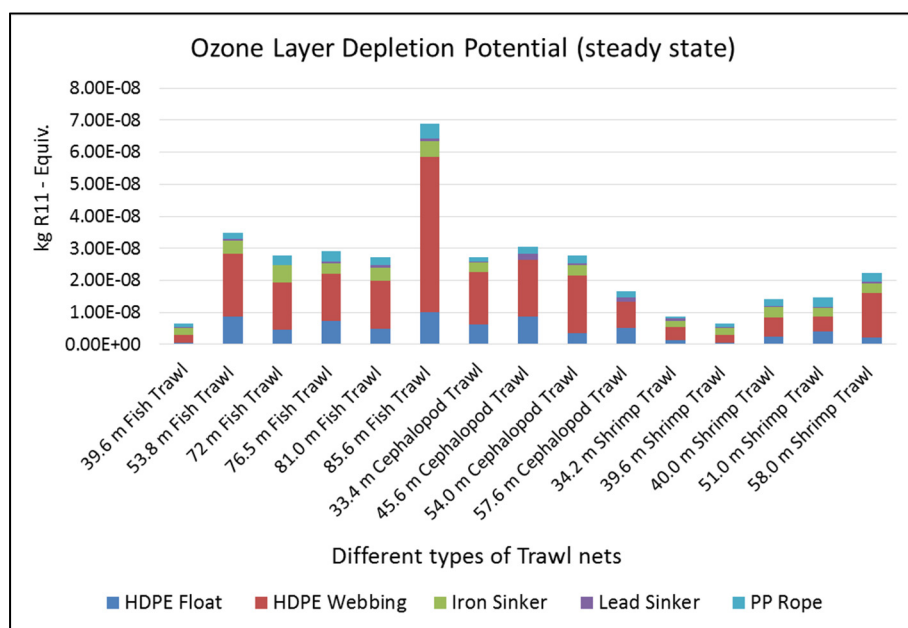

Fig. 5.26 Ozone depletion potential from different trawl nets

5.3.3.7 Photochemical ozone creation potential

Photochemical ozone creation potential (POCP) from different trawl nets viz., fish trawls, cephalopod trawls and shrimp trawls are shown in Fig. 5.27. Among the materials used for construction of 39.6 m fish trawl, POCP was maximum for iron sinker (56.5%) followed by HDPE webbing (17.6%), lead sinker (11.5%), PP rope (9.3%) and HDPE float (5.1%). In the case of 53.8 m fish trawl, POCP was maximum for HDPE webbing (40.1%) followed by iron sinker (30.4%), HDPE float (19.7%), lead sinker (6.2%) and PP rope (3.7%). In the case of 72 m fish trawl, POCP was maximum for iron sinker (44.5%) followed by HDPE webbing (35.8%), HDPE float (12.2%) and PP rope (7.5%). In the case of 76.5 m fish trawl, POCP was maximum for HDPE webbing (36.5%) followed by iron sinker (27.6%), HDPE float (20.3%), PP rope (8.1%) and lead sinker (7.5%). In the case of 81.0 m fish trawl, POCP was maximum for HDPE webbing (37.1%) followed by iron sinker (36.3%),

HDPE float (12.8%), lead sinker (7.4%) and PP rope (6.3%). In the case of 85.6 m fish trawl, POCP was maximum for HDPE webbing (57.5%) followed by iron sinker (19.6%), HDPE float (13.0%), PP rope (5.5%) and lead sinker (4.4%).

Among the materials used for construction of 33.4 m cephalopod trawl, POCP was maximum for HDPE webbing (44.3%) followed by iron sinker (30.0%), HDPE float (18.2%), lead sinker (4.1%) and PP rope (3.3%). In the case of 45.6 m cephalopod trawl, POCP was maximum for HDPE webbing (46.1%) followed by HDPE float (24.9%), lead sinker (23.5%) and PP rope (5.4%). In the case of 54.0 m cephalopod trawl, POCP was maximum for HDPE webbing (47.4%) followed by iron sinker (29.0%), HDPE float (9.8%), lead sinker (7.9%) and PP rope (6.0%). In the case of 57.6 m cephalopod trawl, POCP was maximum for HDPE webbing (35.6%) followed by lead sinker (30.3%), HDPE float (25.9%) and PP rope (8.2%).

Among the materials used for construction of 34.2 m shrimp trawl, POCP was maximum for iron sinker (44.6%) followed by HDPE webbing (24.2%), lead sinker (18.2%), HDPE float (8.6%) and PP rope (4.4%). In the case of 39.6 m shrimp trawl, POCP was maximum for iron sinker (56.5%) followed by HDPE webbing (17.6%), lead sinker (11.5%), PP rope (9.3%) and HDPE float (5.1%). In the case of 40.0 m shrimp trawl, POCP was maximum for iron sinker (47.0%) followed by HDPE webbing (25.7%), HDPE float (11.2%), PP rope (9.7%) and lead sinker (6.4%). In the case of 51.0 m shrimp trawl, POCP was maximum for iron sinker (41.0%) followed by HDPE float (20.2%), HDPE webbing (20.2%), PP rope (13.2%) and lead sinker (5.4%). In the case of 58.0 m shrimp trawl, POCP was maximum for HDPE webbing (42.2%) followed by iron sinker (33.8%), lead sinker (9.2%), PP rope (7.8%) and HDPE float (7.0%).

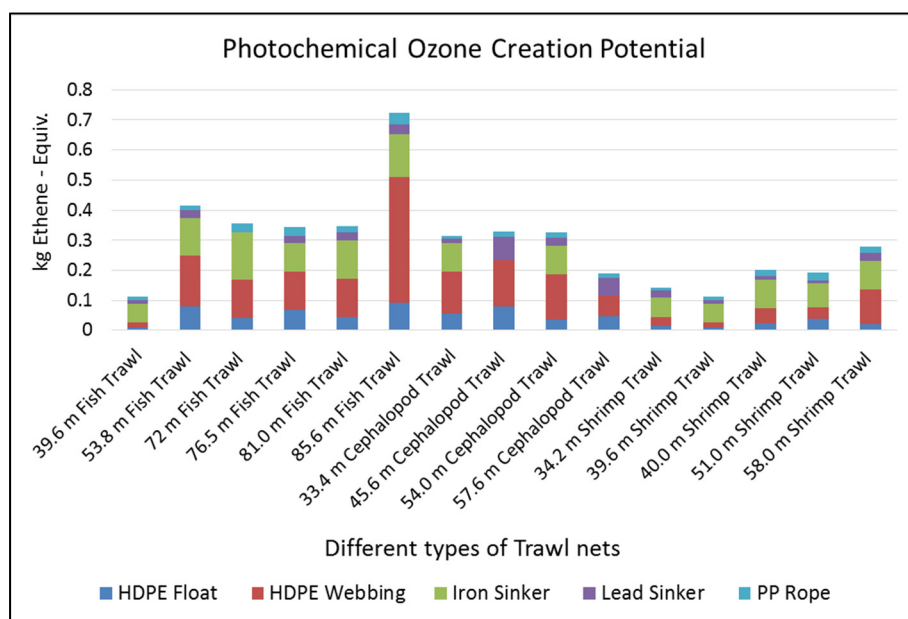

Fig. 5.27 Photochemical ozone creation potential from different trawl nets

5.4 Discussion

Literature pertaining to environmental burdens related to gear production and their use in fisheries are scarce (Ramos *et al.*, 2011, Vázquez-Rowe *et al.*, 2011). A comparison of Global warming potential (GWP) from different categories of trawl nets *viz.*, fish trawls, cephalopod trawls and shrimp trawls are given in Table 5.3. GWP ranged from 214 to 1357 kg CO₂ Equiv. in fish trawls, 282 to 608 kg CO₂ Equiv. in cephalopod trawls and from 214 to 522 kg CO₂ Equiv. in shrimp trawls depending on the quantity of materials used. The GWP in trawls are mainly due to the inorganic emissions to air especially CO₂ mostly derived from HDPE webbing, iron sinker and HDPE floats. In the case of 85.6 m fish trawl, GWP was higher due to the inorganic emissions to air especially CO₂ (93%) which is mostly derived from HDPE webbing followed by iron sinker and HDPE floats.

Table 5.3: Comparison of global warming potential from different trawl nets

Type of trawls	Global warming potential (GWP 100 years) [kg CO ₂ Equiv.]
Fish trawls	214 - 1357
Cephalopod trawls	282 - 608
Shrimp trawls	214 - 522

A comparison of Abiotic depletion potential (fossil) (ADP - fossil) from different categories of trawl nets *viz.*, fish trawls, cephalopod trawls and shrimp trawls are furnished in Table 5.4. ADP - fossil ranged from 3148 to 28992 MJ in fish trawls, 6451 to 12019 MJ in cephalopod trawls and from 3148 to 9731 MJ in shrimp trawls depending on the quantity of materials used. The ADP - fossil in trawls are mainly due to the consumption of non-renewable energy resources especially crude oil (resource), natural gas and hard coal (resource) mostly derived from HDPE webbing and iron sinker. In the case of 85.6 m fish trawl, ADP - fossil was higher due to the non-renewable energy resources especially crude oil (resource) 42.5%, natural gas (28.1%) and hard coal (resource) 26.5%. Of these, 33% crude oil (resource), 21.3% natural gas and 11.9% hard coal (resource) are from HDPE webbing and 9.58% hard coal (resource) from iron sinker.

Table 5.4: Comparison of abiotic depletion potential (fossil) from different trawl nets

Type of trawls	Abiotic depletion potential (fossil) [MJ]
Fish trawl	3148 - 28992
Cephalopod trawl	6451 - 12019
Shrimp trawl	3148 - 9731

Acidification potential (AP) from different categories of trawl nets *viz.*, fish trawls, cephalopod trawls and shrimp trawls are compared in Table 5.5. AP ranged from 1.61 to 9.34 kg SO₂ Equiv. in fish trawls, 2.38 to 4.34 kg SO₂ Equiv. in cephalopod trawls and from 1.61 to 3.78 kg SO₂ Equiv. in shrimp

trawls depending on the quantity of materials used. The AP in trawls are mainly due to the inorganic emissions to air especially Sulphur dioxide and Nitrogen oxides mostly derived from HDPE webbing, iron sinker and HDPE float. In the case of 85.6 m fish trawl, AP was higher due to the inorganic emissions to air especially Sulphur dioxide (77.4%) and Nitrogen oxides (20.6%). Of these, 39.8% Sulphur dioxide were from HDPE webbing, 18.8% Sulphur dioxide from iron sinker, 10.1% Sulphur dioxide from HDPE float and 11.4% Nitrogen oxides were from HDPE webbing.

Table 5.5: Comparison of acidification potential from different trawl nets

Type of trawls	Acidification potential [kg SO ₂ Equiv.]
Fish trawl	1.61 - 9.34
Cephalopod trawl	2.38 - 4.34
Shrimp trawl	1.61 - 3.78

Eutrophication potential (EP) from different categories of trawl nets viz., fish trawls, cephalopod trawls and shrimp trawls are represented in Table 5.6. EP ranged from 0.088 to 0.553 kg Phosphate Equiv. in fish trawls, 0.112 to 0.248 kg Phosphate Equiv. in cephalopod trawls and from 0.088 to 0.213 kg Phosphate Equiv. in shrimp trawls depending on the quantity of materials used. The EP in trawls are mainly due to the inorganic emissions to air especially Nitrogen oxides mostly derived from HDPE webbing, iron sinker and HDPE float. In the case of 85.6 m fish trawl, EP was higher due to the inorganic emissions to air especially Nitrogen oxides (90.3%). Of these, 50% Nitrogen oxides were from HDPE webbing, 21.6% from iron sinker and 12.3% were from HDPE float.

Table 5.6: Comparison of eutrophication potential from different trawl nets

Type of trawls	Eutrophication potential [kg Phosphate Equiv.]
Fish trawl	0.088 - 0.553
Cephalopod trawl	0.112 - 0.248
Shrimp trawl	0.088 - 0.213

A comparison of Marine aquatic ecotoxicity potential (MAETP) from different categories of trawl nets *viz.*, fish trawls, cephalopod trawls and shrimp trawls are represented in Table 5.7. MAETP varied from 207992 to 1258878 kg DCB Equiv. in fish trawls, 237745 to 573052 kg DCB Equiv. in cephalopod trawls and from 207992 to 489680 kg DCB Equiv. in shrimp trawls depending on the quantity of materials used. The MAETP in trawls are mainly due to the inorganic emissions to air especially Hydrogen fluoride, mostly derived from HDPE webbing, iron sinkers and HDPE float. In the case of 85.6 m fish trawl, MAETP was higher due to the inorganic emissions to air especially Hydrogen fluoride (96.6%). Of these, 51.7% Hydrogen fluoride were from HDPE webbing, 24.9% from iron sinkers and 13.6% were from HDPE float.

Table 5.7: Comparison of marine aquatic ecotoxicity potential from different trawl nets

Type of trawls	Marine aquatic ecotoxicity potential [kg DCB Equiv.]
Fish trawl	207992 - 1258878
Cephalopod trawl	237745 - 573052
Shrimp trawl	207992 - 489680

A comparison of Ozone depletion potential (ODP) from different categories of trawl nets *viz.*, fish trawls, cephalopod trawls and shrimp trawls are presented in Table 5.8. ODP varied from 6.57E-09 to 6.90E-08 kg R11 Equiv. in fish trawls, 1.65E-08 to 3.05E-08 kg R11 Equiv. in cephalopod trawls and from 6.57E-09 to 2.23E-08 kg R11 Equiv. in shrimp trawls depending on the quantity of materials used. ODP in trawls were mainly due

to the halogenated organic emissions into the air especially R114 (dichlorotetrafluoroethane) mostly derived from HDPE webbing and HDPE float. In the case of 85.6 m fish trawl, ODP was higher due to the halogenated organic emissions into the air especially R114 (dichlorotetrafluoroethane) (99.6%). 70.4% R114 (dichlorotetrafluoroethane) were from HDPE webbing and 14.4% from HDPE float.

Table 5.8: Comparison of ozone depletion potential from different trawl nets

Type of trawls	Ozone layer depletion potential [kg R11 Equiv.]
Fish trawl	6.57E-09 - 6.90E-08
Cephalopod trawl	1.65E-08 - 3.05E-08
Shrimp trawl	6.57E-09 - 2.23E-08

A comparison of Photochemical ozone creation potential (POCP) from different categories of trawl nets *viz.*, fish trawls, cephalopod trawls and shrimp trawls are furnished in Table 5.9. POCP ranged from 0.112 to 0.725 kg Ethene Equiv. in fish trawls, 0.191 to 0.329kg Ethene Equiv. in cephalopod trawls and from 0.112 to 0.280 kg Ethene Equiv. in shrimp trawls depending on the quantity of materials used. POCP from trawls were due to the inorganic emissions to air especially Sulphur dioxide, Nitrogen oxides and organic emissions especially group Non-methane volatile organic compounds (NMVOC) to air mostly derived from HDPE webbing followed by iron sinkers. In the case of 85.6 m fish trawl, POCP was higher due to the inorganic emissions to air (63.7%) especially Sulphur dioxide (39.9%), Nitrogen oxides (14.9%) and organic emissions especially group NMVOC to air (33.4%). 30.6% Inorganic emissions to air were from HDPE webbing which includes 20.5 % sulphur dioxide and 8.22% Nitrogen oxides emission. 25% Group NMVOC to air were from HDPE webbing. 17.7% inorganic emissions to air were from iron sinkers which includes 9.69% sulphur dioxide emission.

Table 5.9: Comparison of photochemical ozone creation potential from different trawl nets

Type of trawls	Photochemical ozone creation potential [kg Ethene Equiv.]
Fish trawl	0.112 - 0.725
Cephalopod trawl	0.191 - 0.329
Shrimp trawl	0.112 - 0.280

5.5 Conclusion

Detailed study of the different trawl designs showed that, even though HDPE was the main material used for fabrication, the quantity of webbing material used, number of floats and sinkers and other accessories varied drastically with the change in type of trawl design which affected the environmental impact of the gears. The Global Warming Potential (GWP) in trawls are mainly due to the inorganic emissions to air especially CO₂ mostly derived from HDPE webbing, iron sinker and HDPE float. GWP in trawls ranged from 214 to 1357 kg CO₂ Equiv. The Abiotic depletion (fossil) (ADP - fossil) in trawls are mainly due to consumption of non-renewable energy resources especially crude oil (resource), natural gas and hard coal (resource) mostly derived from HDPE webbing and iron sinker. ADP – fossil in trawls ranged from 3148 to 28992 MJ. The Acidification potential (AP) in trawls are mainly due to the inorganic emissions to air especially Sulphur dioxide and Nitrogen oxides mostly derived from HDPE webbing, iron sinker and HDPE float. AP in trawls ranged from 1.61 to 9.34 kg SO₂ Equiv. The Eutrophication potential (EP) in trawls are mainly due to the inorganic emissions to air especially Nitrogen oxides mostly derived from HDPE webbing, iron sinker and HDPE float. EP in trawls ranged from 0.088 to 0.553 kg Phosphate Equiv. The Marine aquatic ecotoxicity potential (MAETP) in trawls are mainly due to the inorganic emissions to air especially Hydrogen fluoride, mostly derived from HDPE webbing, iron sinkers and HDPE float. MAETP in trawls ranged

from 207992 to 1258878 kg DCB Equiv. Ozone depletion potential (ODP) in trawls were mainly due to the halogenated organic emissions into the air especially R114 (dichlorotetrafluoroethane) mostly derived from HDPE webbing and HDPE float. ODP in trawls ranged from 6.57E-09 to 6.90E-08 kg R11Equiv. Photochemical ozone creation potential (POCP) from trawls were due to the inorganic emissions to air especially Sulphur dioxide, Nitrogen oxides and organic emissions especially group Non-methane volatile organic compounds (NMVOC) to air mostly derived from HDPE webbing followed by iron sinkers. POCP in trawls ranged from 0.112 to 0.725 kg Ethene Equiv.

.....**DCB**.....

LIFE CYCLE ASSESSMENT AND CARBON FOOTPRINT OF TRAWL LANDINGS

6.1 Introduction

Mechanised trawling in Indian waters was first started by the vessel S. T. Premier in 1900 off Bombay coast (Chidambaram, 1952; Mukundan & Hameed, 1993). Trawling started with the use of small sized wooden vessels and steel was subsequently used in the vessel building industry. Commercially, trawling was introduced by Indo-Norwegian Project (INP) in 1957 (Pillai *et al.*, 2004). Trawling is an active fishing method which involves shooting, towing and hauling of a bag shaped net through water, to filter out organisms that enter the path of the advancing gear. During trawling, the horizontal opening of the net (spread) is maintained by otter boards, or by the distance between two towing vessels when pair trawling. Single vessel stern trawling is the predominant method and the mouth of the trawl net is kept open by using a pair of otterboards. Though bottom trawling is widely practised, cases where the trawl net is operated off-bottom by adjusting the length of the warp and speed of the vessel was also noticed. Pair trawling was found to be practised in some areas of Ernakulam and Kasaragod, in spite of the ban imposed on the practice. Floats and weights attached to the leading edges of the top and bottom panels (headline and footrope) of the trawl provide the vertical opening. Depth of trawling varies from 8 to 400 m depending on the season, catch and bottom conditions. In trawlers, echosounder is used to find the depth of the fishing area and availability of

fish and the skipper of the boat then selects the ground based on his experience and use of GPS.

First the codend is released, followed by the main body of netting, bridles and otterboards. After ensuring the proper spread of the head ropes and bridles, the required amount of warp is released according to the depth of the ground. The scope ratio generally varies from 1:4 to 1:8 and in certain cases it is more. Subsequently the speed of the vessel is increased to 2.5 knots and above depending on the type of the net used. The impact of trawling depends on the habitat composition and the natural disturbance on the fishing ground (Kaiser *et al.*, 2005). Towing is carried out for 1-3 hours and hauling starts by using the winch. Net and the codend is taken onboard manually or by the rope and pulley system, if the catch is more. Depending on the availability of catch they shift the ground and the process is repeated. The shooting, towing and hauling of the net is done mechanically using winch. Use of net drum for hauling and storing the net have been recently introduced in Kerala especially in very large trawlers. Duration of fishing varies according to the capacity of trawlers. The cruising speed of the vessels normally is 8-12 kn while the trawling speed is normally 2-4 kn, and 5 kn for off-bottom trawling. The number of crew onboard varied depending on the length of the vessel and the duration of the trip.

6.2 Trawl caught species

As India is a tropical country, trawl fishery is of multi-species in nature. Important trawl caught resources along Kerala coast include finfishes such as perches, flat fishes, lizardfishes, croakers, silverbellies, elasmobranchs, pomfrets, big-jawed jumper, catfishes, eels, goatfishes, threadfins, clupeoids, mackerels, carangids, ribbonfishes; crustaceans such as

shrimps and crabs; and molluscs such as cephalopods and gastropods. Marine fish landings from single-day and multi-day trawl operations in Kerala during June 2012 - May 2013 is given in Table 6.1 and Fig. 6.1.

Table 6.1: Estimated marine fish landings in Kerala in single-day trawl and multi-day trawl during June 2012 - May 2013 (in tonnes)

Species groups	Single-day trawl	Multi-day trawl
Elasmobranchs		
Sharks	5.39	192.92
Skates	22.65	299.58
Rays	26.60	208.88
Eels	13.81	385.51
Catfishes	0.98	2.72
Clupeids		
Wolf herring	6.31	56.06
Oil sardine	5970.33	8138.55
Other sardines	5.79	1597.37
Other shads	34.04	118.08
<i>Stolephorus</i> spp.	464.25	6498.62
<i>Thryssa</i> spp.	480.52	2597.08
Other clupeids	462.77	1698.91
Lizard fishes	49.97	9940.85
Half beaks & Full beaks	1.59	2.07
Flying Fishes	0.86	17.05
Perches		
Rock cods	34.54	813.91
Snappers	0.06	23.77
Pig-face breams		22.54
Threadfin breams	170.27	46124.12
Other perches	126.98	1678.31
Goatfishes		878.37
Threadfins	0.17	0.32
Croakers	743.50	1512.72
Ribbon fishes	121.08	8508.16
Carangids		

Horse mackerel	18.57	3219.02
Scads	91.43	21687.84
Leather jackets	1.38	15.54
Other carangids	226.85	2705.49
Silverbellies	356.76	1020.16
Big-jawed jumper	63.91	137.94
Pomfrets		
Black pomfret	4.35	55.66
Silver pomfret	77.99	395.71
Mackerels		
Indian mackerel	116.01	7378.14
Seer fishes		
<i>Scomberomorus commerson</i>	3.62	145.77
<i>Scomberomorus guttatus</i>		0.79
Tunnies		
<i>Euthynnus affinis</i>	0.78	17.18
<i>Auxis</i> spp.		2.78
<i>Katsuwonus pelamis</i>		1.08
Other tunnies		26.64
Bill fishes		
Barracudas	33.86	1917.63
Mulletts	3.60	12.19
Flat fishes		
Halibut		12.23
Flounders	2.81	8.11
Soles	7154.39	7098.73
Crustaceans		
Penaeid prawns	5701.97	16289.31
Non-penaeid prawns		3455.97
Lobsters	1.01	25.39
Crabs	997.09	1165.55
Stomatopods	1115.05	74.47
Molluscs		
Bivalves		
Gastropods	55.09	53.14

Cephalopods		
Squids	81.97	11056.19
Cuttlefish	25.60	13984.29
Octopus	52.86	5630.65
Miscellaneous	51.72	2445.53
Total	24981.12	191355.50

Source: CMFRI (2013b)

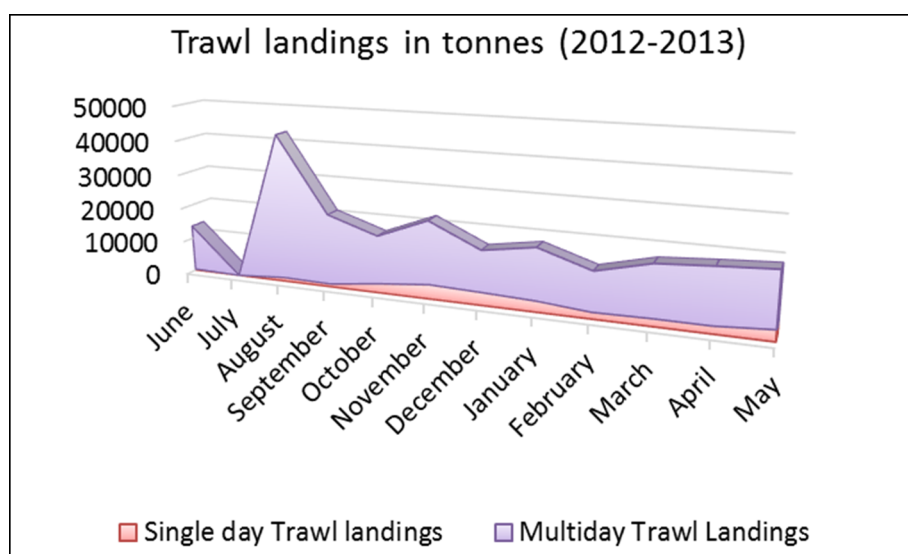

Fig. 6.1. Estimated marine fish landings (month-wise) in Kerala in single-day trawl and multi-day trawl during June 2012 - May 2013 (in tonnes) (Source: CMFRI, 2013b)

Contribution of trawl fisheries from June 2012 to May 2013 formed 26.22% of the total marine fish landings in the Kerala state as per data sourced from Fishery Resources Assessment Division of CMFRI. The overcapacity of the fishing fleet in Kerala has been an increasing problem in the past few decades.

6.3 Materials and methods

Details of life cycle assessment and carbon footprint analysis are given in chapter 2. The categories of trawlers, the types of trawl nets used and the inputs for operation that were used for the study are detailed below:

Category of small trawlers included wooden vessels undertaking single-day operations. Most of the small trawlers were in the size group of 10.66 m L_{OA} . Average duration of operations per day has been 8 h with fuel consumption of 72 litre trip⁻¹. Lub oil consumption per trip was about 0.3 litre. Approximately 200 litres of water and three blocks of ice (60 kg each) were used per trip. A total of six trawl nets namely two numbers of 34.2 m shrimp trawls, two numbers of 39.6 m shrimp trawls and two numbers of 39.6 m fish trawls were used for operations during the period of study. The number of fishing days were 240 per year. Number of single-day trawlers which operated from Kerala were estimated from the number of units undertaking single-day operations sourced from CMFRI database during the period of study.

Category of medium trawlers included both wooden and steel vessels undertaking multi-day operations. Most of the medium trawlers were in the size group of 13.71 m -15.3 m L_{OA} . Average duration of operations per day has been 8 - 9 h with fuel consumption ranging from 192 to 540 litre trip⁻¹ depending on endurance. Lub oil consumption per trip ranged from 0.7 to 2 litres. Approximately 500 to 1250 litres of water and 7- 60 blocks of ice (60 kg each) were used per trip. A total of seven trawl nets namely two numbers of 39.6 m fish trawls, two numbers of 34.2 m and 39.6 m shrimp trawls and one 51.0 m shrimp trawl were used for operations in 13.71 m L_{OA} vessels. A total of 11 trawl nets namely 39.6 m (2 Nos.), 72.0 m (1 No.) and 76.5 m (1 No.) fish trawls; 39.6 m (2 Nos.), 40.0 m (1 No.), 51.0 m (1 No.) and 58.0 m (1 No.) shrimp trawls; 33.4 m (1 No.) and 54.0 m (1 No.) cephalopod trawls were used for operations in 15.3 m L_{OA} vessels during the period of study. The number of fishing trips were 60 to 120 per year.

Category of large trawlers included both wooden and steel vessels undertaking multi-day operations. Most of the large trawlers were in the size

group of 18.9 m, 19.81 m, 21.33 m and 22.86 m L_{OA} . Average duration of operations per day has been 9 - 11 h with fuel consumption ranging from 792 to 1980 litre trip⁻¹ depending on endurance. Lub oil consumption per trip ranged from 2.1 to 5 litres. Approximately 1300 to 2500 litres of water and 75-185 blocks of ice (60 kg each) were used per trip. A total of 11 trawl nets namely 53.8 m (1 No.), 72.0 m (2 Nos.), 76.5 m (2 Nos.) fish trawls; 40.0 m (2 Nos.), 58.0 m (1 No.) shrimp trawls; and 33.4 m (1 No.), 54.0 m (1 No.), 57.6 m (1 No.) cephalopod trawls were used for operations in 18.9 m L_{OA} vessels. Eleven trawl nets namely 53.8 m (2 Nos.), 76.5 m (2 Nos.), 81.0 m (1 No.) fish trawls; 58.0 m (2 Nos.) shrimp trawls; and 45.6 m (1 No.), 54.0 m (1 No.), 57.6 m (1 No.) cephalopod trawls were used for operations in 19.81 m L_{OA} vessels. Eleven to 12 trawl nets namely 53.8 m (3 Nos.), 81.0 m (2 Nos.), 85.6 m (1 No. - only in steel trawlers) fish trawls; 58.0 m (3 Nos.) shrimp trawls; and 45.6 m (3 Nos.) cephalopod trawls were used for operations in 21.33 m L_{OA} vessels. A total of 14 trawl nets namely 53.8 m (3 Nos.), 81.0 m (3 Nos.), 85.6 m (1 No.) fish trawls; 58.0 m (4 Nos.) shrimp trawls; and 45.6 m (3 Nos.) cephalopod trawls were used for operations in 22.86 m L_{OA} vessels, during the period of study. The number of fishing trips by this category of trawlers were 40 to 60 per year.

Category of very large trawlers included only steel vessels undertaking multi-day operations. Very large trawlers in the size group of 24.38 m, 25.9 m and 27.43 m L_{OA} were studied. Average duration of operations per day has been 12 - 14 h with fuel consumption ranging from 3456 to 7560 litre trip⁻¹ depending on endurance. Lub oil consumption per trip ranged from 7 to 11 litres. Approximately 3400 to 5500 litres of water and 250 - 400 blocks of ice were used per trip. A total of 12 trawl nets namely four numbers each of 85.6 m fish trawls, 58.0 m shrimp trawls and 45.6 m cephalopod trawls were used

for operations in 24.38 m L_{OA} vessels. Fifteen trawl nets namely 85.6 m (5 Nos.) fish trawls; 58.0 m (5 Nos.) shrimp trawls; and 45.6 m (5 Nos.) cephalopod trawls were used for operations in 25.9 m L_{OA} vessels. A total of 18 trawl nets mainly six numbers each of 85.6 m fish trawls, 58.0 m shrimp trawls and 45.6 m cephalopod trawls were used for operations in 27.43 m L_{OA} vessels during the period of study. The number of fishing trips in this category of trawlers ranged from 20 to 30 per year.

The goal of this LCA study was to assess the environmental impacts associated with the trawling operations related to Kerala trawl caught marine landings from single-day and multi-day trawl sectors. In this Chapter, LCA per tonne of marine fish landed, as functional unit, has been conducted for the entire trawl fishing system under single-day and multi-day categories. Till date, most of the seafood LCA studies referred to short periods of time, usually, one year, regarding the fishery stage of the process, due mainly to the difficulties in collecting comprehensive data (Vázquez-Rowe *et al.*, 2012b). Major inputs for mechanised trawling operations were fuel, lubricating oil, water and ice for preservation of fish. The operational details of 15 types of trawlers *viz.*, 10.66 m small wooden single-day trawler, 13.71 m medium wooden multi-day trawler, 15.3 m medium wooden multi-day trawler, 18.9 m large wooden multi-day trawler, 19.81 m large wooden multi-day trawler, 21.33 m large wooden multi-day trawler, 13.71 m medium steel multi-day trawler, 15.3 m medium steel multi-day trawler, 18.9 m large steel multi-day trawler, 19.81 m large steel multi-day trawler, 21.33 m large steel multi-day trawler, 22.86 m large steel multi-day trawler, 24.38 m very large steel multi-day trawler, 25.9 m very large steel multi-day trawler and 27.43 m very large steel multi-day trawler were collected on every landing day from June 2012 to May 2013 for the LCA analysis. The system under study comprised the

different stages considered for fish harvesting performed by the mechanised single-day and multi-day trawlers in the trawl fishery (Fig. 6.2), including construction and maintenance of the vessels, construction and maintenance of trawl net and inputs such as diesel, lubricating oil, ice and water used for trawling operations. The product was followed starting from the production of supply materials, such as vessel, nets and inputs for operations, until landing for sale, constituting a “cradle to gate” analysis (Guinée *et al.*, 2001).

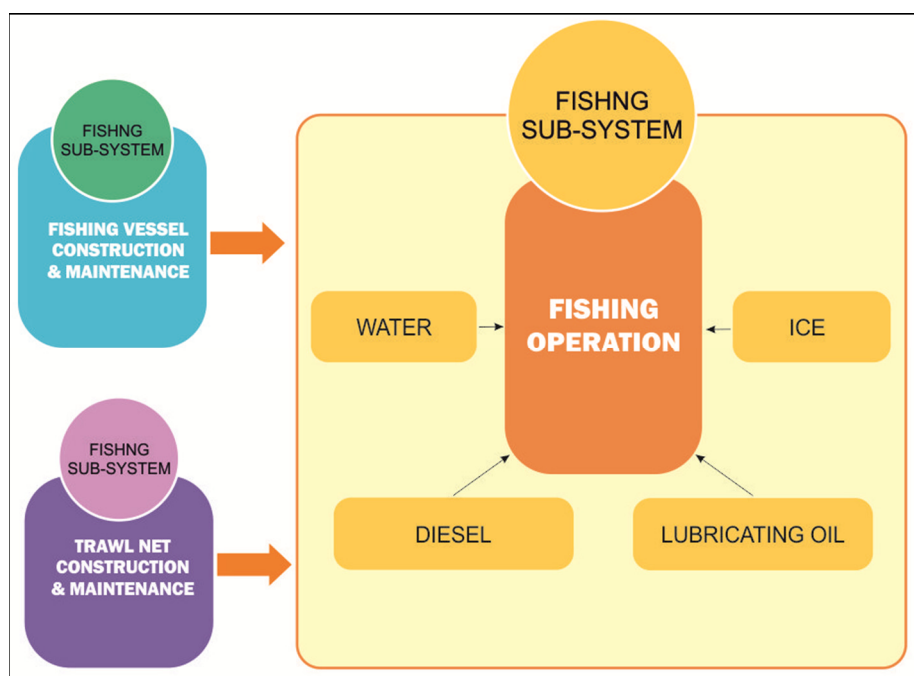

Fig. 6.2. Material inputs for mechanised trawling

6.4 Results

6.4.1 Life cycle inventory

The life cycle inventory were collected through detailed investigations. The life cycle inventories of trawling operations for single-day wooden trawlers and multi-day wooden and steel trawlers per year are shown in Table 6.2 and 6.3.

Table 6.2: Life cycle inventory of trawling operations by wooden vessels per year

Category of trawlers		Trawl nets (No.)	Diesel (litre)	Ice (kg)	Water (litre)	Lub oil (litre)
Small	10.66 m wooden single-day trawler	6	17280	43200	48000	72
Medium	13.71 m wooden multi-day trawler	7	23040	50400	60000	84
	15.3 m wooden multi-day trawler	11	32400	216000	75000	120
Large	18.9 m wooden multi-day trawler	11	47520	270000	78000	126
	19.81 m wooden multi-day trawler	10	62400	360000	90000	150
	21.33 m wooden multi-day trawler	11	69600	432000	96000	180

Table 6.3: Life cycle inventory of trawling operations by steel vessels per year

Category of trawlers		Trawl nets (No.)	Diesel (litre)	Ice (kg)	Water (litre)	Lub oil (litre)
Medium	13.71 m steel multi-day trawler	7	23040	50400	60000	84
	15.3 m steel multi-day trawler	11	32400	216000	75000	120
Large	18.9 m steel multi-day trawler	11	47520	270000	78000	126
	19.81 m steel multi-day trawler	10	62400	360000	90000	150
	21.33 m steel multi-day trawler	12	69600	432000	96000	180
	22.86 m steel multi-day trawler	14	79200	444000	100000	200
Very Large	24.38 m steel multi-day trawler	12	103680	450000	102000	210
	25.9 m steel multi-day trawler	15	131040	460800	105600	216
	27.43 m steel multi-day trawler	18	151200	480000	110000	220

Life cycle assessment values for the mechanised single-day and multi-day trawl fishing operations were scaled up for entire mechanised trawl fishing operation from Kerala using estimates of number of active trawlers in single-day and multi-day category in Kerala, based on data sourced from Fishery Resources Assessment Division of CMFRI, Fishing Vessel Registration Database of the Marine Products Export Development Authority (MPEDA) and from survey conducted under the present study. In the estimates of fish landings, certain sources of uncertainty such as illegal, unreported or unregulated (IUU) fishing activities are difficult to tackle and the potential wastes that can arise during fishing activities such as discards, slipping or offal wastes are difficult to retrieve (Kelleher, 2005; Stratoudakis & Marcalo, 2002). Under such circumstances, Vázquez-Rowe *et al.* (2012b) recommended the use of average previous estimates from published literature. In this study, data on trawler landings for the corresponding sectors, single-day and multi-day operations sourced from CMFRI

database, for the period of investigation, were used for estimation of Global Warming Potential, Abiotic Depletion Potential (fossil), Acidification Potential, Eutrophication Potential, Ozone Depletion Potential, Photochemical Ozone Creation Potential and Marine Aquatic Ecotoxicity Potential per tonne of marine fish landed.

According to Marine Fisheries Census (CMFRI, 2012), a total of 3678 mechanised trawlers are operating in Kerala. About 59% of trawlers have been estimated to be in active operation, based on the results of survey conducted under the present study. Number of single-day trawlers in operation during the period of study has been estimated as 443. Multi-day trawler fleet consisted of 1725 trawlers, with size ranging from 13.71 to 27.43 m L_{OA} . Estimates of fleet size, trip per year and unit trawl operations are shown in Table 6.4.

Table 6.4: Estimates of fleet size, trip per year and unit operations of single-day and multi-day trawler fleets

Category	Number of boats	Trips per year	Unit operations
Single-day trawlers			
10.66 m L_{OA} small wooden trawler	443	240	106320
Sub-total	443	240	106320
Multi-day trawlers			
13.71 m L_{OA} medium wooden trawler	105	120	12600
15.3 m L_{OA} medium wooden trawler	55	60	3300
18.9 m L_{OA} large wooden trawler	64	60	3840
19.81 m L_{OA} large wooden trawler	104	60	6240
21.33 m L_{OA} large wooden trawler	14	60	840
13.71 m L_{OA} medium steel trawler	30	120	3600
15.3 m L_{OA} medium steel trawler	32	60	1920
18.9 m L_{OA} large steel trawler	292	60	17520
19.81 m L_{OA} large steel trawler	639	60	38340
21.33 m L_{OA} large steel trawler	336	60	20160
22.86 m L_{OA} large steel trawler	31	40	1240
24.38 m L_{OA} very large steel trawler	14	30	420
25.9 m L_{OA} very large steel trawler	6	24	144
27.43 m L_{OA} very large steel trawler	3	20	60
Sub-total	1725	20-120	110224
Total	2168	20-240	216544

One unit operation refers to every operation by a craft from its departure from the landing centre/harbour to its return (Sathianandan *et al.*, 2008).

6.4.2 Life cycle impact assessment

Under Life Cycle Assessment of trawling operations, seven impact categories *viz.*, Global warming potential (GWP), Abiotic depletion potential (fossil) (ADP- fossil), Acidification potential (AP), Eutrophication potential (EP), Ozone depletion potential (ODP), Photochemical ozone creation potential (POCP) and Marine aquatic ecotoxicity potential (MAETP) were considered (Fig. 6.3 to 6.9). GaBi-6 was the software used.

6.4.2.1 Global warming potential

Single-day trawlers

Among the materials used for 10.66 m small wooden single-day trawler operation, Global Warming Potential (GWP) was maximum for diesel (97.4%) followed by trawl nets (2.3%), lubricants (0.1%) and ice (0.1%). GWP was negative due to wood used for construction in 10.66 m wooden vessels (-2164.55 kg CO₂ Equiv.).

Multi-day trawlers

Among the materials used for 13.71 m medium wooden multi-day trawler operation, GWP was maximum for diesel (97.5%), followed by trawl nets (2.3%), lubricants (0.1%) and ice (0.1%). GWP was negative due to wood used for construction in 13.71 m wooden vessels (-2952.55 kg CO₂ Equiv.). In the case of 15.3 m medium wooden multi-day trawler operation, GWP was maximum for diesel (95.3%) followed by trawl nets (4.2%), ice (0.2%) and lubricants (0.1%). GWP was negative due to wood used for

construction in 15.3 m wooden vessels (-3297.17 kg CO₂ Equiv.). In 18.9 m large wooden multi-day trawler operation, GWP was maximum for diesel (95.8%) followed by trawl nets (4.0%), ice (0.2%) and lubricants (0.1%). GWP was negative due to wood used for construction in 18.9 m wooden vessels (-3780.52 kg CO₂ Equiv.). In the case of 19.81 m large wooden multi-day trawler operation, GWP was maximum for diesel (96.9%) followed by trawl nets (2.7%), ice (0.2%) and lubricants (0.1%). GWP was negative due to wood used for construction in 19.81 m wooden vessels (-3908.09 kg CO₂ Equiv.). In 21.33 m large wooden multi-day trawler operation, GWP was maximum for diesel (96.8%) followed by trawl nets (3.0%), ice (0.2%) and lubricants (0.1%). GWP was negative due to wood used for construction in 21.33 m wooden vessels (-4328.13 kg CO₂ Equiv.).

Among the materials used for 13.71 m medium steel multi-day trawler operation, GWP was maximum for diesel (94.1%) followed by vessel (3.5%), trawl nets (2.1%), lubricants (0.1%) and ice (0.1%). In the case of 15.3 m medium steel multi-day trawler operation, GWP was maximum for diesel (92.6%) followed by trawl nets (4.1%), vessel (2.9%), ice (0.2%) and lubricants (0.1%). In 18.9 m large steel multi-day trawler operation, GWP was maximum for diesel (93.3%) followed by trawl nets (4.0%), vessel (2.5%), ice (0.2%) and lubricants (0.1%). In the case of 19.81 m large steel multi-day trawler operation, GWP was maximum for diesel (94.9%) followed by trawl nets (2.7%), vessel (2.1%), ice (0.2%) and lubricants (0.1%). In the case of 21.33 m large steel multi-day trawler operation, GWP was maximum for diesel (94.3%) followed by trawl nets (3.4%), vessel (1.9%), ice (0.2%) and lubricants (0.1%). In 22.86 m large steel multi-day trawler operation, GWP was maximum for diesel (94.5%) followed by trawl nets (3.5%), vessel

(1.8%), ice (0.2%) and lubricants (0.1%). In the case of 24.38 m very large steel multi-day trawler operation, GWP was maximum for diesel (95.6%) followed by trawl nets (2.7%), vessel (1.5%), ice (0.2%) and lubricants (0.1%). In the case of 25.9 m very large steel multi-day trawler operation, GWP was maximum for diesel (95.9%) followed by trawl nets (2.7%), vessel (1.2%), ice (0.1%) and lubricants (0.1%). In the case of 27.43 m very large steel multi-day trawler operation, GWP was maximum for diesel (95.7%) followed by trawl nets (2.8%), vessel (1.3%) and ice (0.1%).

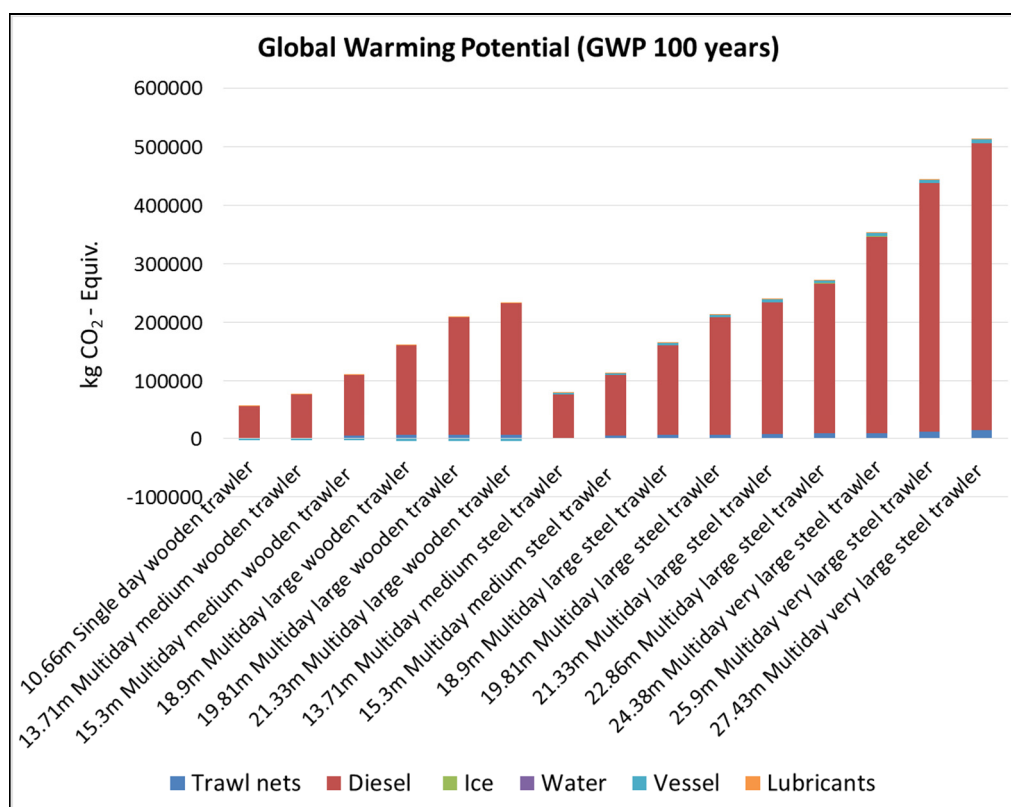

Fig. 6.3 Global warming potential for trawler operations, for different size categories

A comparison of Global warming potential from single-day and multi-day trawler sectors in Kerala are given in Table 6.5.

Table 6.5: Global warming potential (GWP 100 years) in single-day and multi-day trawler sectors in Kerala

Category	kg CO ₂ Equiv.
<i>Single-day trawlers</i>	
Wooden trawlers	-9.59E+05
Trawl nets	5.98E+05
Diesel	2.49E+07
Lubricants	3.41E+04
Ice	2.33E+04
Water	1.20E+04
Sub-total	2.46E+07
<i>Multi-day trawlers</i>	
Steel trawlers	6.09E+06
Wooden trawlers	-1.20E+06
Trawl nets	1.07E+07
Diesel	3.21E+08
Lubricants	2.69E+05
Ice	6.86E+05
Water	8.40E+04
Sub-total	3.38E+08
Total	3.62E+08

6.4.2.2 Abiotic depletion potential (fossil)

Single-day trawlers

Among the materials used for 10.66 m small wooden single-day trawler operation, ADP - fossil was maximum for diesel (94.5%) followed by trawl nets (2.9%), vessel (2%), lubricants (0.5%) and ice (0.1%).

Multi-day trawlers

Among the materials used for 13.71 m medium wooden multi-day trawler operation, ADP - fossil was maximum for diesel (94.8%) followed by

trawl nets (2.8%), vessel (1.8%), lubricants (0.5%) and ice (0.1%). In the case of 15.3 m medium wooden multi-day trawler operation, ADP - fossil was maximum for diesel (91.7%) followed by trawl nets (6.2%), vessel (1.5%), lubricants (0.4%) and ice (0.2%). In 18.9 m large wooden multi-day trawler operation, ADP - fossil was maximum for diesel (92.3%) followed by trawl nets (5.9%), vessel (1.3%), lubricants (0.3%) and ice (0.2%). In the case of 19.81 m large wooden multi-day trawler operation, ADP - fossil was maximum for diesel (93.9%) followed by trawl nets (11.9%), vessel (1.1%), lubricants (0.3%) and ice (0.2%). In the case of 21.33 m large wooden multi-day trawler operation, ADP - fossil was maximum for diesel (93.8%) followed by trawl nets (4.6%), vessel (1.1%), lubricants (0.3%) and ice (0.2%).

Among the materials used for 13.71 m medium steel multi-day trawler operation, ADP - fossil was maximum for diesel (92.0%) followed by vessel (4.7%), trawl nets (2.7%), lubricants (0.4%) and ice (0.1%). In the case of 15.3 m medium steel multi-day trawler operation, ADP - fossil was maximum for diesel (89.6%) followed by trawl nets (5.9%), vessel (3.8%), lubricants (0.4%) and ice (0.2%). In 18.9 m large steel multi-day trawler operation, ADP - fossil was maximum for diesel (90.4%) followed by trawl nets (5.7%), vessel (3.3%), lubricants (0.3%) and ice (0.2%). In the case of 19.81 m large steel multi-day trawler operation, ADP - fossil was maximum for diesel (92.4%) followed by trawl nets (4.5%), vessel (2.7%), lubricants (0.3%) and ice (0.2%). In 21.33 m large steel multi-day trawler operation, ADP - fossil was maximum for diesel (91.5%) followed by trawl nets (5.5%), vessel (2.5%), lubricants (0.3%) and ice (0.2%). In the case of 22.86 m large steel multi-day trawler operation, ADP - fossil was maximum for diesel (91.7%) followed by trawl nets (5.6%), vessel (2.3%), lubricants (0.3%) and ice (0.2%). In 24.38 m

very large steel multi-day trawler operation, ADP - fossil was maximum for diesel (93.1%) followed by trawl nets (4.7%), vessel (1.9%), lubricants (0.2%) and ice (0.1%). In the case of 25.9 m very large steel multi-day trawler operation, ADP - fossil was maximum for diesel (93.4%) followed by trawl nets (4.7%), vessel (1.6%), lubricants (0.2%) and ice (0.1%). In 27.43 m very large steel multi-day trawler operation, ADP - fossil was maximum for diesel (93.3%) followed by trawl nets (4.8%), vessel (1.6%), lubricants (0.2%) and ice (0.1%).

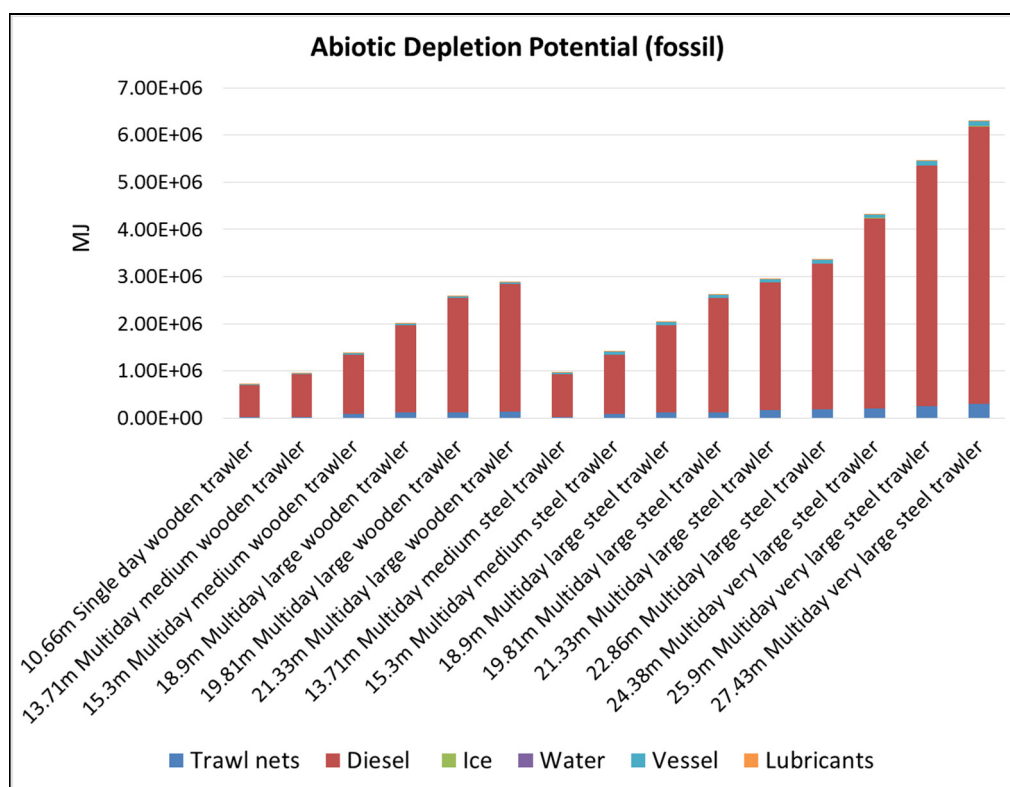

Fig. 6.4 Abiotic depletion potential (fossil) for trawler operations, for different size categories

A comparison of ADP - fossil from single-day and multi-day trawler sectors in Kerala are given in Table 6.6.

Table 6.6: Abiotic depletion potential (fossil) in single-day and multi-day trawler sectors in Kerala

Category	MJ
<i>Single-day trawlers</i>	
Wooden trawlers	6.31E+06
Trawl nets	9.05E+06
Diesel	2.98E+08
Lubricants	1.63E+06
Ice	2.29E+05
Water	1.15E+05
Sub-total	3.15E+08
<i>Multi-day trawlers</i>	
Steel trawlers	9.65E+07
Wooden trawlers	7.88E+06
Trawl nets	2.08E+08
Diesel	3.84E+09
Lubricants	1.29E+07
Ice	6.74E+06
Water	8.00E+05
Sub-total	4.17E+09
Total	4.49E+09

6.4.2.3 Acidification potential

Single-day trawlers

Among the materials used for 10.66 m small wooden single-day trawler operation, Acidification potential (AP) was maximum for diesel (90.8%) followed by trawl nets (5.8%), vessel (3.2%) and lubricants (0.1%).

Multi-day trawlers

Among the materials used for 13.71 m medium wooden multi-day trawler operation, AP was maximum for diesel (91.3%) followed by trawl nets

(5.6%), vessel (2.9%) and lubricants (0.1%). In the case of 15.3 m medium wooden multi-day trawler operation, AP was maximum for diesel (87.5%) followed by trawl nets (9.7%), vessel (2.4%), lubricants (0.1%) and ice (0.1%). In 18.9 m large wooden multi-day trawler operation, AP was maximum for diesel (88.7%) followed by trawl nets (9%), vessel (2.1%), lubricants (0.1%) and ice (0.1%). In the case of 19.81 m large wooden multi-day trawler operation, AP was maximum for diesel (91.2%) followed by trawl nets (6.7%), vessel (1.8%), lubricants (0.1%) and ice (0.1%). In 21.33 m large wooden multi-day trawler operation, AP was maximum for diesel (91.0%) followed by trawl nets (6.9%), vessel (1.8%), lubricants (0.1%) and ice (0.1%).

Among the materials used for 13.71 m medium steel multi-day trawler operation, AP was maximum for diesel (86.6%) followed by vessel (8%), trawl nets (5.3%) and lubricants (0.1%). In the case of 15.3 m medium steel multi-day trawler operation, AP was maximum for diesel (83.9%) followed by trawl nets (9.4%), vessel (6.4%), lubricants (0.1%) and ice (0.1%). In 18.9 m large steel multi-day trawler operation, AP was maximum for diesel (85.5%) followed by trawl nets (8.7%), vessel (5.6%), lubricants (0.1%) and ice (0.1%). In the case of 19.81 m large steel multi-day trawler operation, AP was maximum for diesel (88.6%) followed by trawl nets (6.6%), vessel (4.6%), lubricants (0.1%) and ice (0.1%). In 21.33 m large steel multi-day trawler operation, AP was maximum for diesel (87.6%) followed by trawl nets (7.9%), vessel (4.3%), lubricants (0.1%) and ice (0.1%). In the case of 22.86 m large steel multi-day trawler operation, AP was maximum for diesel (87.8%) followed by trawl nets (8.0%), vessel (3.9%), lubricants (0.1%) and ice

(0.1%). In 24.38 m very large steel multi-day trawler operation, AP was maximum for diesel (90.2%) followed by trawl nets (6.4%), vessel (3.2%), lubricants (0.1%) and ice (0.1%). In 25.9 m very large steel multi-day trawler operation, AP was maximum for diesel (90.7%) followed by trawl nets (6.4%), vessel (2.8%), lubricants (0.1%) and ice (0.1%). In the case of 27.43 m very large steel multi-day trawler operation, AP was maximum for diesel (90.5%) followed by trawl nets (6.7%), vessel (2.8%) and ice (0.1%).

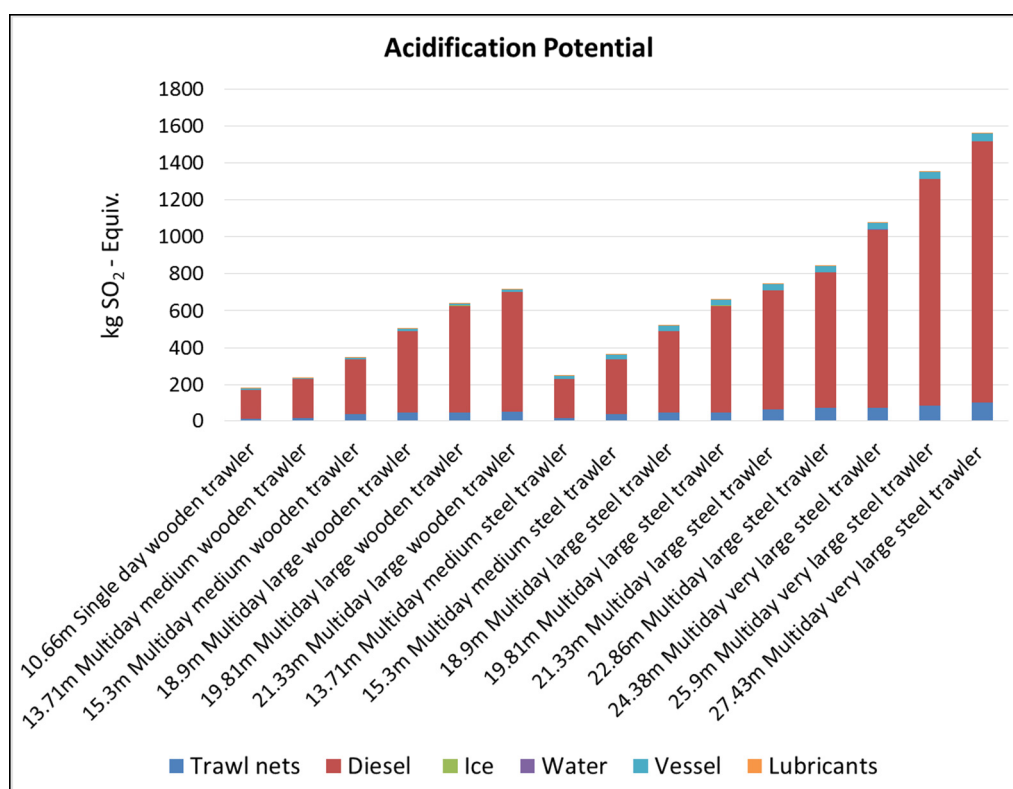

Fig. 6.5 Acidification potential for trawler operations, for different size categories

A comparison of AP from single-day and multi-day trawler sectors in Kerala are given in Table 6.7.

Table 6.7: Acidification potential in single-day and multi-day trawler sectors in Kerala

Category	kg SO ₂ Equiv.
<i>Single-day trawlers</i>	
Wooden trawlers	2.49E+03
Trawl nets	4.62E+03
Diesel	7.16E+04
Lubricants	1.07E+02
Ice	3.85E+01
Water	2.01E+01
Sub-total	7.89E+04
<i>Multi-day trawlers</i>	
Steel trawlers	4.18E+04
Wooden trawlers	3.21E+03
Trawl nets	7.74E+04
Diesel	9.23E+05
Lubricants	8.48E+02
Ice	1.13E+03
Water	1.40E+02
Sub-total	1.05E+06
Total	1.13E+06

6.4.2.4 Eutrophication potential

Single-day trawlers

Among the materials used for 10.66 m small wooden single-day trawler operation, EP was maximum for diesel (88.1%) followed by trawl nets (6.4%), vessel (5.0%), lubricants (0.2%), ice (0.2%) and water (0.1%).

Multi-day trawlers

Among the materials used for 13.71 m medium wooden multi-day trawler operation, EP was maximum for diesel (88.5%) followed by trawl nets

(6.2%), vessel (4.9%), lubricants (0.2%), ice (0.2%) and water (0.1%). In the case of 15.3 m medium wooden multi-day trawler operation, EP was maximum for diesel (83.9%) followed by trawl nets (11.3%), vessel (4.0%), lubricants (0.2%), ice (0.5%) and water (0.1%). In 18.9 m large wooden multi-day trawler operation, EP was maximum for diesel (85.3%) followed by trawl nets (10.5%), vessel (3.6%), ice (0.4%), lubricants (0.1%) and water (0.1%). In the case of 19.81 m large wooden multi-day trawler operation, EP was maximum for diesel (88.5%) followed by trawl nets (8.0%), vessel (3%), lubricants (0.1%), ice (0.4%) and water (0.1%). In 21.33 m large wooden multi-day trawler operation, EP was maximum for diesel (88%) followed by trawl nets (7.9%), vessel (3.4%), lubricants (0.1%), ice (0.5%) and water (0.1%).

Among the materials used for 13.71 m medium steel multi-day trawler operation, EP was maximum for diesel (83.8%) followed by vessel (10%), trawl nets (5.8%), lubricants (0.2%), ice (0.2%) and water (0.1%). In the case of 15.3 m medium steel multi-day trawler operation, EP was maximum for diesel (80.4%) followed by trawl nets (11%), vessel (8.0%), ice (0.5%), lubricants (0.2%) and water (0.1%). In 18.9 m large steel multi-day trawler operation, EP was maximum for diesel (82.2%) followed by trawl nets (10.2%), vessel (7.0%), ice (0.4%), lubricants (0.1%) and water (0.1%). In the case of 19.81 m large steel multi-day trawler operation, EP was maximum for diesel (86.0%) followed by trawl nets (7.5%), vessel (5.8%), ice (0.4%), lubricants (0.1%) and water (0.1%). In 21.33 m large steel multi-day trawler operation, EP was maximum for diesel (84.8%) followed by trawl nets (9.2%), vessel (5.4%), ice (0.5%), lubricants (0.1%) and water (0.1%). In the case of 22.86 m large steel multi-day trawler operation, EP was maximum for diesel (85.2%) followed by trawl nets (9.3%), vessel (5.0%), ice (0.4%), lubricants

(0.1%) and water (0.1%). In 24.38 m very large steel multi-day trawler operation, EP was maximum for diesel (87.9%) followed by trawl nets (7.5%), vessel (4.1%), ice (0.3%) and lubricants (0.1%). In the case of 25.9 m very large steel multi-day trawler operation, EP was maximum for diesel (88.6%) followed by trawl nets (7.4%), vessel (3.6%), ice (0.3%) and lubricants (0.1%). In 27.43 m very large steel multi-day trawler operation, EP was maximum for diesel (88.4%) followed by trawl nets (7.7%), vessel (3.5%), ice (0.2%) and lubricants (0.1%).

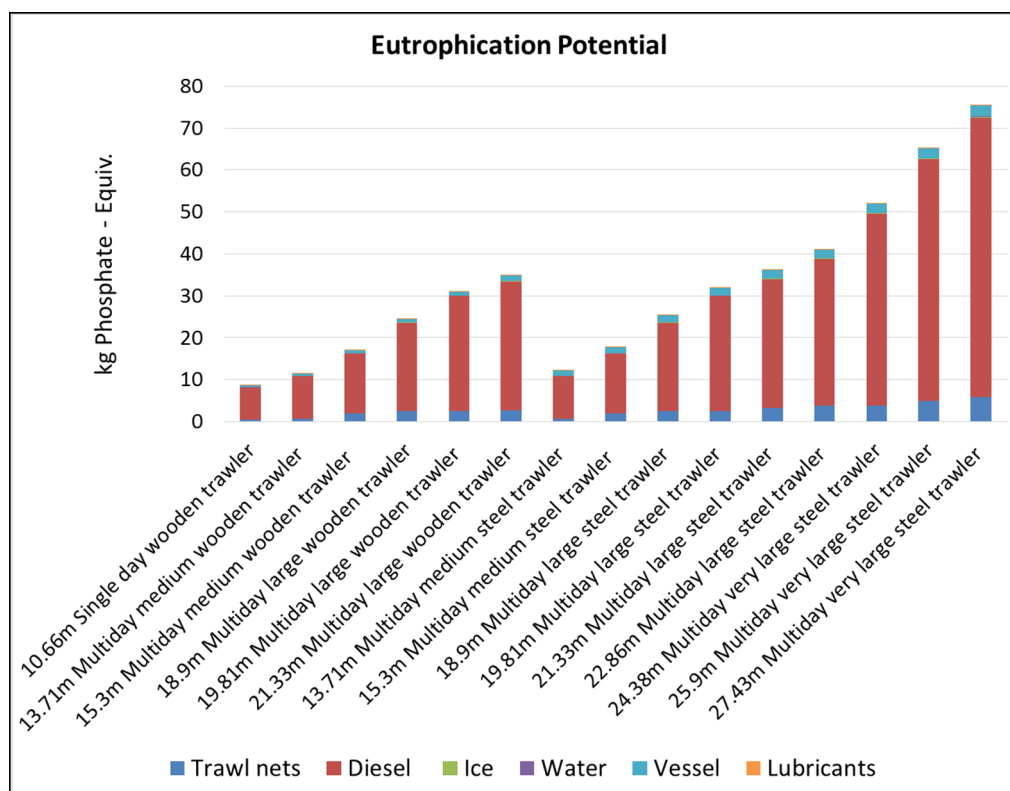

Fig. 6.6 Eutrophication potential for trawler operations, for different size categories

A comparison of EP from single-day and multi-day trawler sectors in Kerala are given in Table 6.8.

Table 6.8: Eutrophication potential in single-day and multi-day trawler sectors in Kerala

Category	kg Phosphate Equiv.
<i>Single-day trawlers</i>	
Wooden trawlers	1.91E+02
Trawl nets	2.45E+02
Diesel	3.38E+03
Lubricants	7.09E+00
Ice	7.34E+00
Water	5.21E+00
Sub-total	3.83E+03
<i>Multi-day trawlers</i>	
Steel trawlers	2.57E+03
Wooden trawlers	2.68E+02
Trawl nets	4.36E+03
Diesel	4.35E+04
Lubricants	5.60E+01
Ice	2.17E+02
Water	3.63E+01
Sub-total	5.10E+04
Total	5.49E+04

6.4.2.5 Marine aquatic ecotoxicity potential

Single-day trawlers

Among the materials used for 10.66 m small wooden single-day trawler operation, MAETP was maximum for trawl nets (43.9%), followed by diesel (33.5%), vessel (22.1%), lubricants (0.2%) ice (0.2%) and water (0.1%).

Multi-day trawlers

Among the materials used for 13.71 m medium wooden multi-day trawler operation, MAETP was maximum for trawl nets (43.4%) followed by

diesel (34.4%), vessel (21.7%), lubricants (0.2%), ice (0.2%) and water (0.1%). In the case of 15.3 m medium wooden multi-day trawler operation, MAETP was maximum for trawl nets (60.5%) followed by diesel (24.8%), vessel (14.1%), ice (0.4%), lubricants (0.1%) and water (0.1%). In 18.9 m large wooden multi-day trawler operation, MAETP was maximum for trawl nets (59.4%) followed by diesel (26.8%), vessel (13.4%), ice (0.3%) and lubricants (0.1%). In the case of 19.81 m large wooden multi-day trawler operation, MAETP was maximum for trawl nets (52.2%) followed by diesel (33.5%), vessel (13.6%), ice (0.4%) and lubricants (0.1%). In 21.33 m large wooden multi-day trawler operation, MAETP was maximum for trawl nets (51.8%) followed by diesel (32.8%), vessel (14.8%), ice (0.5%) and lubricants (0.1%).

Among the materials used for 13.71 m medium steel multi-day trawler operation, MAETP was maximum for trawl nets (36.9%) followed by vessel (33.7%), diesel (29.1%), ice (0.1%), water (0.1%) and lubricants (0.1%). In the case of 15.3 m medium steel multi-day trawler operation, MAETP was maximum for trawl nets (55.4%) followed by diesel (22.6%), vessel (21.6%), ice (0.3%), water (0.1%) and lubricants (0.1%). In 18.9 m large steel multi-day trawler operation, MAETP was maximum for trawl nets (55%) followed by diesel (24.7%), vessel (20.2%), ice (0.3%) and lubricants (0.1%). In the case of 19.81 m large steel multi-day trawler operation, MAETP was maximum for trawl nets (48.4%) followed by diesel (31.0%), vessel (20.1%), ice (0.4%) and lubricants (0.1%). In 21.33 m large steel multi-day trawler operation, MAETP was maximum for trawl nets (53.9%) followed by diesel (28.4%), vessel (17.2%), ice (0.4%) and lubricants (0.1%). In the case of 22.86 m large steel multi-day trawler operation, MAETP was maximum for trawl nets (54.9%) followed by diesel (28.6%), vessel (16.0%), ice (0.4%) and lubricants (0.1%).

In 24.38 m very large steel multi-day trawler operation, MAETP was maximum for trawl nets (50.4%) followed by diesel (34.0%), vessel (15.1%), ice (0.3%) and lubricants (0.1%). In the case of 25.9 m very large steel multi-day trawler operation, MAETP was maximum for trawl nets (51.3%) followed by diesel (35.0%), vessel (13.5%), ice (0.3%) and lubricants (0.1%). In 27.43 m very large steel multi-day trawler operation, MAETP was maximum for trawl nets (52.3%) followed by diesel (34.3%), vessel (13.0%), ice (0.2%) and lubricants (0.1%).

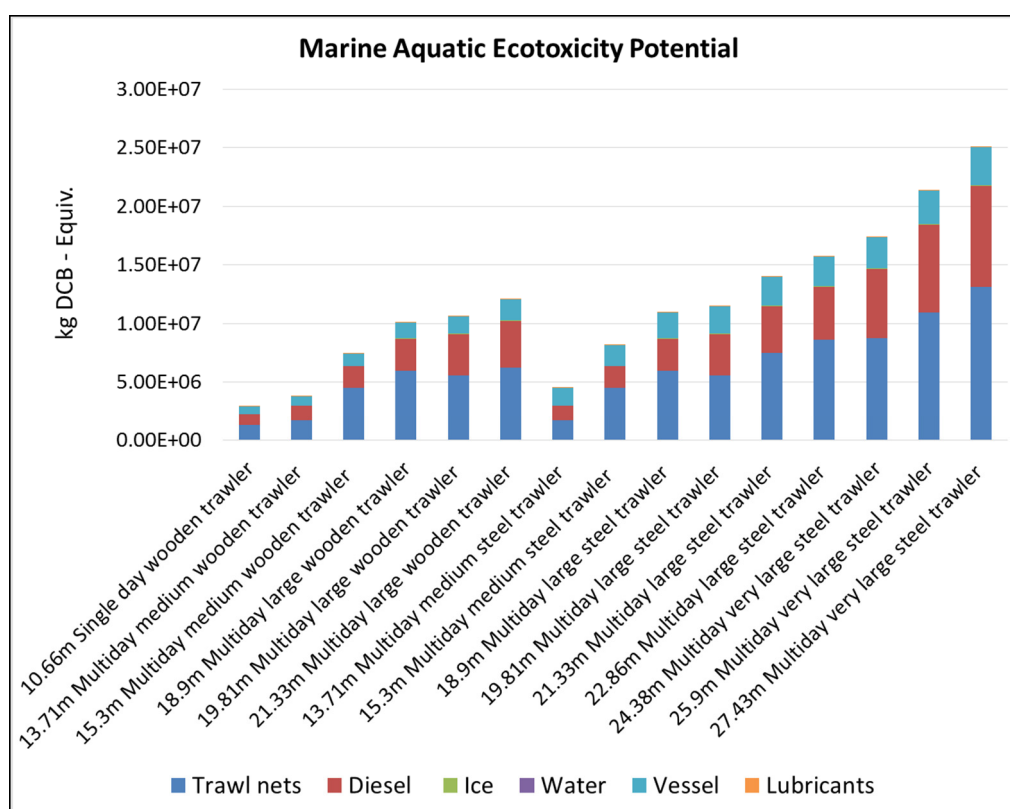

Fig. 6.7 Marine aquatic ecotoxicity potential for trawler operations, for different size categories

A comparison of MAETP from single-day and multi-day trawler sectors in Kerala are given in Table 6.9.

Table 6.9: Marine aquatic ecotoxicity potential in single-day and multi-day trawler sectors in Kerala

Category	kg DCB Equiv.
<i>Single-day trawlers</i>	
Wooden trawlers	2.89E+08
Trawl nets	5.73E+08
Diesel	4.36E+08
Lubricants	2.19E+06
Ice	2.46E+06
Water	1.20E+06
Sub-total	1.30E+09
<i>Multi-day trawlers</i>	
Steel trawlers	3.17E+09
Wooden trawlers	4.06E+08
Trawl nets	9.99E+09
Diesel	5.63E+09
Lubricants	1.73E+07
Ice	7.26E+07
Water	8.38E+06
Sub-total	1.93E+10
Total	2.06E+10

6.4.2.6 Ozone depletion potential

Single-day trawlers

Among the materials used for 10.66 m small wooden single-day trawler operation, Ozone depletion potential (ODP) was maximum for vessel (68.7%) followed by diesel (15.6%) trawl nets (13.8%), ice (1.3%), water (0.4%) and lubricants (0.3%).

Multi-day trawlers

Among the materials used for 13.71 m medium wooden multi-day trawler operation, ODP was maximum for vessel (78.2%) followed by diesel

(10.9%) trawl nets (9.6%), ice (0.8%), water (0.3%) and lubricants (0.2%). In the case of 15.3 m medium wooden multi-day trawler operation, Ozone depletion potential was maximum for vessel (69.6%) followed by trawl nets (17.9%), diesel (9.2%), ice (2.0%), water (0.2%) and lubricants (0.2%). In 18.9 m large wooden multi-day trawler operation, Ozone depletion potential was maximum for vessel (72.1%) followed by trawl nets, (17.3%), diesel (8.7%), ice (1.6%), water (0.1%) and lubricants (0.1%). In the case of 19.81 m large wooden multi-day trawler operation, ODP was maximum for vessel (73.6%) followed by trawl nets (14.9%), diesel (9.6%), ice (1.8%), water (0.1%) and lubricants (0.1%). In 21.33 m large wooden multi-day trawler operation, ODP was maximum for vessel (76.0%) followed by trawl nets (13.6%), diesel (8.5%), ice (1.7%), water (0.1%) and lubricants (0.1%).

Among the materials used for 13.71 m medium steel multi-day trawler operation, ODP was maximum for diesel (37.9%) followed by trawl nets (33.5%), vessel (24.4%), ice (2.7%), water (1.0%) and lubricants (0.6%). In the case of 15.3 m medium steel multi-day trawler operation, ODP was maximum for trawl nets (52.9%) followed by diesel (25.8%), vessel (14.7%), ice (5.6%), water (0.6%) and lubricants (0.4%). In 18.9 m large steel multi-day trawler operation, ODP was maximum for trawl nets (53.9%) followed by diesel (27.0%), vessel (13.3%), ice (5%), water (0.4%) and lubricants (0.3%). In the case of 19.81 m large steel multi-day trawler operation, ODP was maximum for trawl nets (49%) followed by diesel (31.8%), vessel (12.4%), ice (5.9%), water (0.4%) and lubricants (0.3%). In 21.33 m large steel multi-day trawler operation, ODP was maximum for trawl nets (55.0%) followed by diesel (28.3%), vessel (10.4%), ice (5.7%), water (0.4%) and lubricants (0.3%). In the case of 22.86 m large steel multi-day trawler operation, ODP was maximum for trawl nets (55.5%) followed by diesel (28.8%), vessel

(9.7%), ice (5.2%), water (0.4%) and lubricants (0.3%). In 24.38 m very large steel multi-day trawler operation, ODP was maximum for trawl nets (53.5%) followed by diesel (32.5%), vessel (8.9%), ice (4.6%), water (0.3%) and lubricants (0.3%). In the case of 25.9 m very large steel multi-day trawler operation, ODP was maximum for trawl nets (54.3%) followed by diesel (33.3%), vessel (8.3%), ice (3.8%), water (0.3%) and lubricants (0.2%). In 27.43 m very large steel multi-day trawler operation, ODP was maximum for trawl nets (55.6%) followed by diesel (32.8%), vessel (7.8%), ice (3.4%), water (0.2%) and lubricants (0.2%).

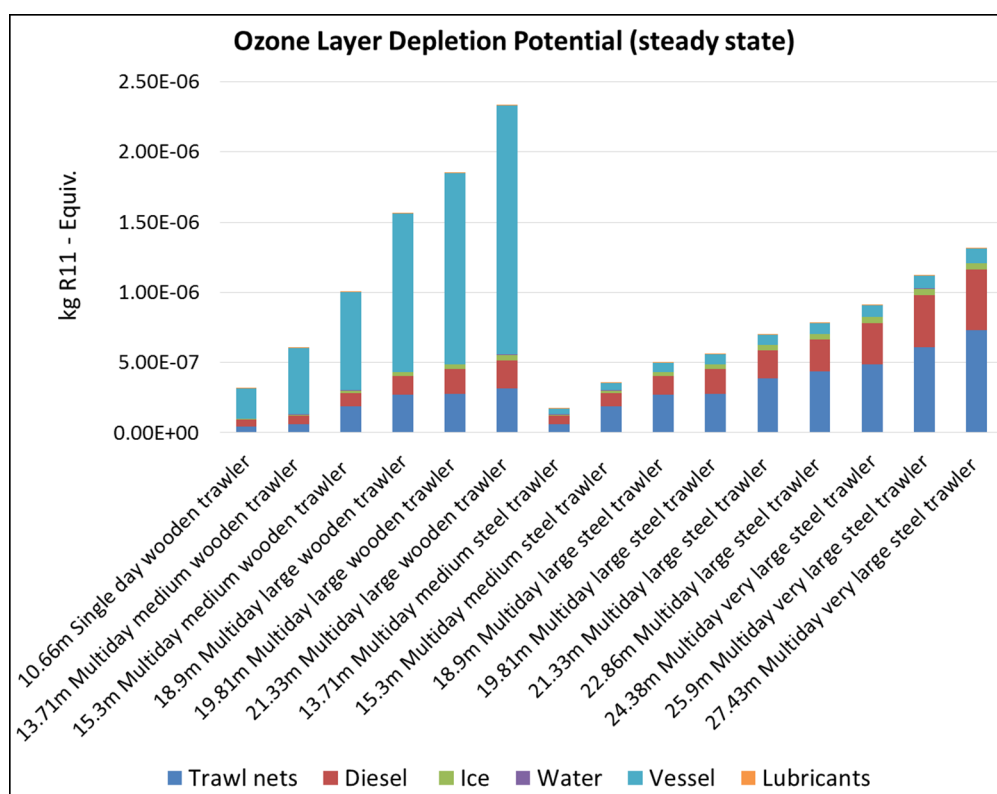

Fig. 6.8 Ozone depletion potential for trawler operations, for different size categories

A comparison of ODP from single-day and multi-day trawler sectors in Kerala are given in Table 6.10.

Table 6.10: Ozone depletion potential in single-day and multi-day trawler sectors in Kerala

Category	kg R11 Equiv.
<i>Single-day trawlers</i>	
Wooden trawlers	9.61E-05
Trawl nets	1.93E-05
Diesel	2.18E-05
Lubricants	4.01E-07
Ice	1.77E-06
Water	5.86E-07
Sub-total	1.40E-04
<i>Multi-day trawlers</i>	
Steel trawlers	9.57E-05
Wooden trawlers	3.27E-04
Trawl nets	4.85E-04
Diesel	2.81E-04
Lubricants	3.17E-06
Ice	5.22E-05
Water	4.09E-06
Sub-total	1.25E-03
Total	1.39E-03

6.4.2.7 Photochemical ozone creation potential

Single-day trawlers

Among the materials used for 10.66 m small wooden single-day trawler operation, Photochemical ozone creation potential was maximum for diesel (86.2%) followed by vessel (7.8%), trawl nets (5.7%), lubricants (0.3%) and ice (0.1%).

Multi-day trawlers

Among the materials used for 13.71 m medium wooden multi-day trawler operation, POCP was maximum for diesel (86.9%) followed by vessel

(7.3%), trawl nets (5.4%) and lubricants (0.2%). In the case of 15.3 m medium wooden multi-day trawler operation, POCP was maximum for diesel (83.9%) followed by trawl nets (9.9%), vessel (5.8%), lubricants (0.2%) and ice (0.1%). In 18.9 m large wooden multi-day trawler operation, POCP was maximum for diesel (85.4%) followed by trawl nets (9.3%), vessel (5%), lubricants (0.2%) and ice (0.1%). In the case of 19.81 m large wooden multi-day trawler operation, POCP was maximum for diesel (88.4%) followed by trawl nets (5.6%), vessel (4.1%), lubricants (0.2%) and ice (0.1%). In 21.33 m large wooden multi-day trawler operation, POCP was maximum for diesel (88.2%) followed by trawl nets (7.3%), vessel (4.1%), lubricants (0.2%) and ice (0.1%).

Among the materials used for 13.71 m medium steel multi-day trawler operation, POCP was maximum for diesel (83.0%) followed by vessel (11.5%), trawl nets (5.2%) and lubricants (0.2%). In the case of 15.3 m medium steel multi-day trawler operation, POCP was maximum for diesel (80.7%) followed by trawl nets (9.6%), vessel (9.4%), lubricants (0.2%) and ice (0.1%). In 18.9 m large steel multi-day trawler operation, POCP was maximum for diesel (82.5%) followed by trawl nets (8.9%), vessel (8.3%), lubricants (0.2%) and ice (0.1%). In the case of 19.81 m large steel multi-day trawler operation, POCP was maximum for diesel (85.9%) followed by trawl nets (7.0%), vessel (6.8%), lubricants (0.2%) and ice (0.1%). In 21.33 m large steel multi-day trawler operation, POCP was maximum for diesel (84.9%) followed by trawl nets (8.6%), vessel (6.3%), lubricants (0.2%) and ice (0.1%). In the case of 22.86 m large steel multi-day trawler operation, POCP was maximum for diesel (85.4%) followed by trawl nets (8.5%), vessel (5.8%), lubricants (0.2%) and ice (0.1%). In 24.38 m very large steel multi-

day trawler operation, POCP was maximum for diesel (88.0%) followed by trawl nets (7.0%), vessel (4.7%), lubricants (0.1%) and ice (0.1%). In the case of 25.9 m very large steel multi-day trawler operation, POCP was maximum for diesel (88.6%) followed by trawl nets (7.0%), vessel (4.2%), lubricants (0.1%) and ice (0.1%). In 27.43 m very large steel multi-day trawler operation, POCP was maximum for diesel (88.6%) followed by trawl nets (7.2%), vessel (4.0%), lubricants (0.1%) and ice (0.1%).

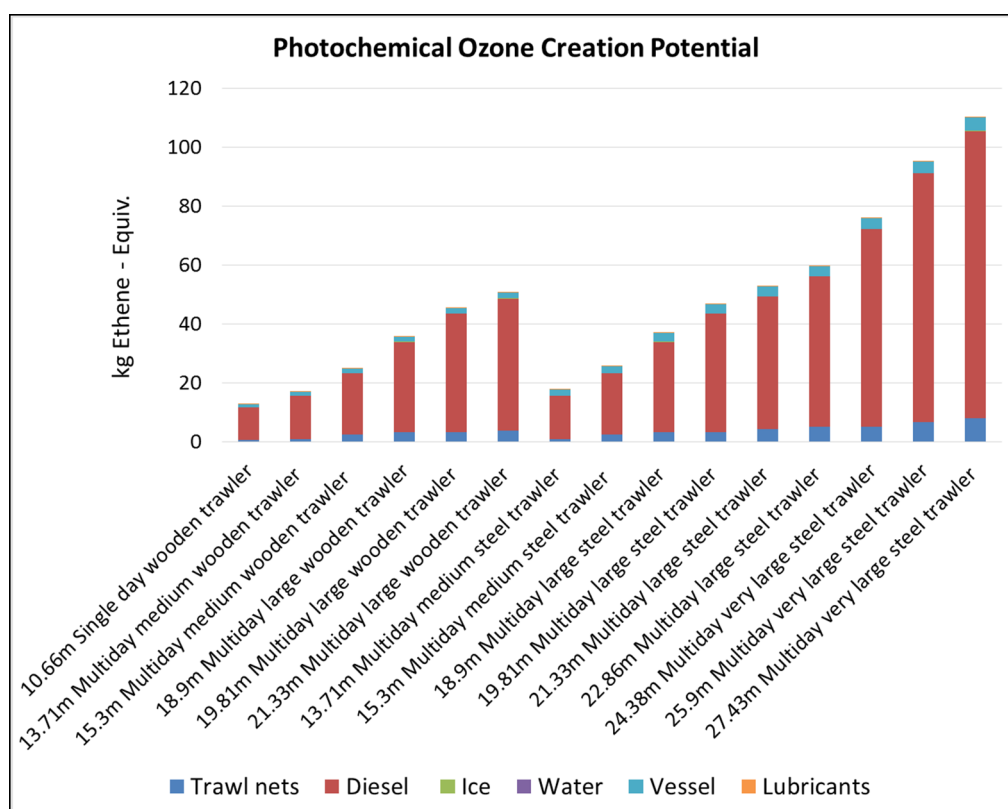

Fig. 6.9 Photochemical ozone creation potential for trawler operations, for different size categories

A comparison of POCP from single-day and multi-day trawler sectors in Kerala are given in Table 6.11.

Table 6.11: Photochemical ozone creation potential in single-day and multi-day trawler sectors in Kerala

Category	kg Ethene Equiv.
<i>Single-day trawlers</i>	
Wooden trawlers	4.47E+02
Trawl nets	3.25E+02
Diesel	4.94E+03
Lubricants	1.53E+01
Ice	3.23E+00
Water	1.89E+00
Sub-total	5.73E+03
<i>Multi-day trawlers</i>	
Steel trawlers	4.38E+03
Wooden trawlers	5.49E+02
Trawl nets	5.82E+03
Diesel	6.37E+04
Lubricants	1.21E+02
Ice	9.53E+01
Water	1.32E+01
Sub-total	7.47E+04
Total	8.04E+04

6.4.3 Estimates of impact category values per tonne of marine fish landed

Estimates of impact category values per tonne of marine fish landed during single-day and multi-day trawling operations are given in Table 6.12.

Table 6.12: Estimates of impact category values per tonne of marine fish landed during trawling operations in Kerala

Impact categories	Single-day trawl sector	Multi-day trawl sector	Both single-day and multi-day trawl sectors
GWP, kg CO ₂ Equiv.	985	1764	1674
ADP-fossil, MJ	1.26E+04	2.18E+04	2.07E+04
AP, kg SO ₂ Equiv.	3.16E+00	5.47E+00	5.21E+00
EP, kg Phosphate Equiv.	1.53E-01	2.67E-01	2.54E-01
MAETP, kg DCB Equiv.	5.22E+04	1.01E+05	9.52E+04
ODP, kg R11 Equiv.	5.60E-09	6.52E-09	6.42E-09
POCP, kg Ethene Equiv.	0.23	0.39	0.37

6.5 Discussion

The environmental burdens associated with the marine fish landings in trawl sector of Kerala are mainly linked with the usage of diesel particularly in operations. The strong dominance of energy use in trawling fisheries is the main reason for this situation, which is in agreement with previous studies (Boopendranath, 2000, 2008, 2012; Ziegler & Valentinsson, 2008; Ziegler *et al.*, 2009; Vázquez-Rowe *et al.*, 2010b; Vázquez-Rowe *et al.*, 2012a, Vivekanandan *et al.*, 2013). Most of the LCA and other environmental performance system studies have shown a clear dominance of vessel operations when it comes to impact assessment, particularly those associated with fuel consumption (Ziegler *et al.*, 2003; Thrane, 2004a,b; Hospido & Tyedmers, 2005; Ziegler & Valentinsson, 2008; Vázquez-Rowe *et al.*, 2010b).

Diesel represented the main source of GWP in single-day operations (97.4%) and multi-day trawling operations (92.6 - 97.5%) (Fig. 6.3). Studies by Vázquez-Rowe *et al.* (2014) and others (Edwin & Hridayanathan, 1997; Boopendranath, 2000, 2008, 2012; Ziegler *et al.*, 2003; Thrane, 2004a,b; Hospido & Tyedmers, 2005; Ziegler and Valentinsson, 2008; Ziegler *et al.*, 2009;

Vázquez-Rowe *et al.*, 2010b; Vázquez-Rowe *et al.*, 2012a, Vivekanandan *et al.*, 2013, Ghosh *et al.*, 2014) have shown that use of diesel in operations is the main source of GHG emissions.

The GWP was incrementally higher for multi-day trawler operation corresponding to its increase in size due to the inorganic emissions to air especially CO₂ emissions mostly derived from diesel. The remaining inputs showed less contributions to GWP. In the case of 27.43 m L_{OA} steel multi-day trawler operation, GWP was higher due to the inorganic emissions to air especially CO₂ (97.4%). 93.1% CO₂ emissions were from diesel. Global warming potential in single-day and multi-day trawler sectors in Kerala was 2.46E+07 and 3.38E+08 kg CO₂ Equiv., respectively. GWP estimated for the whole mechanised trawl fishing operations in Kerala was 3.62E+08 kg CO₂ Equiv. (Table 6.5). Global warming potential from single-day trawling operations was of 0.985 tonnes of CO₂ per tonne of marine fish landed and those from multi-day trawling operations was 1.764 tonnes of CO₂ per tonne of marine fish landed. Total GWP from both single-day and multi-day trawler sectors was of 1.674 tonnes of CO₂ per tonne of marine fish landed. Studies by Boopendranath (2000), Tyedmers *et al.* (2005) and Vivekanandan *et al.* (2013) also showed similar results with respect to carbon emission per tonne of marine fish landed. Multi-day trawlers emerged as the main sector contributing to the global warming potential, clearly ahead of single-day trawlers. Studies by Vázquez-Rowe *et al.* (2010b) on horse mackerel captured by bottom trawlers in Galicia (NW Spain) shows GWP of 2.3 tonnes of CO₂ per tonne of fish landed.

ADP-fossil was maximum from diesel (94.5%) in single-day operations and multi-day trawling operations (89.6 – 94.8%) (Fig. 6.4). The ADP-fossil was incrementally higher for single-day trawler operation and multi-day trawler operation corresponding to its increase in size due to the non

renewable energy resources especially crude oil (resource) mostly derived from diesel. In the case of 27.43 m L_{OA} steel multi-day trawler operation, ADP-fossil was higher due to the non renewable energy resources especially crude oil (resource) 88.5%. 86.1% crude oil (resource) are from diesel. Abiotic depletion potential (fossil) in single-day and multi-day trawler sectors in Kerala was $3.15E+08$ and $4.17E+09$ MJ respectively. ADP-fossil estimated for the whole mechanised trawl fishing operations in Kerala was $4.49E+09$ MJ (Table 6.6). ADP-fossil from single-day trawling operations was of $1.26E+04$ MJ per tonne of marine fish landed and those from multi-day trawling operations was $2.18E+04$ MJ per tonne of marine fish landed. Total ADP-fossil from both single-day and multi-day trawler sectors was $2.07E+04$ MJ per tonne of marine fish landed. Studies on sardines captured by mechanised ring seiners in Kerala has shown ADP-fossil as $4.97E+03$ MJ per tonne of fish landed (Das, pers. comm.).

AP was maximum from diesel (90.8%) in single-day operations and multi-day trawling operations (83.5 – 91.3%) (Fig. 6.5). The AP was incrementally higher for single-day trawler operation and multi-day trawler operation corresponding to its increase in size due to the inorganic emissions to air especially Sulphur dioxide and Nitrogen oxides mostly derived from diesel. In the case of 27.43 m L_{OA} steel multi-day trawler operation, AP was higher due to the inorganic emissions to air (99.9%) especially Sulphur dioxide (82.6%) and Nitrogen oxides (16.7%). Within inorganic emissions to air, 75.3% Sulphur dioxide and 14.8% Nitrogen oxides are from diesel. Acidification potential in single-day and multi-day trawler sectors in Kerala was $7.89E+04$ and $1.05E+06$ kg SO_2 Equiv. respectively. AP estimated for the whole mechanised trawl fishing operations in Kerala was $1.13E+06$ kg SO_2 Equiv. (Table 6.7). AP from single-day trawling operations was of $3.16E+00$

kg SO₂ Equiv. per tonne of marine fish landed and those from multi-day trawling operations was 5.47E+00 kg SO₂ Equiv. per tonne of marine fish landed. Total AP from both single-day and multi-day trawler sectors was 5.21E+00 kg SO₂ Equiv. per tonne of marine fish landed. Studies on sardines captured by mechanised ring seiners in Kerala has shown AP as 1.24E+00 kg SO₂ Equiv. per tonne of fish landed (Das, pers. comm.).

EP was maximum from diesel (88.1%) in single-day operations and multi-day trawling operations (80.4 – 88.6%) (Fig. 6.6). The EP was incrementally higher for single-day trawler operation and multi-day trawler operation corresponding to its increase in size due to the inorganic emissions to air especially Nitrogen oxides mostly derived from diesel. In the case of 27.43 m L_{OA} steel multi-day trawler operation, EP was higher due to the inorganic emissions to air (93.9%) especially Nitrogen oxides (89.7%). 79.5% Nitrogen oxides emissions are from diesel. Eutrophication Potential in single-day and multi-day trawler sectors in Kerala was 3.83E+03 and 5.10E+04 kg Phosphate Equiv. respectively. EP estimated for the whole mechanised trawl fishing operations in Kerala was 5.49E+04 kg Phosphate Equiv. (Table 6.8). Eutrophication potential from single-day trawling operations was of 1.53E-01 kg Phosphate Equiv. per tonne of marine fish landed and those from multi-day trawling operations was 2.67E-01 kg Phosphate Equiv. per tonne of marine fish landed. Total EP from both single-day and multi-day trawler sectors was of 2.54E-01 kg Phosphate Equiv. per tonne of marine fish landed. Studies on sardines captured by mechanised ring seiners in Kerala has shown EP as 5.97E-02 kg Phosphate Equiv. per tonne of fish landed (Das, pers. comm.).

MAETP was maximum from trawl nets (43.9%), followed by diesel (33.5%) and vessel (22.1%) in single-day operations and multi-day trawling operations (trawl nets (36.9 - 60.5%) followed by diesel (22.6 - 34.4%) and

vessel (13.0 - 33.7%) (Fig. 6.7). The MAETP was incrementally higher for single-day trawler operation and multi-day trawler operation corresponding to its increase in size due to the inorganic emissions to air especially Hydrogen fluoride. In the case of 27.43 m L_{OA} steel multi-day trawler operation, MAETP was higher due to the inorganic emissions to air (71.8%) especially Hydrogen fluoride (70.5%). 50.5% Hydrogen fluoride emissions are from trawl nets and 12.5% Hydrogen fluoride emissions are from vessel. Marine Aquatic Ecotoxicity Potential in single-day and multi-day trawler sectors in Kerala was $1.30E+09$ and $1.93E+10$ kg DCB Equiv. respectively. MAETP estimated for the whole mechanised trawl fishing operations in Kerala was $2.06E+10$ kg DCB Equiv. (Table 6.9). Marine aquatic ecotoxicity potential from single-day trawling operations was of $5.22E+04$ kg DCB Equiv. per tonne of marine fish landed and those from multi-day trawling operations was $1.01E+05$ kg DCB Equiv. per tonne of marine fish landed. Total MAETP from both single-day and multi-day trawler sectors was of $9.52E+04$ kg DCB Equiv. per tonne of marine fish landed. Studies on sardines captured by mechanised ring seiners in Kerala has shown MAETP as $1.06E+04$ kg DCB Equiv. per tonne of fish landed (Das, pers. comm.).

ODP was maximum from vessel (68.7%) followed by diesel (15.6%) and trawl nets (13.8%) in single-day operations and multi-day trawling operations (vessel (7.8 - 78.2%), followed by trawl nets (9.6 - 55.6%) and diesel (8.5 - 37.9%) (Fig. 6.8). The ODP was incrementally higher for single-day trawler operation corresponding to its increase in size due to the halogenated organic emissions into the air especially R114 (dichlorotetrafluoroethane) and R11 (trichlorofluoromethane). In the case of 21.33 m L_{OA} large wooden multi-day trawler operation, ODP was highest from due to the halogenated organic emissions into the air especially R114 (dichlorotetrafluoroethane) (63.9%) and

R11 (trichlorofluoromethane) (26.4%). 40.1% R114 (dichlorotetrafluoroethane) and 26.4% R11 (trichlorofluoromethane) emissions are from vessels. In the case of 27.43 m L_{OA} steel multi-day trawler operation, ODP was mainly due to the the halogenated organic emissions into the air especially R114 (dichlorotetrafluoroethane) (99.1%). 55.4% R114 (dichlorotetrafluoroethane) emissions are from trawl nets and 32.2% R114 (dichlorotetrafluoroethane) emissions are from diesel. Ozone depletion potential in single-day and multi-day trawler sectors in Kerala was $1.40E-04$ and $1.25E-03$ kg R11 Equiv. respectively. ODP estimated for the whole mechanised trawl fishing operations in Kerala was $1.39E-03$ kg R11 Equiv. (Table 6.10). Ozone Depletion Potential from single-day trawling operations was of $5.60E-09$ kg R11 Equiv. per tonne of marine fish landed and those from multi-day trawling operations was $6.52E-09$ kg R11 Equiv. per tonne of marine fish landed. Total ODP from both single-day and multi-day trawler sectors was of $6.42E-09$ kg R11 Equiv. per tonne of marine fish landed. In most of the international studies (Vázquez-Rowe *et al.*, 2010b; Vázquez-Rowe *et al.*, 2012a) ODP was higher mainly associated with the cooling agent (R22) emission due to the leakage in the storage freezers onboard fishing vessel. In Kerala, ODP related with trawl fishing was low, as there are no storage freezers onboard mechanised commercial trawlers. Studies on sardines captured by mechanised ring seiners in Kerala has shown ODP as $3.20E-09$ kg R11 Equiv. per tonne of fish landed (Das, pers. comm.).

POCP was maximum from diesel (86.2%) followed by vessel (7.8%) and trawl nets (5.7%) in single-day operations and multi-day trawling operations (diesel (82.5 - 88.6%) followed by vessel (4.0 - 11.5%) and trawl nets (5.2 - 9.9%)) (Fig. 6.9). The POCP was incrementally higher for single-day trawler operation and multi-day trawler operation corresponding to its increase in size due to the inorganic emissions to air especially Sulphur

dioxide, Nitrogen oxides and organic emissions especially group NMVOC to air. In the case of 27.43 m L_{OA} steel multi-day trawler operation, POCP was higher due to the inorganic emissions to air (64.8%) especially Sulphur dioxide (46.8%), Nitrogen oxides (13.2%) and organic emissions (35.2%) especially group NMVOC to air (32.1%). 42.7% Sulphur dioxide and 11.7% Nitrogen oxides emissions are from diesel. 29.1% Group NMVOC to air are from diesel. Photochemical ozone creation potential in single-day and multi-day trawler sectors in Kerala was 5.73E+03 and 7.47E+04 kg Ethene Equiv. respectively. POCP estimated for the whole mechanised trawl fishing operations in Kerala was 8.04E+04 kg Ethene Equiv. (Table 6.11). Photochemical Ozone Creation Potential from single-day trawling operations was of 0.23 kg Ethene Equiv. per tonne of marine fish landed and those from multi-day trawling operations was 0.39 kg Ethene Equiv. per tonne of marine fish landed. Total POCP from both single-day and multi-day trawler sectors was of 0.37 kg Ethene Equiv. per tonne of marine fish landed. Studies by Vázquez-Rowe *et al.* (2010b) on horse mackerel captured by bottom trawlers in Galicia (NW Spain) reported POCP as 0.53 kg Ethene per tonne of fish landed.

6.6 Conclusion

This is the first Life Cycle Assessment performed on mechanised trawl fishing operations in India covering aspects such as GWP, ADP-fossil, AP, EP, MAETP, ODP and POCP. The increased fuel consumption rate for multi-day trawl fishing operations compared to single-day operations is reflected in the results obtained for the LCA impact categories such as GWP, ADP, AP, EP and POCP, mostly related to consumption of diesel.

Diesel used for trawling operations are highlighted as the main hot spot in respect of environmental burdens and, therefore, requires action for minimizing fuel consumption in construction of craft and gear sub-systems and particularly in operations. GWP, ADP, AP, EP, MAETP, ODP and POCP values estimated for the entire mechanised trawl fishing sector in Kerala were 3.62E+08 kg CO₂ Equiv., 4.49E+09 MJ, 1.13E+06 kg SO₂, 5.49E+04 kg Phosphate Equiv., 2.06E+10 kg DCB Equiv., 1.39E-03 kg R11 Equiv. and 8.04E+04 kg Ethene Equiv. respectively. Total GWP from both single-day and multi-day trawler sectors was of 1.674 tonnes of CO₂ per tonne of marine fish landed. Total ADP-fossil from both single-day and multi-day trawler sectors was 2.07E+04 MJ per tonne of marine fish landed. Total AP from both single-day and multi-day trawler sectors was 5.21E+00 kg SO₂ Equiv. per tonne of marine fish landed. Total EP from both single-day and multi-day trawler sectors was of 2.54E-01 kg Phosphate Equiv. per tonne of marine fish landed. Total MAETP from both single-day and multi-day trawler sectors was of 9.52E+04 kg DCB Equiv. per tonne of marine fish landed. Total ODP from both single-day and multi-day trawler sectors was of 6.42E-09 kg R11 Equiv. per tonne of marine fish landed. Total POCP from both single-day and multi-day trawler sectors was of 0.37 kg Ethene Equiv. per tonne of marine fish landed. LCA is a useful decision making tool for evaluating inputs and their relative contribution to impact categories causing environmental burdens in fish production systems and to identify hotspots and mitigation measures. Hot spots causing maximum environmental impacts in trawl fishing sector have been elaborated in the ensuing chapter.

.....❧.....

HOTSPOTS AND APPROACHES TO REDUCE ENVIRONMENTAL IMPACTS OF THE TRAWL FISHERIES

7.1 Introduction

India is reported to be the third largest greenhouse gas emitter in the world (BP Statistical Review, 2015). The global warming potential is among the most common impact categories assessed (Iribarren *et al.*, 2010a). Product processing stage appears to have relatively small impact potential in most of the studies (Thrane, 2004a&b). According to Eyjólfsdóttir *et al.* (2003), LCA can be used for indicating hot spots within production chain. The life cycle assessment of the Kerala trawl fishing sector has facilitated identification of hotspots requiring maximum attention in mitigation of environmental impacts of the sector.

The fact that fishing is the only food producing activity that relies mainly on the extraction of organisms from oceans (Christensen *et al.*, 2003), creates numerous issues, regarding the stability of the stocks of targeted species in the ecosystem, the effect of discards on the marine environment or the damage of the seabed due to trawling (Hall-Spencer *et al.*, 2002; Guyonnet *et al.*, 2008) and environmental burdens due to energy-intensive nature of trawling operations (Boopendranath, 2000, 2008; Tyedmers, 2001, Thrane, 2004b, Ziegler & Valentinsson, 2008; Ziegler *et al.*, 2009; Vivekanandan *et al.*, 2013 and Vázquez-Rowe *et al.*, 2014). Linked to these problems, the decline in marine fish stocks off Kerala waters has been an important matter of

concern for fisheries scientists and stakeholders in harvest and post-harvest sectors, in recent years. The decline of marine fish production of Kerala during the last three years is shown in Table 7.1. The decreasing trend in production will entail in escalation in energy use in maintaining fish production.

Table: 7.1. Marine fish production of Kerala during the last three years

Year	Fish production (lakh tonnes)	Rank among maritime states in India
2012	8.39	First
2013	6.71	Third
2014	5.76	Third

Source: CMFRI (2013a, 2014, 2015)

In this Chapter, an attempt is made to identify important hotspots in terms of life cycle inventories based on the present study and delineate approaches to reduce the GWP and related impacts.

7.2 Hotspots identified in trawler construction and maintenance

In the case of wooden trawlers, higher Global warming potential (GWP) is for aluminium, followed by steel. In the case of steel trawlers, higher GWP is for steel especially hull, followed by welding electrodes. Steel as a construction material has higher global warming potential than wood. However, scarcity of wood appropriate for vessel construction is a limiting factor. Upgrading of wooden boat building materials sourced from high yielding short life span wood species after preservative treatment, can be considered for construction, wherever appropriate, particularly for coastal operations.

In the case of steel trawlers, the Abiotic depletion potential - fossil (ADP-fossil) was higher due to the non-renewable energy resources especially hard coal (resource) and crude oil (resource). Hard coal (resource) were from steel used for construction (especially from hull) and crude oil (resource) were

from use of electrodes. In the case of steel trawlers, the Acidification potential (AP) was higher due to the inorganic emissions to air especially Sulphur dioxide and Nitrogen oxides which is mostly derived from steel especially hull. The Eutrophication potential (EP) was high in steel trawlers due to the inorganic emissions to air especially Nitrogen oxides mostly derived from steel especially hull. The Marine aquatic ecotoxicity potential (MAETP) was higher in steel trawlers due to the inorganic emissions to air especially Hydrogen fluoride which is mostly derived from steel and electricity.

Ozone depletion potential (ODP) was comparatively low in trawler construction and maintenance. In the case of wooden multi-day trawlers, Ozone depletion potential was due to the halogenated organic emissions into the air especially R114 (dichlorotetrafluoroethane) and R11 (trichlorofluoromethane) mostly derived from copper nails and aluminium sheet.

In the case of steel trawlers, Photochemical ozone creation potential (POCP) was mainly due to the inorganic emissions to air especially Carbon monoxide, Sulphur dioxide and Nitrogen oxides mostly derived from steel and organic emissions especially group Non-methane volatile organic compounds (NMVOC) to air which is mostly derived from wood.

7.3 Hotspots identified in trawl net construction and maintenance

In the case of trawl nets, higher GWP is for HDPE webbing, followed by iron sinkers, HDPE floats, PP ropes and lead sinkers. As far as impact category GWP is concerned, lead sinkers seem to be a better option than iron sinkers as they have better service life and resale value than iron sinkers. As GWP value is higher for HDPE webbing, approaches to reduce its usage in trawl construction such as trawl design improvement, use of large meshes,

knotless webbing and substitution with thinner and stronger materials with low drag (Wileman, 1984) have to be reviewed.

The ADP - fossil in trawls are mainly due to the consumption of non-renewable energy resources especially crude oil (resource), natural gas and hard coal (resource) mostly derived from HDPE webbing and iron sinkers. The AP in trawls are mainly due to the inorganic emissions to air especially Sulphur dioxide and Nitrogen oxides mostly derived from HDPE webbing, iron sinkers and HDPE floats. The EP in trawls are mainly due to the inorganic emissions to air especially Nitrogen oxides mostly derived from HDPE webbing, iron sinkers and HDPE floats. The MAETP in trawls are mainly due to the inorganic emissions to air especially Hydrogen fluoride, mostly derived from HDPE webbing, iron sinkers and HDPE floats. ODP in trawls were mostly due to the halogenated organic emissions into the air especially R114 (dichlorotetrafluoroethane) mostly derived from HDPE webbing and HDPE floats. POCP from trawls were due to the inorganic emissions to air especially Sulphur dioxide, Nitrogen oxides and organic emissions especially group NMVOC to air mostly derived from HDPE webbing followed by iron sinkers.

7.4 Hotspots identified in trawling operations

There is considerably higher environmental impacts for multiday trawl landings mainly due to the high energy consumption. The fuel consumption (diesel production and use) is the major factor contributing to GWP in both single day and multiday trawler operations and hence offers maximum scope for impact reduction, through operational fuel savings. This observation is in agreement with earlier studies by Edwardson (1976), Watanabe and Okubo (1989), Boopendranath (2000, 2008, 2012), Ziegler *et al.* (2003), Thrane (2004b), Hospido and Tyedmers (2005), Tyedmers *et al.* (2005), Schau *et al.*

(2009), Torres *et al.* (2010), Vázquez-Rowe *et al.* (2010b, 2011), Iribarren *et al.* (2011) and Vivekanandan *et al.* (2013). The GWP was incrementally higher for multi-day trawler operations corresponding to increase in size of trawlers, due to the inorganic emissions to air especially CO₂ emissions

The ADP-fossil was incrementally higher for single-day trawler operation and multi-day trawler operation corresponding to increase in size of trawlers, due to the non-renewable energy resources especially crude oil (resource) mostly derived from diesel. The AP for single-day trawler operation and multi-day trawler operation also showed increase corresponding to increase in size of trawlers, due to the inorganic emissions to air especially Sulphur dioxide and Nitrogen oxides mostly derived from diesel. Similarly, the EP also showed incrementally higher values for single-day trawler operation and multi-day trawler operation corresponding to increase in size of trawlers, due to the inorganic emissions to air especially Nitrogen oxides mostly derived from diesel.

The MAETP values increased for single-day trawler operation and multi-day trawler operation corresponding to increase in size of trawlers, due to the inorganic emissions to air especially Hydrogen fluoride mostly derived from HDPE webbing and use of iron sinkers in trawl nets; diesel; and steel and electricity for vessel construction and maintenance.

Vázquez-Rowe *et al.* (2012a) studied that ODP in fishing vessels which was mainly associated with the leakage of cooling agent (R22) from the storage freezers onboard. In Kerala, ODP related with trawl fishing was low, as there are no storage freezers onboard mechanised commercial trawlers. However, ODP was incrementally higher for single-day and multi-day trawler operations corresponding to increase in size of the trawlers, due to the halogenated organic emissions into the air especially R114 (dichlorotetrafluoroethane) and R11

(trichlorofluoromethane) emissions mostly derived from copper nails and aluminium sheets used for wooden vessel construction.

POCP values for single-day and multi-day trawler operations increased in accordance with increase in size of the trawlers, due to the inorganic emissions to air especially Sulphur dioxide, Nitrogen oxides and organic emissions especially group NMVOC to air mostly derived from diesel.

7.5 Fuel consumption in mechanised trawling operations

All mechanised trawlers use diesel for propulsion, gear handling and operations. It was estimated from the present study that, single-day trawling operations from Kerala consumes 7.6 million litres (6.31 million t) of fuel and the multi-day trawling operations from Kerala consumes 98.7 million litres (81.92 million t) of fuel annually. The total quantity of diesel burned by the mechanised trawl sector in Kerala fisheries accounted for 106.3 million litres (88.23 million t) of fuel during the period June 2012 to May 2013. The quantity of fuel consumed per kg of marine fish landed works out to be 0.25 kg for single-day trawlers, 0.43 kg for multi-day trawlers and 0.41 kg for both the sectors together. Studies by Boopendranath (2000; 2008; 2012) in India showed a fuel consumption rate of 0.41, 0.38 and 0.33 kg fuel kg fish⁻¹ from motorised mini-trawling, small-scale mechanised bottom trawling and large-scale mechanised aimed midwater trawling, respectively. Studies by Tyedmers (2001) in North Atlantic showed a fuel consumption rate of 0.44, 0.76 and 0.85 kg fuel kg fish⁻¹ for groundfish trawling, shrimp trawling and Norwegian lobster trawling, respectively. Tyedmers (2001), Eyjólfsdóttir *et al.* (2003), Ziegler *et al.* (2003), Thrane (2004b), Ellingsen and Aanonsen (2006) and Guttormsdóttir (2009) reported 0.67 kg fuel kg fish⁻¹ for cod harvested by trawling. Studies by Thrane (2004a&b) showed a fuel consumption rate of 0.4

and 0.84 kg fuel kg fish⁻¹ respectively, for cod and flatfish harvested by bottom trawling in Denmark. Studies by Ziegler and Hansson (2003) in Iceland and Schau *et al.* (2009) in Norway reported a fuel consumption rate of 0.65 and 0.28 kg fuel kg fish⁻¹ respectively for groundfish trawling. Thrane (2004b), Iribarren *et al.* (2010a) and Vázquez-Rowe *et al.* (2010b) reported a fuel consumption rate of 0.30 kg fuel kg fish⁻¹ for mackerel caught by trawling. Studies by Emanuelsson *et al.* (2008) showed a fuel consumption rate of 0.52 kg fuel kg fish⁻¹ for artisanal trawling of shrimps and prawns, in Senegal. Parker and Tyedmers (2015) have studied the current understanding and knowledge gaps in fuel consumption of global fishing fleets and reported that the median fuel use intensity of global fishery since 1990 as 639 litres per tonne and that fuel inputs to fisheries vary by several orders of magnitude, in different categories of fishing.

In the Indian context, annual fuel consumption by the mechanised and motorised fishing fleet has been reported to be 1220 million litres which formed about 1% of the total fossil fuel consumption in 2000 (Boopendranath, 2000). These release an estimated 3.17 million tonnes of CO₂ into the atmosphere at an average rate of 1.13 tonnes of CO₂ per tonne of marine fish landed. Vivekanandan *et al.* (2013) had estimated the diesel burning by the mechanised and motorised fishing vessels in India as 1378.8 million litres in 2010. These release about 3.13 million tonnes of CO₂ into the atmosphere at an average rate of 1.02 tonnes of CO₂ per tonne of live-weight of marine fish landed. The LCA studies indicate that about 0.362 million tonnes of CO₂ Equiv. was released into the atmosphere from sources such as construction and maintenance of trawlers and trawl fishing gears and trawling operations, in Kerala, at an average rate of 1.674 tonnes of CO₂ per tonne of marine fish landed by trawling.

For operations alone, the consumption of fuel by the trawler fleet in Kerala has been estimated in this study as 106.3 million litres which releases about 0.280 million tonnes of CO₂.

7.6 Approaches to reduce environmental impacts of the trawl fisheries

LCA is useful for evaluating environmental burdens of inputs and the relative contribution of impact categories in fish production systems and to identify hotspots and mitigation measures. The LCA performed on mechanised trawl fishing operations in Kerala covering impact categories such as GWP, ADP-fossil, AP, EP, MAETP, ODP and POCP has highlighted several hotspots where attention is required to minimise the environmental impacts. Hot spots causing maximum environmental impacts in trawl fishing sector have been elaborated in the Chapters 4-6.

The GWP, ADP-fossil, AP, EP, MAETP, and POCP was consistently higher in steel trawlers, and their values increased with increase in size of the trawlers and consumption of steel in construction. Hence there is scope for optimisation in hull design and material substitution wherever appropriate, aiming at reduction in steel consumption, in the construction of steel trawlers. It will also be advisable to optimise vessel size for coastal and distant water trawling operations. Though GWP values were consistently negative for wooden vessels and decreased with vessel size, availability of wood appropriate for vessel construction is becoming scarce and expensive. ODP, though low in value, was higher in wooden trawlers compared to steel hulled trawlers, due to the use of copper nails and aluminium sheathing in their construction. It will be appropriate to identify substitutes for copper and aluminium in the construction of wooden trawlers.

The values for GWP, ADP-fossil, AP, EP, MAETP, POCP and ODP for trawl construction mostly depended on the consumption of HDPE webbing, followed by use of iron sinkers and floats. As pointed out, approaches to reduce the consumption and use of HDPE webbing, iron sinkers and HDPE floats through design optimisation and material substitution wherever appropriate, seem to be necessary. Substituting lead sinkers, which have better service life, in place of iron sinkers may bring down contribution of sinkers in GWP of trawls.

Among the LCA impact categories, GWP, ADP, AP, EP and POCP are predominantly related to the consumption of diesel. Hence, diesel used for trawling operations can be highlighted as the main hot spot in respect of environmental burdens and, therefore, focussed action is required for minimizing fuel consumption in construction of craft and gear sub-systems and particularly in operations. Total GWP from trawler sector was of 1.674 tonnes of CO₂ Equiv. per tonne of marine fish landed. Total ADP-fossil, AP, EP, MAETP, ODP and POCP have been estimated to be 2.07E+04 MJ, 5.21E+00 kg SO₂ Equiv., 2.54E-01 kg Phosphate Equiv., 9.52E+04 kg DCB Equiv., 6.42E-09 kg R11 Equiv. and 0.37 kg Ethene Equiv. per tonne of marine fish landed.

Significant improvement in operational savings of fuel can be achieved by optimised vessel hull design. The introduction of new vessels into the fisheries with improved hull shapes can provide energy efficiency improvements up to 20% (Schau *et al.*, 2009) and need to be considered as a long term strategy. As trawlers use high powered engines, skippers tend to move at high speed even for going to and from fishing grounds which consumes more fuel. Gulbrandsen (2012) estimated that a reduction of 10-20% rpm from its full

speed will save 20-40% fuel. Economic vessel speed is a well-known practical measure among the fuel saving practices. Appropriately smaller engines have multiple benefits of lower investment cost, lesser maintenance and huge reduction in the fuel consumption. Preventive maintenance including regular cleaning or replacement of the required parts of engine are very important practical steps in conserving fuel and controlling pollution.

Approaches for energy conservation and minimization of GHG emissions from fishing operations have been reviewed by Gulbrandsen (1986), Wileman (1984), Aegisson and Endal (1993), Edwin and Hridayanathan (1997), Boopendranath (1996; 2009), Wilson (1999), Berg (2007), Sterling and Goldsworthy (2007), Sterling and Kim (2012), Espadafor *et al.* (2009), Feng (2010), Rihan *et al.* (2010), Walsh (2010), TEFLES (2012) and Boopendranath and Hameed (2013) and include the appropriate adoption of the following: (i) low energy fishing techniques; (ii) low drag trawls; (iii) pair trawling; (iv) economic vessel speed; (v) hull design; (vi) effective anti-fouling measures; (vii) appropriate choice of engines; (viii) right sizing of engines; (ix) preventive maintenance of engines; (x) appropriate propeller size and propeller nozzle; (xi) alternate energy including wind energy and solar energy; (xii) use of advanced technology such as acoustic fish detection devices (echosounder, sonar and gear monitoring system), Global Positioning System (GPS), Potential Fishing Zone (PFZ) information based on remote sensing, and Geographical Information System (GIS); (xiii) Fish Aggregating Devices (FADs); (xiv) effective fleet management and voyage optimization; and (xv) removal of excess fishing capacity. Recent studies in the fishing sector suggest that fish stocks that are managed in a sustainable way are capable of maintaining their GHG emissions at lower levels (Hornborg *et al.*, 2012).

7.7 Conclusion

LCA arose as a potential support tool for decision making within the fishing sector, conducive to the identification of opportunities for climate change mitigation. In trawl fisheries of Kerala, LCA impact categories such as such as GWP, ADP-fossil, AP, EP and POCP are predominantly related to the consumption of diesel in vessel operation followed by vessel and gear construction and maintenance. MAETP values are higher for trawls due to consumption of HDPE webbing and floats compared to consumption of diesel in operations and vessel construction. ODP values, which are usually due to the leakage of refrigerants, were negligible in the absence of freezer facilities onboard trawlers in Kerala and were attributed to the usage of copper nails and aluminium sheathing in construction of wooden trawlers. Selection and deployment of energy efficient mix of harvesting technologies appropriate for target resources is one of the main options suggested for fuel conservation. Adoption of energy and material conservation and optimisation technologies and practices in vessel and gear construction and trawling operations will pave way for reduction of environmental impacts from trawl sector.

.....*DS*.....

SUMMARY AND RECOMMENDATIONS

Most of the environmental problems that confront mankind today are connected to the use of energy in one way or another. Modern fishing is one of the most energy intensive methods of food production. Mechanised fishing operations are dependent on fossil fuels which are non-renewable and releases high levels of carbon dioxide to the atmosphere contributing to greenhouse effect. Information on Life Cycle Assessment wherein impact categories like Global warming potential (GWP), Abiotic depletion potential-fossil (ADP-fossil), Acidification potential (AP), Eutrophication potential (EP), Marine aquatic eco-toxicity potential (MAETP), Ozone depletion potential (ODP) and Photochemical ozone creation potential (POCP) are entirely lacking in respect of Indian trawl fisheries. Such an analysis provides an unbiased decision making support for maximising the yield per unit from trawl fishery resource systems, by rational deployment of trawl harvesting systems. In the present study, results of investigations conducted on the structural changes, life cycle assessment and carbon footprint studies and hotspot identified in trawl fish harvesting systems are presented. The content of the thesis is organised into 8 chapters.

The first chapter gives the background of the topic of study, its relevance and significance; reviews the existing literature in the subject area and sets out objectives of the study. Objectives of the present study were to (i) investigate structural changes in the mechanised trawl fishing sector in Kerala in recent years; (ii) study Life Cycle Assessment and Carbon Footprint of trawlers; (iii) study Life Cycle Assessment and Carbon Footprint of trawl gear

systems; (iv) study Life Cycle Assessment and Carbon Footprint of trawl landings; and (v) identify hotspots and approaches to reduce environmental impact of the trawl fisheries.

In the second chapter, materials and methods adopted for the present study including the study area are covered. Methods adopted for finding the structural changes in trawlers in recent years and procedures for determining Life Cycle Assessment and Carbon Footprint are described in detail. Approaches for data collection regarding vessel construction, gear fabrication and inputs for operational aspects are also covered.

The third chapter presents a comparison of the structural changes in trawl fishing sector in Kerala, in terms of L_{OA} and installed engine horsepower over the last decade. The results have demonstrated large scale changes in the structure of the mechanised fishing fleet of Kerala, both in terms of size and installed engine horsepower among trawlers. The study indicated an exponential increase in engine horsepower among trawlers above 18 m in L_{OA} , in recent years. With increasing fishing pressure in coastal waters and diminishing returns, the area of operation of mechanised fleet has further extended to deeper waters and vessels with larger size, power and capacities equipped for multi-day fishing have become popular. The study also suggests the need to account for the increase in the fishing capacity of the vessels while planning for fishing fleet restrictions.

The fourth chapter covers life cycle assessment and carbon footprint studies of small (<12 m L_{OA}), medium (12-16 m L_{OA}), large (16-24 m L_{OA}) and very large (>24 m L_{OA}) trawlers constructed of either wood or steel. This chapter also gives a detailed description of each category of vessels, along with the design and the material inputs for construction and maintenance. The

results denoted that Global warming potential was higher in very large steel multi-day trawlers due to the inorganic emissions to air especially CO₂. The Abiotic depletion fossil was higher in steel trawlers especially very large types due to the non-renewable energy resources namely hard coal (resource) and crude oil (resource). The Acidification potential was higher in steel trawlers due to the inorganic emissions to air especially Sulphur dioxide and Nitrogen oxides which is mostly derived from steel. The Eutrophication potential was high in steel trawlers due to the inorganic emissions to air especially Nitrogen oxides mostly derived from steel. The Marine aquatic ecotoxicity potential was higher in steel trawlers due to the inorganic emissions to air especially Hydrogen fluoride which is mostly derived from steel and electricity consumption. Ozone depletion potential was higher in wooden trawlers due to the halogenated organic emissions into the air especially R114 (dichlorotetrafluoroethane) and R11 (trichlorofluoromethane) which is mostly derived from copper nails and aluminium sheet used in wooden boat construction. Photochemical ozone creation potential was higher in steel trawlers due to the inorganic emissions to air especially Carbon monoxide, Sulphur dioxide and Nitrogen oxides, mostly derived from steel.

The fifth chapter deals with life cycle assessment and carbon footprint studies of different types of trawl nets *viz.*, fish trawls, shrimp trawls and cephalopod trawls. This chapter gives a detailed description of the design of each type of trawl nets and the material inputs for their fabrication. The Global warming potential in trawls are mainly due to the inorganic emissions to air especially CO₂ mostly derived from HDPE webbing, iron sinkers and HDPE floats, and ranged from 214 to 1357 kg CO₂ Equiv. The Abiotic depletion (fossil) in trawls are mainly due to consumption of non-renewable energy resources especially crude oil (resource), natural gas and hard coal (resource)

mostly derived from HDPE webbing and iron sinkers, and ranged from 3148 to 28992 MJ. The Acidification potential in trawls are mainly due to the inorganic emissions to air especially Sulphur dioxide and Nitrogen oxides mostly derived from HDPE webbing, iron sinkers and HDPE floats, and ranged from 1.61 to 9.34 kg SO₂ Equiv. The Eutrophication potential in trawls are mainly due to the inorganic emissions to air especially Nitrogen oxides mostly derived from HDPE webbing, iron sinkers and HDPE floats, and ranged from 0.088 to 0.553 kg Phosphate Equiv. The Marine aquatic ecotoxicity potential in trawls are mainly due to the inorganic emissions to air especially Hydrogen fluoride, mostly derived from HDPE webbing, iron sinkers and HDPE float, and ranged from 207992 to 1258878 kg DCB Equiv. Ozone depletion potential in trawls were mainly due to the halogenated organic emissions into the air especially R114 (dichlorotetrafluoroethane) mostly derived from HDPE webbing and HDPE floats, and ranged from 6.57E-09 to 6.90E-08 kg R11Equiv. Photochemical ozone creation potential from trawls were due to the inorganic emissions to air especially Sulphur dioxide, Nitrogen oxides and organic emissions especially group Non-methane volatile organic compounds (NMVOC) to air mostly derived from HDPE webbing followed by iron sinkers, and ranged from 0.112 to 0.725 kg Ethene Equiv.

Chapter 6 presents life cycle assessment and carbon footprint studies of trawling operation from 15 types of trawlers coming under different L_{OA} with wood and steel as construction material using different combinations of nets, *viz.*, fish trawl, shrimp trawl and cephalopod trawl, and undertaking either single-day or multi-day operations. The values of impact categories per tonne of marine fish landed by trawl fishing sector in Kerala are also estimated and presented. The increased fuel consumption rate for multi-day trawl fishing

operations compared to single-day operations is reflected in the results obtained for the LCA impact categories such as GWP, ADP, AP, EP and POCP, mostly related to consumption of diesel. Diesel used for trawling operations are highlighted as the main hotspot in respect of environmental burdens and, therefore, requires action for minimizing fuel consumption in construction of craft and gear sub-systems and particularly in operations. GWP from single-day trawling operations was of 0.985 tonnes of CO₂ per tonne of marine fish landed and those from multi-day trawling operations was 1.764 tonnes of CO₂ per tonne of marine fish landed. Total GWP from both single-day and multi-day trawler sectors was of 1.674 tonnes of CO₂ per tonne of marine fish landed.

The penultimate chapter attempts to identify important hotspots in terms of life cycle inventories based on the present study and delineate approaches to reduce the GWP and other impacts. In trawl fisheries of Kerala, LCA impact categories such as GWP, ADP-fossil, AP, EP and POCP are predominantly related to the consumption of diesel in vessel operation followed by vessel and gear construction and maintenance. MAETP values are higher for trawls due to consumption of HDPE webbing and floats compared to consumption of diesel in operations and vessel construction. ODP values, which are usually due to the leakage of refrigerants, were negligible in the absence of freezer facilities onboard trawlers in Kerala and were attributed to the usage of copper nails and aluminium sheathing in construction of wooden trawlers. Selection and deployment of energy efficient mix of harvesting technologies appropriate for target resources is one of the main options suggested for fuel conservation. Adoption of energy and material conservation and optimisation technologies and practices in vessel and gear construction

and trawling operations will pave way for reduction of environmental impacts from trawl sector.

The final chapter comprises of summary and recommendations emanating from the study. This is the first Life Cycle Assessment study performed on trawl fishing fleet in India wherein impact categories like Global warming potential, Abiotic depletion potential (fossil), Acidification potential, Eutrophication potential, Marine aquatic eco-toxicity potential, Ozone layer depletion potential and Photochemical ozone creation potential are considered. According to the current levels of consumption, the fossil fuels may not last long, unless urgent conservation measures are taken. By taking the right action now, the fishing industry can lower its fuel costs, reduce its contribution to greenhouse gas emissions, and minimise the environmental impacts. Any measure for decreasing the use of energy in fishery, will have an impact on the overall environmental performance of the fish caught.

Recommendations

1. Adoption of Life Cycle Assessment (LCA) method in fisheries will help to gain precise information about the environmental impacts of the fish caught as well as the products developed from it.
2. LCA facilitates adoption of a mix of fish harvesting systems to be employed for optimising fuel use in the capture fish production in a region and delineate approaches for energy conservation.
3. As GWP, ADP-fossil, AP, EP, MAETP, and POCP values were consistently higher in steel trawlers, there is scope for optimisation in hull design and material substitution wherever appropriate, for reduction in steel consumption. It is necessary to optimise and standardise size and capacities of trawlers including engine

horsepower, for coastal and distant water trawling operations and the same implemented through fishery regulations.

4. Though GWP values were consistently negative for wooden vessels and decreased with vessel size, availability of wood appropriate for vessel construction is a limiting factor. Upgrading of boat building materials sourced from high yielding short life span wood species, can be considered for coastal operations.
5. As ODP value, though of low magnitude, was higher in wooden trawlers compared to steel hulled trawlers, due to the use of copper nails and aluminium sheathing in their construction, it will be appropriate to identify suitable substitutes for these materials.
6. In trawl nets, as HDPE webbing is the most common material contributing to GHG emission, approaches to reduce its use through design optimisation and material substitution, wherever appropriate, seem to be necessary. Substituting lead sinkers, which have better service life, in place of iron sinkers may bring down contribution of sinkers in GWP of trawls.
7. In the LCA analysis of trawl caught fishes, the impact categories such as GWP, ADP, AP, EP and POCP are predominantly related to the consumption of diesel in vessel operation followed by vessel and gear construction and maintenance, and, hence, it is highlighted as the main hotspot in respect of environmental burdens which need focussed action in mitigation approaches. Significant improvement in operational fuel savings can be achieved by adopting energy saving technologies and practices, replacement with eco-friendly source of energy and sustainable management of the fisheries.

8. As the information derived from LCA studies enables consumers and seafood processing industries to opt for fishes harvested by methods causing less environmental burdens, such studies need to be widely adopted in order to safeguard the health of ecosystems and facilitate production of eco-friendly seafood products and market driven conservation of resources through eco-labelling.

.....❧.....

REFERENCES

- Abernethy, K.E., Trebilcock, P., Kebede, B., Allison, E.H. and Dulvy, N.K. (2010) Fuelling the decline in UK fishing communities? ICES Journal of Marine Science 67: 1076–1085.
- Aegisson, G. and Endal, A. (1993) Energy Conservation Programme in Indian Fisheries - Report from the Preparatory Phase, Report No. 402009.00.01.93, MARINTEK, Norwegian Marine Technology Research Institute, Trondheim, Norway: 45 p.
- Ágústsson, A., Ragnarsson, E. and Laxdal, H. (1978) Fuel consumption of Icelandic fishing vessels. *Ægir- tíðmarit um sja'varu' tveg.* 71(11):462–86
- Allen, K. R. (1981) Energy Inputs and Outputs in an Australian Coastal Whaling Operation. In: *Mammals in the Sea, Volume 3*, FAO. 375-377.
- Alpanda, S. and Peralta-Alva, A. (2010) Oil crisis, energy-saving technological change and the stock market crash of 1973-74. *Transportation Research*, 11: 161-165.
- Alverson, D.L., Freeberg, M.H., Murawski, S.A. and Pope J.G. (1994) A global assessment of fisheries bycatch and discards. FAO FISH. Technical Paper no. 339. FAO, Rome, Italy.
- Anon (1984) Meeting the challenges of the EEZ - some thoughts on fishing craft technology in India, *Bay of Bengal News* 13:10-11, 24.
- Anon (1989a) Proceedings of the International Fisheries Energy Optimisation Working Group Meeting, 28-30 August, 1989, University of British Columbia, Vancouver, B.C., Canada.
- Anon (1989b) Proceedings of the World Symposium on Fishing Gear and Fishing Vessel Design 1988, Marine Institute (The Newfoundland and

- Labrador Institute of Fisheries and Marine Technology), St. John's, Newfoundland, Canada: 610 p
- Anon (1993) Proceedings of the National Workshop on Low Energy Fishing, 8-9 August, 1991, Cochin, Fishery Technology, Special Issue, Society of Fisheries Technologists, Cochin, India: 294 p.
- Anon (2013) <http://co2now.org/>. Accessed on 13 June 2013.
- Avadi, A. and Freon, P. (2013) Life cycle assessment of fisheries: A review for fisheries scientists and managers, *Fisheries Research* 143: 21-38.
- BACAS (2006) Hydrogen as an energy carrier. Brussel: Royal Belgian Academy Council
- Baiju, M.V., Boopendranath, M.R. and Edwin, L. (2012) Need for regulating horsepower race in small-scale mechanised fishing vessels. *Fisheries Policy Update* 8, Central Institute of Fisheries Technology, Cochin, 6 p.
- Bak, F. (1994) Brancheenergianalyse og standardløsninger for fiskeriet. Århus: DTI Energi, Motorteknik.
- Balash, C. and Sterling, D. (2012) Prawn Trawl Drag due to Material Properties – An investigation of the potential for drag reduction, Second International Symposium on Fishing Vessel Energy Efficiency E-Fishing, Vigo, Spain, May 2012, 9 p.
- Bardach, J.E. (1982) Oil, fish and the sun and the wind, p. 1-14, In: May, R.C., Smith, I.R. and Thomson, D.B. (Eds.) (1982) *Appropriate Technology for Alternative Energy Sources in Fisheries*, Proceedings of the ADB-ICLARM Workshop on Appropriate Technology for Alternative Energy Sources in Fisheries, Manila, Philippines, 21-24 February, 1981, ICLARM Conf. Proc. 8.

- Ben-Yami, M. (1989) Trends in boats motorization in the artisanal fisheries: the cases of Nigeria, Equador and Kenya, Paper 1.3, In: Proceedings of International Fisheries Energy Optimisation Working Group Meeting, 28-30 August, 1989, University of British Columbia, Vancouver, B.C., Canada.
- Ben-Yami, M. (1993) Scope for low energy fishing in the present world fisheries context, p. 121-125, In: Proceedings of the National Workshop on Low Energy Fishing, Fishery Technology, Special Issue, Society of Fisheries Technologists, Cochin, India.
- Berg, A. (2007) Trekkraftberegninger “Fremtidens Tråler” MT53 F07-096/530397.00.01, SINTEF Report.
- Bhathal, B. (2005) Historical Reconstruction of Indian Fisheries Catches, 1950-2000, as Basis for Testing the ‘Marine Trophic Index’, The Fisheries Centre, Fisheries Research Centre Reports 13(5), University of British Columbia, Vancouver, B.C., 122 p.
- Bhathal, B. and Pauly, D. (2008) Fishing down marine food webs and spatial expansion of coastal fisheries in India, 1950-2000. Fisheries Research, 91: 26-34.
- Billington, G. (1989) Fuel use control in fishing industry, p. 112-115, In: Proceedings of the World Symposium on Fishing Gear and Fishing Vessel Design 1988, Marine Institute, St. John’s, Newfoundland, Canada.
- Bjørshol, N.H. (2007) Design concept for low energy fishing vessel, SINTEF Fisheries and Aquaculture, Trondheim, Norway. ICES CM 2007/M:07.
- Boopendranath, M.R and Hameed, M.S. (2009) Energy analysis of traditional non-motorised gill net operations in Vembanad lake, Kerala, India. Fishery Technology 46: 15-20.

- Boopendranath, M.R. and Hameed, M.S. (2010) Energy Analysis of stake net operations in Vembanad lake, Kerala, India. *Fishery Technology* 47: 35-40.
- Boopendranath M.R. and Hameed M. S. (2013) Gross Energy Requirement in Fishing Operations, *Fishery Technology* 50 : 27 – 35.
- Boopendranath, M.R. (1996) Approaches to energy conservation in fishing. In: Study Report, Regional Training Course in Commercial Fishing Technology 1996. TD/RP/39. Training Department, Southeast Asian Fisheries Development Centre, Thailand, 23-31 p.
- Boopendranath, M.R. (2000) Studies on Energy Requirement and Conservation of Selected Fish Harvesting Systems. Ph.D. Thesis. Cochin University of Science and Technology, Cochin, India, 273 p.
- Boopendranath, M.R. (2008) Climate change impacts and fishing practices, Paper presented in Workshop on Impact of Climate Change in Fisheries, 15th December 2008, ICAR, New Delhi.
- Boopendranath, M.R. (2009) Responsible fishing operations. In: Meenakumari, B., Boopendranath, M.R., Pravin, P., Thomas, S.N. and Edwin, L. (eds.), *Handbook of Fishing Technology*. Central Institute of Fisheries Technology, Cochin, 259-295 p.
- Boopendranath, M.R. (2012) Waste Minimisation in Fishing Operations, *Fishery Technology* 49: 109 – 119.
- Botkin, D. B. and Keller, E. A. (2007) *Environmental Science Earth as a living planet*. Santa Barbara: University of California.
- BP Statistical Review (2015). <http://www.bp.com/en/global/corporate/about-bp/energy-economics/statistical-review-of-world-energy/statistical-review-downloads.html>. Accessed on 01 December 2015

- Brandt von, A. (2005) *Fish Catching Methods of the World*, Edited by O. Gabriel, K. Lange, E. Dahm and T. Wendt. 4th Ed. Blackwell Publishing Ltd. UK. 523 p.
- Brown, S. and Lugo, A. E. (1981) *Management and Status of U.S. Commercial Marine Fisheries*. A report published by the Council on Environmental Quality, Washington, D.C.
- Buhaug, Ø., Corbett, J.J., Endresen, Ø., Eyring, V., Faber, J., Hanayama, S., Lee, D.S., Lee, D., Lindstad, H., Markowska, A.Z., Mjelde, A., Nelissen, D., Nilsen, J., Pålsson, C., Winebrake, J.J., Wu, W.Q. and Yoshida, K., (2009) *Second IMO GHG Study*. April 2009. International Maritime Organization (IMO), London, UK, 220 p.
- Burchett, R. (1989) *Vessel management: the second generation*, Paper 2.3, In: *Proceedings of International Fisheries Energy Optimisation Working Group Meeting*, 28-30 August, 1989, University of British Columbia, Vancouver, B.C., Canada.
- Buxton, R. and Robertson, D. (1989) *A Report on the International Fisheries Energy Optimisation Workshop*, August 28-30, 1989, University of British Columbia, Vancouver, B.C., Canada; General Education Series No. 10, Department of Fisheries and Oceans, Atlantic Fisheries Development Program, Ontario, Canada: 21 p.
- C2ES (2015) *Center for Climate and Energy Solutions* <http://www.c2es.org/international/paris-agreement> Accessed on 12 December 2015.
- Calisal, S.M. and McGreer, D. (1989) *Application of a bulbous bow to a fishing vessel*, Paper 3.3, In: *Proceedings of International Fisheries Energy Optimisation Working Group Meeting*, 28-30 August, 1989, University of British Columbia, Vancouver, B.C., Canada.

- Carbon Trust (2008) Department for Environment, Food and Rural Affairs, British Standards Institution. Guide to PAS 2050—How to Assess the Carbon Footprint of Goods and Services; 2008.
- Ceuterick, D (1998) International conference on Life Cycle Assessment in agriculture, agro-industry and forestry - proceedings - 3-4 december 1998 Brussel, Belgium. Mol, VITO.
- Cheung, W. W. L., Pinnegar, J.K., Merino, G., Jones, M.C. and Barange, M. (2012) Review of climate change impacts on marine fisheries in the UK and Ireland. *Aquatic Conservation: Marine and Freshwater Ecosystems* 22: 368-388.
- Cheung, W.W.L., Watson, R. and Pauly, D. (2013) Signature of ocean warming in global fisheries catch. *Nature*, 497(7449), 365-368.
- Chidambaram, K. (1952) The experimental introduction of powered fishing vessels in India and Ceylon, *Proceedings of Indo Pacific Fisheries Council* 4(2): 225-233.
- Choudhury, R.L.R. (1993) Design of small gillnetter/longliner, In: *Proceedings of the National Workshop on Low Energy Fishing, Fishery Technology, Special Issue, Society of Fisheries Technologists, Cochin, India.* p. 71-73.
- Christensen, V., Guenette, S., Heymans, J. J., Walters, C. J., Watson, R., Zeller, D. and Pauly, D. (2003) Hundred-year decline of North Atlantic predatory fishes. *Fish and Fisheries*, 4(1): 1–24.
- Chuenpagdee, R., Morgan, L.E., Maxwell, S.M., Norse and E.A., Pauly, D. (2003) Shifting gears: assessing collateral impacts of fishing methods in US waters. *Frontiers in Ecology and the Environment* 1 (10): 517–524.
- CMFRI (1969) Marine Fish Production in India (1950-1968). *Bulletin Central Marine Fisheries Research Institute* Number 13.

- CMFRI (1981) All India census of marine fishermen, craft and gear: 1980. Marine Fisheries Information Service; Technical and Extension Series, No. 30: 1-32.
- CMFRI (2006) Marine fisheries census 2005 Part-1, Central Marine Fisheries Research Institute, Cochin, 97 p.
- CMFRI (2012) Marine Fisheries Census 2010 Part I India, Department of Animal Husbandry, Dairying & Fisheries and CMFRI 98 p
- CMFRI (2013a) Annual Report 2012-13. Central Marine Fisheries Research Institute, Cochin. 200 p.
- CMFRI (2013b) Data set on marine fish landings from single-day and multi-day trawlers and unit operations during June 2012 - May 2013 obtained from Fishery Resource Assessment Division of Central Marine Fisheries Research Institute, Cochin.
- CMFRI (2014) Annual Report 2013-14. Central Marine Fisheries Research Institute, Cochin. 274 p.
- CMFRI (2015) Annual Report 2014-15. Central Marine Fisheries Research Institute, Cochin. 279 p.
- Curtis, H. C., Graham, K. and Rossiter, T. (2006) Options for Improving Fuel Efficiency in the UK Fishing Fleet. Seafish. ISBN 0 903 941 597.
- DADF (2013) <http://www.dahd.nic.in/dahd/WriteReadData/Fisheries%20Profile%20of%20India%2015.7.2013.pdf>. Accessed on 02 January 2014.
- Das, D.P.H. (pers. comm.) Personal communication pertaining to Ph.D. thesis titled Investigations on the structural and operational changes of ring seine fishing systems of Kerala and its Life Cycle Assessment (LCA) submitted to CUSAT, Cochin.

- Devaraj, M., Kurup, M.N., Pillai, N.G.K., Balan, K., Vivekanadan, E. and Sathiadas, R. (1997) Small pelagic resources and their fisheries in the Asia Pacific region. In: Devaraj, M., Martosubroto, P. (Eds.). RAP publications, 91-138 p.
- Devaraj, M. and Vivekanandan, E. (1999) Marine capture fisheries of India: challenges and opportunities. *Current Science* 76: 314-332.
- Dickson, W. (1989) Energy saving in fisheries and evaluation of its effects, In: Proceedings of the World Symposium on Fishing Gear and Fishing Vessel Design 1988, Marine Institute, St. John's, Newfoundland, Canada. p. 93-98.
- DOF (2007) Report of the Expert Committee for impact assessment of ban on bottom trawling imposed along Kerala coast. Directorate of Fisheries, Government of Kerala, Thiruvananthapuram, ix+292 p.
- Driscoll, J. and Tyedmers, P. (2010) Fuel use and greenhouse gas emission implications of fisheries: management the case of the New England Atlantic herring fishery. *Marine Policy* 34 (3): 353–359.
- EC/JRC (2007) Carbon footprint: what it is and how to measure it. Ispra: European Platform on Life Cycle Assessment European Commission – Joint Research Centre Institute for Environment and Sustainability.
- Edwardson, W. (1976) The energy cost of fishing, *Fishing News International*. 15(2): 36-39.
- Edwin, L. and Hridayanathan, C. (1997) Energy efficiency in the ring seine fishery of south Kerala coast, *Indian Journal of Fisheries* 44 (4):387-392
- Edwin (2013) CIFT's Initiatives towards development of Green Fishing Systems for Indian waters, Paper presented in ICES- FAO WGFTFB in 2013 annual meeting of the working group on fishing technology and fish behaviour, 6 May 2013, SEAFDEC, Bangkok, Thailand.

- Edwin, L., Thomas, S.N., Pravin, P., Remesan, M.P., Madhu, V.R., Biju, M.V., Sreejith, P.T., Ravi, R. and Das, D.P.H. (2014a) CIFT Fishing System Catalogue 1- Mechanised Marine Fishing Systems: Kerala, Central Institute of Fisheries Technology, Kochi, 113 p.
- Edwin, L., Pravin, P., Madhu, V.R., Thomas, S.N., Remesan, M.P., Baiju, M.V., Ravi, R., Das, D.P.H., Boopendranath, M.R. and Meenakumari, B. (2014b) Mechanised Marine Fishing Systems: India, Central Institute of Fisheries Technology, Kochi, 277 p.
- E-fishing, (2010) First International Symposium on Fishing Vessel Energy Efficiency Vigo, Spain Retrieved 9 Nov, 2011, from <http://www.e-fishing.eu/>
- EPLCA (2007) Carbon footprint - what it is and how to measure it. European Platform on Life Cycle Assessment, European Commission.
- Ellingsen, H. and Aanonsen, S. (2006) Environmental impacts of wild caught cod and farmed salmon - a comparison with chicken. *The International Journal of Life Cycle Assessment*. 11 (1), 60–65.
- Emanuelsson, A., Flysjö, A., Thrane, M., Ndiaye, V., Eichelsheim, J.L. and Ziegler, F. (2008) Life Cycle Assessment of southern pink shrimp products from Senegal. In: 6th International Conference on Life Cycle Assessment in the Agri-Food Sector, Zurich, 1-9 p.
- Endal, A. (1980) Fuel saving, *Fishing News International* 19(10): 16-17.
- Endal, A. (1989a) Energy fishing - challenge and opportunities, p. 74-78, In: *Proceedings of the World Symposium on Fishing Gear and Fishing Vessel Design 1988*, Marine Institute, St. John's, Newfoundland, Canada
- Endal, A. (1989b) Future outlook-vessels, Keynote paper-Session 3, In: *Proc. International Fisheries Energy Optimisation Working Group Meeting*,

- 28-30 August, 1989, University of British Columbia, Vancouver, B.C. Canada.
- Enerhaug, B. (1989) The effect of lengthening of a fishing vessel on its sea-keeping performance, In: Proceedings of the World Symposium on Fishing Gear and Fishing Vessel Design 1988, Marine Institute, St. John's, Newfoundland, Canada, p. 87-92.
- Espadafor, F. J. García, M. T., Villanueva, J. B. and Gutierrez, J. M. (2009): The viability of pure vegetable oil as an alternative fuel for large ships, Transportation Research Part D 14: 461 - 469.
- European Environment Agency (1997) Life Cycle Assessment- A guide to approaches, experiences and information sources. Folkmann Design & Promotion.
- Eyjólfsdóttir, H., Yngvadóttir, E., Jónsdóttir, H. and Skúladóttir, B. (2003) Environmental effects of fish on the consumers dish – life cycle assessment of Icelandic frozen cod products. IFL Report 06-03, Reykjavik. Iceland, Technological Institute of Iceland and Icelandic Fisheries Laboratories: 40.
- FAO (1974) Otter Board Design and Performance, FAO Fishing Manual, FAO, Rome: 82 p.
- FAO (1975) Catalogue of Small-scale Fishing Gear. Fishing News Books Ltd., Farnham, 191 p.
- FAO (1978) FAO Catalogue of Fishing Gear Designs, Fishing News Books Ltd., Farnham: 159 p.
- FAO (1981) Energy and Other Costs in Fisheries, FAO COFI/81/Inf-9, FAO, Rome: 8 p.
- FAO (1995) Code of Conduct for Responsible Fisheries, FAO, Rome, 41 p.

- FAO (2007) The State of World Fisheries and Aquaculture 2006. FAO, Rome, 162 p.
- FAO (2009) The State of World Fisheries and Aquaculture - 2008. Rome, Food and Agriculture Organization of the United Nations.
- FAO (2012a) The State of World Fisheries and Aquaculture (SOFIA) 2012, FAO, Fisheries and Aquaculture Department, Rome. <http://www.fao.org/docrep/016/i2727e/i2727e00.htm>, Accessed on 1st June 2013, 209 p.
- FAO (2012b) <http://www.fao.org/figis/servlet/SQServlet?ds=Production&k1=COUNTRY&k1v=1&k1s=100&outtype=html>. Accessed on 2nd June 2013
- FAO (2013) Global capture fisheries production statistics 2011. <ftp://ftp.fao.org/fi/news/GlobalCaptureProductionStatistics2011.pdf>. Accessed on 1 June 2013 4 p.
- FAO (2014) The State of World Fisheries and Aquaculture (SOFIA) 2014, FAO, Rome. 223 p.
- Feng, M., (2010) Impact of MARPOL Annex VI Regulations on Marine Fuels Supply, Southwest Research Institute, San Antonio
- Fréon, P., Avadí, A., Chavez, R.A.V. and Ahón, F.I. (2014) Life cycle assessment of the Peruvian industrial anchoveta fleet: boundary setting in life cycle inventory analyses of complex and plural means of production, *The International Journal of Life Cycle Assessment* 19 (5): 1068-1086.
- Fridman, A.L. (1986) Calculations for Fishing Gear Designs, FAO Fishing Manual, Fishing News Books Ltd., Farnham: 241 p.
- Fridman, A.L. (1989) The problems of fisheries energy optimisation, Paper 1.2, In: Proc. International Fisheries Energy Optimisation Working Group Meeting, 28-30 August, 1989, University of British Columbia, Vancouver, B.C., Canada.

- Fridman, A.L. and Lissovoy, A.P. (1989) Computer assisted design system of fishing technology (SAPR), In: Proceedings of the World Symposium on Fishing Gear and Fishing Vessel Design 1988, Marine Institute, St. John's, Newfoundland, Canada, p. 116-118.
- Froese, R. and Pauly, D. (eds) (2000) FishBase 2000: Concepts, Design and Data sources, ICLARM, Los Banos, Philippines, 346 p.
- Frostad, R. (1989) Modern hull form of fishing vessels, Paper 3.2, In: Proceedings of International Fisheries Energy Optimisation Working Group Meeting, 28-30 August, 1989, University of British Columbia, Vancouver, B.C., Canada.
- Fyson, J.F. (1982) Low energy fishing vessels: the use of sails, In: May, R.C., Smith, I.R. and Thomson, D.B. (Eds.) (1982) Appropriate Technology for Alternative Energy Sources in Fisheries, Proceedings of the ADB-ICLARM Workshop On Appropriate Technology for Alternative Energy Sources in Fisheries, Manila, Philippines, 21-24 February, 1981, ICLARM Conference Proceedings 8. p. 15-47.
- Fyson, J. (Ed.) (1985) Design of Small Fishing Vessels, Fishing News Books Ltd, Farnham, Surrey, England: 319 p.
- Fyson, J.F. (1991) Fishing Boat Designs 3 Small Trawlers, FAO Fisheries Technical Paper 188: 51 p.
- Gallene, J. (1993) Offshore low energy fishing technology in the Bay of Bengal, In: Proceedings of the National Workshop on Low Energy Fishing, Fishery Technology, Special Issue, Society of Fisheries Technologists, Cochin, India, p. 179-182.
- Gardner, W.J. (1989) Measuring performance characteristics of medium speed propulsion environment, In: Proceedings of the World Symposium on

- Fishing Gear and Fishing Vessel Design 1988, Marine Institute, St. John's, Newfoundland, Canada, p. 99-111.
- George, C.S. (1993) Prospects and performance of deep sea fishing vessels for low energy fishing techniques, In: Proceedings of the National Workshop on Low Energy Fishing, Fish. Technol., Special Issue, Society of Fisheries Technologists, Cochin, India, p. 79-81.
- George, V.C., Vijayan, V., Varghese, M.D., Radhalakshmi, K., Thomas, S.N. and Joseph, J. (eds). (1993) Proceedings of the National Workshop on Low Energy Fishing, 8–9 August, 1991. Society of Fisheries Technologists (India), Cochin, 286 p.
- Gerber, P., Vellinga, T., Opio, C., Henderson, B. and Steinfeld, H. (2010) Greenhouse Gas Emissions from the Dairy Sector, a Life Cycle Assessment. Rome, Italy: Food and Agriculture Organisation of the United Nations, Animal Production and Health Division.
- Ghosh, S., Rao, H.M.V., Kumar, S.M., Mahesh, U.V., Muktha, M. and Zacharia, P. U. (2014) Carbon footprint of marine fisheries: life cycle analysis from Visakhapatnam, *Current Science*, 107 (3): 515-521.
- Gifford, E.W.H (1982) Development of low energy fishing boats for tropical use, In: May, R.C., Smith, I.R. and Thomson, D.B. (Eds.) (1982) *Appropriate Technology for Alternative Energy Sources in Fisheries*, Proceedings of the ADB-ICLARM Workshop on Appropriate Technology for Alternative Energy Sources in Fisheries, Manila, Philippines, 21-24 February, 1981, ICLARM Conf. Proc. 8, p. 55-63.
- Glass, C.W. (2000) Conservation of fish stocks through bycatch reduction: a review. *Northeastern Naturalist* 7 (4): 395–410.

- GOI (2011) Report of the Working Group on development and management of fisheries and aquaculture, for the XII Five Year Plan (2012-17). Planning Commission, Government of India, New Delhi, 147 p.
- Goudey, C.A. and Venugopal, M. (1989) Roll reduction on fishing vessels using bilge keels and passive bilge fins, In: Proceedings of the World Symposium on Fishing Gear and Fishing Vessel Design 1988, Marine Institute, St. John's, Newfoundland, Canada, p. 79-86.
- Grofit, E. (1981) The fuel problem in trawl industry, Fish. Fishbreed. Isr. 16(2): 28-35.
- Guinée, J.B., Gorrée, M., Heijungs, R., Huppes, G., Kleijn, R., de Koning, A., van Oers, L., Wegener, A., Suh, S., Udo de Haes, H.A. (2001). Life Cycle Assessment. An Operational Guide to the ISO Standards. Centre of Environmental Science, Leiden, The Netherlands.
- Gulbrandsen, O. (1986) Reducing Fuel Cost of Small Fishing Boats, BOBP/WP/27, Bay of Bengal Programme, Madras:15 p.
- Gulbrandsen, O. (2012) Fuel savings for small fishing vessels – A manual, FAO, Rome, 57 p.
- Guttormsdóttir, A. B. (2009) Life Cycle Assessment on Icelandic cod product based on two different fishing methods, Environmental impacts from fisheries, Sigillium Universitatis Islandiae, Verkfræðideild Háskóli Íslands, 106 p.
- Guyonnet, B., Grall, J. and Vincent, B. (2008). Modified otter trawl legs to reduce damage and mortality of benthic organisms in North East Atlantic fisheries (Bay of Biscay). Journal of Marine Systems 72, 2–16.

- Halberg, N, Ed. (2004) Dias report - life cycle assessment in the agri-food sector - proceedings from the 4th international conference, October 6-8, 2003, Bygholm, Denmark. Tjele, Denmark, DIAS Foulum.
- Hall-Spencer, J., Allain, V. and Fossa, J.H. (2002) Trawling damage to Northeast Atlantic ancient coral reefs. *Proceedings of the Royal Society of London*, 269: 507–511.
- Hameed, M.S. and Hridayanathan, C. (1989) Energy consumption pattern of fishing boats operating in the inshore waters of the south-west coast of India, Paper 1.4, In: *Proceedings of International Fisheries Energy Optimisation Working Group Meeting*, 28-30 August, 1989, University of British Columbia, Vancouver, B.C., Canada.
- Hameed, M.S. and Boopendranath, M.R. (2000) *Modern Fishing Gear Technology*, Daya Publishing House, Delhi: 186 p.
- Hameed, M.S. and Kumar, K.A. (1993) Problems of energy optimisation in fisheries, In: *Proceedings of the National Workshop on Low Energy Fishing*, Fish. Technol., Special Issue, Society of Fisheries Technologists, Cochin, India. p. 91-92.
- Harrison, R. M. (1990) *Pollution: Causes, effects and control* (2nd ed.). Cambridge, UK: The Royal Society of Chemistry.
- Hayman, B., Dogliani, M., Kvale, I. and Fet, A.M. (2000). Technologies for reduced environmental impact from ships—Ship building, maintenance and dismantling aspects. ENSUS-2000, Newcastle upon Tyne, UK.
- He, P. and Winger, P.D. (2010) Effect of trawling on the seabed and mitigation measures to reduce impact. In: He, P. (Ed.), *Behavior of Marine Fishes: Capture Processes and Conservation Challenges*. Blackwell Publishing, 295–314 p.

- Heredia-Quevedo, J.A., (2010) Fuel saving: the goal in designing fishing nets. In: Proceedings of the National Oceanic and Atmospheric Administration Symposium on Energy use in Fisheries: Improving Efficiency and Technological Innovations from a Global Perspective, Seattle, WA, USA, 14–17 November 2010.
- Hopper, A. G. (1982) Energy Efficiency in Fishing Vessels. In. Fishing Industry Energy Conservation Conference. The Society of Naval Architects and Marine Engineers, New York. 55-82 p.
- Hornborg, S., Nilsson, P., Valentinsson, D. and Ziegler, F. (2012) Integrated environmental assessment of fisheries management: Swedish Nephrops trawl fisheries evaluated using a life cycle approach. *Marine Policy* 36: 1193-1201.
- Hospido, A., and Tyedmers, P. (2005). Life cycle environmental impacts of Spanish tuna fisheries. *Fisheries Research*, 76: 174-186.
- Hospido, A., Vazquez, M.E., Cuevas, A., Feijoo, G. and Moreira, M.T. (2006) Environmental assessment of canned tuna manufacture with a life-cycle perspective. *Resources, Conservation and Recycling* 47(1): 56-72
- Houghton, J.T., Callander, B.A. and Varney, S.K. Eds. (1992) Climate change 1992 - the supplementary report to the IPCC scientific assessment IPCC supplement. Cambridge, UK, Cambridge University Press.
- Houghton, J.T., Ding, Y., J, G.D., Noguer, M., van der Linden, P.J. and Xiaosu, D. Eds. (2001) Climate change 2001 - the scientific basis - contribution of working group i to the third assessment report of the intergovernmental panel on climate change (IPCC). IPCC third assessment report: Climate change 2001. Cambridge, UK, Cambridge University Press.
- Houghton, J.T., Jenkins, G.J. and Ephraums, J.J., Eds. (1990) Scientific assessment of climate change - report of working group i IPCC first

- assessment report.1990: Climate change. Cambridge, Cambridge University Press.
- Houghton, J.T., Meira Filho, L.G., Callander, B.A., Harris, N., Kattenberg, A. and Maskell, K. Eds. (1995) Climate change 1995 - the science of climate change. IPCC second assessment report: Climate change 2005. Cambridge, UK, Cambridge University Press.
- Huse, I., Aanonsen, S., Ellingsen, H., Engas, A., Furevik, D., Graham, N., Isaksen, B., Jørgensen, T., Løkkeborg, S., Nøttestad, L. and Soldal, A.V. (2002). A Desk-study of Diverse Methods of Fishing when Considered in Perspective of Responsible Fishing, and the Effect on the Ecosystem Caused by Fishing Activity. Institute of Marine Research and SINTEF, Bergen, Norway.
- ICAR (2011) Handbook of Fisheries and Aquaculture. Directorate of Knowledge Management in Agriculture, Indian Council of Agricultural Research, New Delhi, 1116 p.
- IEA (1993) Fishing Vessel Energy Efficiency Meeting, 25-26 March 1993, Vancouver, British Columbia, Canada, International Energy Agency, Fisheries and Oceans, Fishing Industry Services, Canada: 13 p.
- IOCL (2015) <https://iocl.com/Products/DieselDomesticPrices.aspx> Accessed on May 2015.
- Iribarren, D., Vázquez-Rowe, I., Hospido, A., Moreira, M.T. and Feijoo, G. (2010a) Estimation of the carbon footprint of the Galician fishing activity (NW Spain). *Science of the Total Environment*, 408 (22): 5284–5294

- Iribarren, D., Vázquez-Rowe, I., Moreira, M. T., & Feijoo, G. (2011) Updating the carbon footprint of the Galician fishing activity (NW Spain). *Science of the Total Environment*, 409: 1609-1611.
- Ishida, O., Watanabe, K., Yano, T. and Tahara, K. (2008) Life cycle assessment for saury industry from fishery to consumption. The Eighth International Conference on EcoBalance - The challenge of creating social and technological innovation through system-thinking, Tokyo, Dec. 10-12, 2008, The Institute of Life Cycle Assessment.
- Ishikawa, M., Sato, K., Akizawa, H., Sakai, Y. and Watanabe, H. (1987) A case study of energy analysis of long distance squid angling. *Bulletin of the Japanese Society of Scientific Fisheries/Nippon Suisan Gakkaishi*, 53(9):1525-1531.
- ISO (2006a) ISO 14040:2006, Environmental management-Life Cycle Assessment-Principles and framework. International Organization for Standardization.
- ISO (2006b) ISO 14044:2006, Environmental management-Life Cycle Assessment-Requirements and guidelines. International Organization for Standardization.
- Jackson, J.B.C., Kirby, M.X., Berger, W.H., Bjorndal, K.A., Botsford, L.W., Bourque, B.J., Bradbury, R.H., Cooke, R., Erlandson, J., Estes, J.A., Hughes, T.P., Kidwell, S., Lange, C.B. and Warner, R.R. (2001). Historical overfishing and the recent collapse of coastal ecosystems. *Science* 293: 629–638.
- Jiang, I.J. (1982) Development of low-energy fishing boats in Taiwan, In: May, R.C., Smith, I.R. and Thomson, D.B. (Eds.) *Appropriate Technology for Alternative Energy Sources in Fisheries*, Proceedings of the ADB-

- ICLARM Workshop on Appropriate Technology for Alternative Energy Sources in Fisheries, Manila, Philippines, 21-24 February, 1981, ICLARM Conference Proceedings, 8. p. 71-74.
- John, A.T. (1996) Energy Optimisation Studies in Trawling Operations along Kerala Coast, Ph.D. Thesis, Cochin University of Science and Technology, Cochin: 213 p.
- John, A.T., Hameed, M.S., Ravindran, K. and Iyer, H.K. (1998) Energy efficiency with reference to energy yield of trawlers, In: Balachandran, K.K., Iyer, T.S.G., Madhavan, P., Joseph, J., Perigreen, P.A., Raghunath, M.R. and Varghese, M.D. (Eds.) Advances and Priorities in Fisheries Technology, Society of Fisheries Technologists (India), Cochin. p. 419-425.
- Johnson, K. (2002) Review of national and international literature on the effects of fishing on benthic habitats. NOAA Technical Memorandum NMFS F/SPO, no. 57, Maryland, USA.
- Kaiser, M., Attrill, M., Jennings, S., Thomas, D., Barnes, D., Brierley, A., Polunin, N., Raffaelli, D. And Williams, P. (2005) Marine Ecology, Processes, Systems and Impacts. Oxford: Oxford University Press.
- Kelleher, K. (2005) Discards in world's marine fisheries, an update. FAO 2005, Fisheries Technical Paper No. 470.
- Kohane, A. and Ben-Yami, M. (1989) Energy saving in small trawlers through improvements in propulsion systems, Paper 4.3, In: Proc. International Fisheries Energy Optimisation Working Group Meeting, 28-30 August, 1989, University of British Columbia, Vancouver, B.C., Canada.
- Kristjonnsson, H. (1967) Technique of finding and catching shrimp in commercial fishing, Proceedings of FAO World Scientific Conference

- on the Biology and Culture of Shrimps and Prawns, 12-24 June 1967, Ciudad de Mexico: 69 p.
- Kunjipalu, K.K., Pillai, N.S. and Boopendranath, M.R. (1989) Performance of 25 m large mesh demersal trawl, *Fisheries Technology* 26(2): 95-99.
- Kunjipalu, K.K., Boopendranath, M.R., Pillai, N.S., Varghese, M.D., Mathai, T.J. and Meenakumari, B. (1998) Large mesh demersal and high opening trawls for finfish and cephalopods, In: Balachandran, K.K., Iyer, T.S.G., Madhavan, P., Joseph, J., Perigreen, P.A., Raghunath, M.R. and Varghese, M.D. (Eds.) *Advances and Priorities in Fisheries Technology*, Society of Fisheries Technologists (India), Cochin. p. 160-164.
- Kurup, K.N. and Devaraj, M. (2000) Estimates of optimum fleet size for the exploited Indian shelf fisheries. *Marine Fisheries Information Service, Technical and Extension Series*, 165: 2-11.
- Kurup, N.S., Sarada, P.T., Menon, K.K. and Lakshmi, S. (1993) Low energy fishing methods for the prawn fishery of Calicut, Kerala, In: *Proceedings of the National Workshop on Low Energy Fishing, Fishery Technology, Special Issue*, Society of Fisheries Technologists, Cochin, India. p. 130-136.
- Kurup, B.M., Purushan, K.S., Pillai, N.G.K., Boopendranath, M.R., Lathy, K.M., Mony, P.R., Saira Banu, Sahadevan, P., Anithakumari, D., Sandhia, R. 2009. Report of the expert committee for the registration of fishing vessels, Directorate of Fisheries, Govt. of Kerala, Thiruvananthapuram, xi+189 p.
- Kwidzinski, Z. (1989) Development of pelagic trawl construction aimed at fisheries energy optimisation, Paper 2.1, In: *Proceedings International*

- Fisheries Energy Optimisation Working Group Meeting, 28-30 August, 1989, University of British Columbia, Vancouver, B.C., Canada.
- Leach, G. (1976) Energy and food production. IPC Science and Technology Press, Surrey.
- Lee, K.S. and Son, Y.I. (1982) Combining sail and power in fishing vessels, p. 71-74, In: May, R.C., Smith, I.R. and Thomson, D.B. (Eds.) (1982) *Appropriate Technology for Alternative Energy Sources in Fisheries*, Proceedings of the ADB-ICLARM Workshop on Appropriate Technology for Alternative Energy Sources in Fisheries, Manila, Philippines, 21-24 February, 1981, ICLARM Conference Proceedings, 8.
- Loeng, H. and Furevik, T. (2005) Et klima i endring. Havets ressurser og miljø. Bergen, Havforskningsinstituttet / Institute of Marine Research, 183-185 p.
- Lorentzen, G. (1978) Energy account of the Norwegian fishing sector. *Meldingen SSFM2*, 5–9.
- Lorentzen, T. and Hannesson, R. (2005) Klimaendring, global oppvarming og konsekvenser for norsk fiskeri- og oppdrettsnæring. *SNF Bulletin*. 17: 4-10.
- Madhu, V.R. and Panda, S.K. (2009) Effect of Tow Duration and Speed on the Capture Efficiency of Bottom Trawl, *Fishery Technology*, 46 (1): 25-32.
- Magnusson, B. (1989) New design and redesign of Icelandic fishing vessels results in better performances and less fuel consumption, In: *Proceedings of the World Symposium on Fishing Gear and Fishing Vessel Design 1988*, St. John's, Canada p. 581-583.
- Marlen, B.V. (1989a) A decade of research and development of mid-water trawls in the Netherlands, In: *Proceedings of the World Symposium on Fishing Gear and Fishing Vessel Design 1988*, Marine Institute, St. John's, Newfoundland, Canada. p. 141-153.

- Marlen, B.V. (1989b) The energy saving potential of high strength materials in super-mesh trawls, Paper 2.2, In: Proceedings of International Fisheries Energy Optimisation Working Group Meeting, 28-30 August, 1989, University of British Columbia, Vancouver, B.C., Canada.
- Marlen, B.V and P. Salz (2010) Energy Saving in Fisheries – EU project ESIF, First International Symposium on Fishing Vessel Energy Efficiency E-Fishing, Vigo, Spain, May 2010, 4 p.
- Marlen, B.V. (Ed.), (2009) Energy Saving in Fisheries (ESIF) FISH/2006/17LOT3-Final Report. IMARES, Report No. C002/08, 425 p.
- Mathew, P.M., Aegisson, G. and Sasikumar, P.K. (1992) The Economics of Energy in Marine Fisheries- Study on the Lower South-west Coast of India, Norwegian Marine Technology Research Institute, Trondheim, Norway and Institute of Small Enterprises and Development, Cochin: 76 p.
- May, R.C., Smith, I.R. and Thomson, D.B. (eds.) (1981) Appropriate Technology for Alternative Energy Sources in Fisheries. ICLARM Conf. Proc. 8, ICLARM, Manila, 215 p.
- McCay, B.J., Brandt, S. and Creed, C.F. (2011) Human dimensions of climate change and fisheries in a coupled system: the Atlantic surfclam case. ICES Journal of Marine Science 68: 1354-1367.
- McIlwaine, R.H. (1989) Final report on the design, full scale testing of bulbous and winged type net guard aboard FV Kynoc, Paper 3.7, In: Proceedings International Fisheries Energy Optimisation Working Group Meeting, 28-30 August, 1989, University of British Columbia, Vancouver, B.C., Canada.
- McIlwaine, R.H., Calisal, S.M., Gamski, Z.W., McGreer, D. and Chu, C.Y. (1989) Computer analysis and model testing of trawls for improved energy efficiency, p. 132-140, In: Proceedings of the World

- Symposium on Fishing Gear and Fishing Vessel Design 1988, Marine Institute, St. John's, Newfoundland, Canada.
- Ministry of Statistics and Programme Implementation (2011) CSO-MFS-2011 Manual on Fishery Statistics http://mospi.nic.in/mospi_new/upload/manual_fishery_statistics_2dec11.pdf.
- Mitchell, C. and Cleveland, C. J. (1993) Resource Scarcity, Energy Use and Environmental Impact: A Case study of the New Bedford, Massachusetts, USA, Fisheries. *Environmental Management*, 17(3):305-317.
- Mohamed, K.S., Puthra, P. Sathianandan, T.V. Baiju, M.V. Sairabanu, K.A. Lethy, K.M. Sahadevan, P., Chandrasekharan Nair, Lailabeevi and M., Sivaprasad P.S. 2013. Report of the committee to evaluate fish wealth and impact of trawl ban along Kerala coast. Department of Fisheries, Government of Kerala, 68 p.
- Mohanrajan, K.V. (1987) Energy alternatives in fisheries sector, *Fishing Chimes* 6(11): 45-50.
- MPEDA (2012) Statistics of marine products 2010, The Marine Product Export Development Authority, Ministry of Commerce and Industry, Govt. of India, 1-677 p.
- MPEDA (2013) The Marine Products Export Development Authority, MARINE PRODUCTS EXPORTS REACH RS. 18,856 CRORES IN 2012-13, Ministry of Commerce, Government of India, Cochin, <http://www.mpeda.com/Press.pdf>.
- MPEDA (2015) The Marine Products Export Development Authority, Indian Seafood exports crossed 5.5 Billion US\$, Ministry of Commerce, Government of India, Cochin, http://164.100.150.120/mpeda/news_details.php?pg=indian-seafood-exports-crossed-5-5-billion-us#.

- Mukundan, M. and Hameed, M.S., (1993). Present status of Trawl Designs in Cochin area. *J. Mar. Biol. Ass. India.* 35 (1 & 2): 109-113.
- Mungkung, R.T. (2005). Shrimp aquaculture in Thailand: Application of life cycle assessment to support sustainable development. Centre for Environmental Strategy, School of Engineering, University of Surrey: XVI,243.
- Mungkung, R.T., Udo de Haes, H.A. and Clift, R. (2006) Potentials and limitations of life cycle assessment in setting ecolabelling criteria: A case study of thai shrimp aquaculture product. *The International Journal of Life Cycle Assessment* 11(1): 55-59.
- Myers, R.A. and Worm, B. (2003) Rapid worldwide depletion of predatory fish communities. *Nature*, 423: 280-283.
- Nedlec, C. (1982) Definition and classification of fishing gear categories. *FAO Fisheries Technical Paper* 222: 1-51.
- Nellemann, C., Hain, C., and Alder, J. (2008) *In Dead Water - Merging of Climate Change With Pollution, Over-Harvest, and Infestations In The World's Fishing Grounds-.Norway: United Nations Environment Programme.*
- Nemecek, T. (2008) Book of abstract. 6th International Conference on Life Cycle Assessment in the Agri-Food Sector - Towards a Sustainable Management of Food chains, Zürich, Switzerland, Agroscope Reckenholz-Tänikon Research Station ART.
- Nomura, M. (1980) Influence of Fish Behavior on Use and Design of Setnets. In: *Fish behavior and its use in the capture and culture of fishes* Ed. by J.E., J.J. Magnuson, R.C. May and J.M. Reinhart. ICLARM Conference

- Proceedings 5,. International Center for Living Aquatic Resources Management, Manila, Philippines. 446-472 p.
- Norden (2008) Aðgangsharðar fiskveiðar skaða lífríkið á hafsbotni. Reykjavík: Norrænt umhverfissamstarf.
- Notarnicola, B., Settanni, E., Tassielli, G. and Guingato, P. Eds. (2010) LCA food 2010 - vii international conference on life cycle assessment in the agri-food sector, Bari, Italy, September 22-24, 2010. Proceedings. Bari, Università degli Studi di Bari.
- Parente, J., Fonseca, P., Henriques, V. and Campos, A. (2008) Strategies for improving fuel efficiency in the Portuguese trawl fishery. *Fisheries Research* 93: 117–124.
- Parker, R.W.R. and Tyedmers, P. (2012) Life cycle environmental impacts of products derived from Antarctic krill (*Euphasia superba*). *Environmental Science and Technology*. 46(9):4958–4965.
- Parker, R.W.R. and Tyedmers, P. (2015) Fuel consumption of global fishing fleets: Current understanding and knowledge gaps. *Fish and Fisheries*. 16(4): 684–696.
- Parrish, B.B. (1975) Midwater trawls and their operation. In: *Modern Fishing Gear of the World*, Fishing News Books Ltd. London. (Kristjónsson, H., Eds.) 1: 333-343
- PAS 2050 (2011) Specification for the assessment of the life cycle greenhouse gas emissions of goods and services, BIS, 45p.
- Pauly, D. and Maclean, J. (2003) *In a Perfect Ocean: The State of Fisheries and Ecosystems*. Island Press, Washington, DC, 175 p.
- Pauly, D., Alder, J., Bennett, E., Christensen, V., Tyedmers, P. and Watson, R. (2003) The future for fisheries. *Science* 302: 1359–1361.

- Pauly, D., Christensen, V., Guenette, S., Pitcher, T.J., Sumaila, R.U., Walters, C.J., Watson, R., Zeller, D. (2002). Towards sustainability in world fisheries. *Nature* 418: 689–695.
- Pelletier, N.L., Ayer, N.W., Tyedmers, P. H., Kruse, S. A., Flysjo, A., Robillard, G., Ziegler, F., Scholz, A. J. and Sonesson, U. (2007) Impact categories for Life Cycle Assessment research of seafood production systems: Review and prospectus. *The International Journal of Life Cycle Assessment*, 12(6): 414-421.
- Pelletier, N., Tyedmers, P., Sonesson, U., Scholz, A., Ziegler, F., Flysjo, A., Kruse, S., Cancino, B. and Silverman, H. (2009) Not all salmon are created equal: Life Cycle Assessment (LCA) of global salmon farming systems." *Environmental Science & Technology* 43(23): 8730-8736.
- Pillai N.G.K., Vivekanandan E., Ganga U. and Ramachandran, C. (2009) Marine Fisheries Policy Brief 1: Kerala. CMFRI Special Publication 100: 1-24.
- Pillai, S.A. and Namboodiri, K.S. (1993) Problems in mechanisation of low energy fishing craft for coastal waters, In: *Proceedings of the National Workshop on Low Energy Fishing*, Fish. Technol., Special Issue, Society of Fisheries Technologists, Cochin, India. p. 84-86.
- Pillai, N.S., Varghese, M.D. and Mathai, T.J. (2004). Performance evaluation of different types of selective devices for reduction of bycatch in shrimp trawl, In: Somvanshi, V.S. (Ed.) *Large Marine Ecosystems: Exploration and Exploitation for Sustainable Development and Conservation of Fish Stocks*, Fishery survey of India, Mumbai, 569-576.

- Pimentel, D., Shanks, R.E. and Rylander, J.C. (1996) Bioethics of fish production: energy and the environment. *Journal of Agricultural and Environmental Ethics*, 9(2): 144–164.
- Pinhorn (1986) Vessel analysis computing system (Ener Sea), Canadian Technical Report of Fisheries and Aquatic Sciences, 1529: 39 p.
- Pinsky, M.L. and Fogarty, M. (2012) Lagged social-ecological responses to climate and range shifts in fisheries. *Climate Change* 115: 883-891.
- Pravin, P. (2001) Square mesh cod end in demersal trawls for conservation and management of marine resources Workshop on Marine fisheries of Karnataka: Resources and development opportunities, Mangalore, 21-22 December
- Pravin, P., Madhu, V.R., Remesan, M.P., Baiju, M.V. and Boopendranath, M.R. (2012) Large Mesh Demersal Trawls in India : An Update, *Fishing chimes*, 32(5) : 43-45.
- Rajeswari, G., Raghu Prakash, R. and Sreedhar, U. (2012) Trawl Designs Used in Small-scale Mechanised Fisheries Sector of Andhra Pradesh, India, *Fishery Technology*, 49(1) 18-27
- Ragnarsson, E. (1979) Brennsluoliunotkun íslenskra fiskiskipa (Fuel Oil Use by Icelandic Fishing Boats). *Ægir*, 72(12): 726-731 (In Icelandic).
- Ragnarsson, E. (1985) Orkunotkun - Orkusparnaður. Fisheries Association of Iceland and the Ministry of Fisheries, Reykjavík, Iceland. 15p.
- Rajasenan, D. (1987) The fishing industry in Kerala problems and potentials, Ph.D. Thesis. Cochin University of Science and Technology Cochin, India, 414p
- Ramos, S., Vázquez-Rowe, I., Artetxe, I., Moreira, M.T., Feijoo, G. and Zufía, J. (2011) Environmental assessment of the Atlantic mackerel

- (*Scomber scombrus*) season in the Basque Country. Increasing the timeline delimitation in fishery LCA studies. *The International Journal of Life Cycle Assessment*, 16 (7), 599–610.
- Rao, S.V.S.R. and Narayanappa, G. (1994) Performance of 25 m rope trawl in inshore waters, *Fishery Technology*, 31(2): 118-122.
- Rao, S.V.S.R., Pillai, N.S., Boopendranath, M.R. and Abbas, M.S. (1994) Performance of a rope trawl in deep waters off Northwest coast of India, *Fishery Technology*, 31(2): 127-132.
- Ravi, R., Vipin, P.M., Boopendranath, M.R., Joshy, C.G. and Edwin, L. (2013) Structural changes in the mechanised fishing fleet, operating off Kerala, India, Paper presented in International Symposium on Greening Fisheries towards Green Technologies in Fisheries, 21-23 May 2013, organised by SOFT(I) and CIFT, Kochi.
- Ravindran, K. (1998) Trends in fishing craft development, In: Balachandran, K.K., Iyer, T.S.G., Madhavan, P., Joseph, J., Perigreen, P.A., Raghunath, M.R. and Varghese, M.D. (Eds.) *Advances and Priorities in Fisheries Technology*, Society of Fisheries Technologists (India), Cochin. p. 107-110.
- Rawitscher, M. A. (1978) *Energy Cost of Nutrients in the American Diet*. PhD Thesis, University of Connecticut, Storrs, Connecticut.
- Rawitscher, M. and Mayer, J. (1977) Nutritional outputs and energy inputs in seafood. *Science* 198: 261–264.
- Remesan, M.P. (2002) *Otter Boards and other Sheer Devices Winter School on Advances in Harvest Technology* 20 Nov. - 19 December, 2002.
- Remesan, M.P., Boopendranath, M.R. and Meenakumari, B. (2009) – Towards fleet optimization in the marine fisheries of India and prospects for

- modernization of fishing practices, Sagara Sangamam Souvenir, IFCOS, Thiruvananthapuram, 83-94 p.
- Reuters (2015) <http://in.reuters.com/article/india-fuel-reforms-idINSGE65209520100625> Accessed on 15 May 2015
- Rihan, D. (2010) Measures to reduce interactions of marine megafauna with fishing operations. In: He, P. (Ed.), Behavior of Marine Fishes: Capture Processes and Conservation Challenges. Blackwell Publishing, 315–342 p.
- Rihan, D., O'Regan, N. and Deakin, B. (2010) The Development of a “Green Trawler”, First International Symposium on Fishing Vessel Energy Efficiency E-Fishing, Vigo, Spain, May 2010.
- Rochereau, S. P. (1976) Energy analysis and coastal shelf resource management: Nuclear power generation vs. seafood protein production in the Northeast region of the U.S. Ph.D. Dissertation. Cornell University.
- Sala, A., Notti, E. and Buglioni, G. (2012) Audit Energetici nel settore della pesca eAudit, (Progetto FEP 02ACO201109), CNR-ISMAR, Ancona, Rapporto Finale Progetto e-Audit, 43p
- Salz, P. and Framian (2006) Economic Performance of Eu Fishing Fleets and Consequences of Fuel Price Increase, Contribution to the conference on Energy Efficiency in Fisheries Brussels, 11-12 May 2006, 11p.
- Samples, K.C. (1983) An economic appraisal of sail-assisted commercial fishing vessels in Hawaiian waters. Marine Fisheries Review, 45 (7–9): 50–55
- Sasikumar, P.K., Aegisson, G. and Mathew, P.M. (1992) Energy Conservation in Marine Fisheries-A Study on Attitudes and Knowledge, Energy Conservation

- Programme, Norwegian Marine Technology Research Institute, Trondheim, Norway and Institute of Small Enterprises and Development, Cochin: 25 p.
- Sato, K., Watanabe, H., Ishikawa, M. and Akizawa, H. (1989) Chronological change of energy input for squid angling in Japan 1956-1983. *Bulletin of the Japanese Society of Scientific Fisheries/Nippon Suisan Gakkaishi*, 55(11): 1941-1945.
- Sathianandan, T. V., Jayasankar, J., Vivekanandan, E., Narayankumar, R. and Pillai, N. G. K. (2008) Estimates on potential yield and maximum sustainable fleet size for marine fisheries in Kerala, *Journal of Marine Biological Association of India*, 50 (2): 196 – 201.
- Schau, E. M., Ellingsen, H., Endal, A. and Aanonsen, S. A. (2009) Energy consumption in the Norwegian fisheries, *Journal of Cleaner Production*, 17(3): 325–334.
- Schau, Erwin A. Meissner (2012) Environmental life cycle assessments of fish food products with emphasis on the fish catch process. Department of Industrial Economics and Technology Management. Trondheim, Norway, NTNU, Norwegian University of Science and Technology. Thesis for the degree of philosophiae doctor.
- Scott, W.G. (1981) Energy and Fish Harvesting: Conference Proceedings. Fisheries and Oceans Canada, Ottawa, 166 p.
- Seafish, IFREMER & DIFTA (1993) Otterboard performance and behaviour, Seafish Industry Authority, Hull, UK; IFEMER, Brest, France; and DIFTA, Hirtshals, Denmark: 138 p.
- Senthilathiban, R., Venkataramanujam, K., Selvaraj, P. and Sanjeeviraj, G. (1997) Costs and earnings of trawlers operating at Tuticorin, Tamilnadu. *Fishery Technology*, 34 (2): 31–34.

- Sevastanov (1989) Naval Architects' approach to energy preservation in fishing vessel design process and vessel exploitation, Paper 3.6, In: Proceedings of International Fisheries Energy Optimisation Working Group Meeting, 28-30 August, 1989, University of British Columbia, Vancouver, B.C., Canada.
- Sheshappa, D.S. (1993) Design of propulsion plants for energy efficient fishing vessels, In: Proceedings of the National Workshop on Low Energy Fishing, Fishery Technology, Special Issue, Society of Fisheries Technologists, Cochin. p. 86-90.
- Shibu, A.V. (1999) Comparative Efficiency of Different Types of Mechanised Fishing Operations along the Cochin Coast, Ph.D. Thesis, Cochin University of Science and Technology, Cochin: 217 p.
- SIK, (2001) International conference on lca in foods, Gothenburg, SIK, the Swedish Institute for Food and Biotechnology.
- SIK, (2007) Book of proceedings - The 5th International Conference - Lca in Foods, 25-26 April 2007. Gothenburg, Sweden, Swedish Institute for Food and Biotechnology (SIK).
- Silas, E.G. (1977) Indian fisheries: 1947-1977. Central Marine Fisheries Research Institute, Cochin.
- Silvenius, F. and Grönroos, J. (2004) Suomen kalatuotteiden elinkaariarviointi [Life Cycle Assessments of the typical finnish fish products for food - in finnish with english summary, tables and figures]. Helsinki, Finnish Environment Institute: 119.
- Sreedhar, U., Badonia, R. and Meenakumari, B. (2002) Modification in trawls for sustainable fishing off Gujarat coast Second Indian Fisheries Science Congress, CIAE, Bhopal , 23-25 October 2002.

- Sreekrishna, Y. and Shenoy, L. (2001) Fishing gear and craft technology. Indian Council of Agricultural Research. New Delhi, 342p.
- Sterling, D. and Goldsworthy, L. (2007) Energy Efficient Fishing: A 2006 review, Part A - Alternative fuels and efficient engines, Australian Government, Fisheries Research and Development Corporation, Project No. 2005/239. Final Report: Part A- May 2007.
- Sterling, D. and Kim, K. (2007) Energy Efficient Fishing: A 2006 review, Part B - Hull Characteristics and Efficiency, Australian Government, Fisheries Research and Development Corporation, Project No. 2005/239. Final Report: Part B- May 2007.
- Stratoudakis, Y., & Marcalo, A. (2002) Sardine slipping during purse seining off northern Portugal. *ICES Journal of Marine Science*, 59: 1256-1262.
- Sullivan, R. (2006) IIGCC 2006 conference report: Managing investment in a changing climate, Institutional Investors Group on Climate Change (IIGCC): 35.
- Sumaila, U.R., Teh, L., Watson, R., Tyedmers, P. and Pauly, D. (2008) Fuel price increase, subsidies, overcapacity and resource sustainability. *ICES Journal of Marine Science*, 65: 832–840.
- Sumaila, U., Khan, A., Dyck, A., Watson, R., Munro, G., Tydemers, P. and Pauly, D. (2010) A bottom-up re-estimation of global fisheries subsidies. *Journal of Bioeconomics*, 12: 201–225.
- Suuronen, P. Chopin, F., Glass, C., Løkkeborg, S., Matsushita, Y., Queirolo, D. and Rihan, D. (2012) Review Low impact and fuel efficient fishing— Looking beyond the horizon, *Fisheries Research* 119 - 120:135 – 146

- Svanes, E., Vold, M. and Hanssen, O.J. (2011) Environmental assessment of cod (*Gadus morhua*) from autoline fisheries. *The International Journal of Life Cycle Assessment* 16(7): 611-624.
- Tait, D. (1989a) The effect of knotless and knotted netting on the drag of demersal trawl, In: *Proceedings of the World Symposium on Fishing Gear and Fishing Vessel Design 1988*, Marine Institute, St. John's, Newfoundland, Canada. p. 119-131.
- Tait, D. (1989b) Gear monitoring and its role in efficiency, Paper 2.4, In: *Proceedings of International Fisheries Energy Optimisation Working Group Meeting, 28-30 August, 1989*, University of British Columbia, Vancouver, B.C., Canada.
- Tan, R.R. and Culaba, A.B. (2009) *Estimating the Carbon Footprint of Tuna Fisheries*; Center for Engineering and Sustainable Development Research De La Salle University, 2401 Taft Avenue, 1004 Manila, Philippines.
- TEFLES (2012) *Technologies and Scenarios For Low Emissions Shipping, REPORT / D2.1:State of the art and efficiency report*, Project Number: SCP0-GA-2010-266126, 184 p.
- The New Indian Express (2015) 'Imported' Fish Meet 1/3 of Kerala's Consumption <http://www.newindianexpress.com/states/kerala/Imported-Fish-Meet-13-of-Keralas-Consumption/2015/02/06/article2655025.ece>
Accessed on 01 November 2015.
- Thomas, S.N. (2009) Fishing floats and sinkers. In: *Handbook of Fishing Technology*, CIFT, Cochin, 237-248 p.
- Thrane, M. (2004a) *Environmental impacts from Danish fish products - Hot spots and environmental policies*, PhD dissertation, Department of Development and Planning, Aalborg University, Denmark, 510 p.

- Thrane, M. (2004b) Energy consumption in the Danish fishery. identification of key factors. *Journal of Industrial Ecology*, 8:223–239.
- Thrane, M. (2006) LCA of Danish Fish Products. New methods and insights. *The International Journal of Life Cycle Assessment*, 11 (1): 66–74.
- Torres, J.M., González, L., Spyarakos, E. and Rodríguez, L. (2010) Routing optimization using neural networks and oceanographic models from remote sensing data. *Proceedings of the First International Symposium on Fishing Vessel Energy Efficiency*, Vigo, Spain; 2010. May 18-20.
- Tyedmers, P. (2000) *Salmon and Sustainability: The Biophysical Cost of Producing Salmon Through the Commercial Salmon Fishery and the Intensive Salmon Culture Industry*. PhD Thesis, University of British Columbia, Vancouver, Canada.
- Tyedmers, P. (2001) Energy consumed by North Atlantic fisheries. In: *Fisheries' Impacts on North Atlantic Ecosystems: Catch, Effort and National/Regional Datasets*. Zeller, D., Watson, R. and Pauly, D. (eds.). Fisheries Centre, University of British Columbia, Vancouver, 12–34 p. <http://www.seaaroundus.org/report/method/tyedmers10.pdf>.
- Tyedmers, P. (2004) Fisheries and energy use. In: *Encyclopaedia of Energy*. Cleveland, C. (ed.). Elsevier, San Diego, vol. 2. 683–693 p.
- Tyedmers, P.H., Watson, R., and Pauly, D. (2005). Fueling Global Fishing Fleets. *Ambio*. 34 (8): 635-638.
- Tyedmers, P. and Parker, R.W.R. (2012) *Fuel Consumption and Greenhouse gas, Emissions from Global Tuna Fisheries: A preliminary assessment*. International Seafood Sustainability Foundation, results of a research project from School of Resource & Environmental Studies, Dalhousie University, Canada.

- United Nations (1998) Kyoto protocol to the united nations framework convention on climate change. Bonn, United Nations Framework Convention on Climate Change. Retrieved 5 May, 2009, from http://unfccc.int/kyoto_protocol/items/2830.php.
- United Nations (2008) Acting on climate change: The UN system delivering as one. New York: The United Nations.
- Valdemarsen, J.W. and Suuronen, P. (2003) Modifying fishing gear to achieve ecosystem objective, In: Sinclair, M. and Valdemarsen, G. (eds.) Responsible Fisheries in the Marine Ecosystems. FAO, Rome and CABI International Publishing. Wallingford, 321-341 p.
- Vázquez-Rowe, I., Iribarren, D., Hospido, A., Moreira, M.T. and Feijoo, G. (2010a) Linking fuel consumption and eco-efficiency in fishing vessels, A brief case study on selected Galician fisheries, First International Symposium on Fishing Vessel Energy Efficiency E-Fishing, Vigo, Spain, May 2010.
- Vázquez-Rowe, I., Moreira, M.T. and Feijoo, G. (2010b) Life cycle assessment of horse mackerel fisheries in Galicia (NW Spain). Comparative analysis of two major fishing methods. Fisheries Research, 106 (3): 517–527.
- Vázquez-Rowe, I., Iribarren, D., Moreira, M.T., Feijoo, G. (2010c) Combined application of Life Cycle Assessment and data envelopment analysis as a methodological approach for the assessment of fisheries. The International Journal of Life Cycle Assessment ,15(3):272–83.
- Vázquez-Rowe, I., Moreira, M. T. & Feijoo, G. (2011). Life cycle assessment of fresh hake fillets captured by the Galician fleet in the northern stock. Fisheries Research, 110: 128-135.

- Vázquez-Rowe, I., Moreira, M.T. and Feijoo, G. (2012a) Environmental assessment of frozen common octopus (*Octopus vulgaris*) captured by Spanish fishing vessels in the Mauritanian EEZ. *Marine Policy* 36 (1): 180–188.
- Vázquez-Rowe, I., Hospido, A., Moreira, M.T. and Feijoo, G. (2012b). Best practices in Life Cycle Assessment implementation in fisheries: improving and broadening environmental assessment for seafood production systems. *Trends in Food Science and Technology*, 28: 116-131.
- Vázquez-Rowe, I., Villanueva-Rey, P., Moreira, M.T. and Feijoo, G. (2014) A review of energy use and greenhouse gas emissions from Worldwide hake fishing. In: *Assessment of Carbon Footprint in Different Industrial Sectors*, (Ed: Muthu, S.S.), Volume 2, Springer: 1-29.
- Veal, D., M. V. Rawson Jr, and W. Hosking (1982) Structure, Strategy and Fuel Consumption in the Gulf Shrimp Fleet. *Fishing Industry Energy Conservation Conference*, The Society of Naval Architects and Marine Engineers, New York, 43-54 p.
- Veenstra, F.A. (1986) Application of Energy Saving Concepts in Dutch Cutter Design and Operation, *ICES-CM 1986/B:20*: 25 p.
- Vivekanandan, E. (2003) *Marine fisheries and fish biodiversity in India*. CMFRI (Madras Research Centre).
- Vivekanandan, E., Singh, V. V. and Kizhakudan, J. K. (2013) Carbon footprint by marine fishing boats of India. *Current Science*, 105(3): 361–366.
- Vivekanandan, E., Srinath, M. and Kuriakose, S. (2005) Fishing the marine food web along the Indian coast. *Fisheries Research*, 72: 241-252.
- Vivekanandan, V. (1993) Kerala fisheries - growing energy inefficiency, In: *Proceedings of the National Workshop on Low Energy Fishing*, Fishery

- Technology, Special Issue, Society of Fisheries Technologists, Cochin, India, p. 281-286.
- Vold, M and Svanes, E (2009) LCA as environmental improvement tool for products from line caught cod. In: Nemecek, T and Gaillard, G (Eds.), Proceedings of the 6th international conference on lca in the agri-food sector – towards a sustainable management of the food chain. November 12–14, 2008, Zurich, Switzerland, Agroscope Reckenholz-Tänikon Research Station ART, 263-270 p.
- Walsh, S.J. (2010) Emission Profile of a Keystone Fishery and Recommendations for Fuel Management - A Case Study on the Isle of Man Scallop Fishery, Non-Technical Summary, Report to DEFA, School of Environmental Sciences, University of East Anglia, University Plain, Norwich, NR4 7TJ.
- Ward, N., Montgomerie, M. and Lart, W. (2005) Fuel efficiency trials using Jackson trawls with reduced twine diameter on MFV Challenge II Seafish Report No. SR578, p.31.
- Warren, F.J. (2004) Climate change impacts and adaptation : A canadian perspective. Ottawa, Climate Change Impacts and Adaptation Program.
- Watanabe, H. and Okubo, M. (1989). Energy input in marine fisheries of Japan. Bulletin of the Japanese Society of Scientific Fisheries, 53: 1525-1531.
- Watanabe, H. and Uchida, J. (1984) An estimation of direct and indirect energy input in catching fish for fish paste products. Bulletin of the Japanese Society for the Science of Fish./Nippon Suisan Gakkaishi 50: 417–423.
- Watanabe, K. and Tahara, K. (2008). Evaluation of environmental performance for salmon by life cycle assessment. The Eighth International Conference on EcoBalance - The challenge of creating

- social and technological innovation through system-thinking, Tokyo, Dec 10-12, 2008, The Institute of Life Cycle Assessment.
- Watson, R. and Pauly, D. (2001) Systematic distortions in world fisheries catch trends. *Nature* 414: 534–536.
- Wileman, D.A. (1984) Project Oilfish: Investigation of the Resistance of Trawl. The Danish Institute of Fisheries Technology, The North Sea Centre, Hirtshals, Denmark: 123 p.
- Wilson, J.D.K. (1999) Fuel and Financial Savings for Operators of Small Fishing Vessels. FAO Fisheries Technical Paper 383, FAO, Rome, 46 p.
- Winther, U., Ziegler, F., Skontorp Hognes, E., Emanuelsson, A., Sund, V. and Ellingsen, H. (2009) Carbon footprint and energy use of Norwegian seafood products. SINTEF Report Nr. SHF80 A096068, 91 p.
- Wiviott, D.J. and Mathews, S.B. (1975) Energy efficiency comparison between the Washington and Japanese otter trawl fisheries of the northeast Pacific. *Marine Fisheries Review*, 37 (4): 21–24.
- World Bank and FAO (2009) The Sunken Billions: The Economic Justification for Fisheries Reform. Agriculture and Rural Development Department, The World Bank. Washington, DC, 100 p.
- Worm, B., Barbier, E.B., Beaumont, N., Duffy, J.E., Folke, C., Halpern, B.S., Jackson, J.B.C., Lotze, H.K., Micheli, F., Palumbi, S.R., Sala, E., Selkoe, K.A., Stachowicz, J.J. and Watson, R. (2006) Impacts of biodiversity loss on ocean ecosystem services. *Science*, 314: 787-760.
- Worm, B., Hilborn, R., Baum, J.K., Branch, T.A., Collie, J.S., Costello, C., Fogarty, M.J., Fulton, E.A., Hutchings, J.A., Jennings, S., Jensen, O.P., Lotze, H.K., Mace, P.A., McClanahan, T.R., Minto, C., Palumbi, S.R.,

- Parma, A.M., Ricard, D., Rosenberg, A.A., Watson, R. and Zeller, D. (2009) Rebuilding global fisheries. *Science*, 325: 578-585.
- Yergin, D. (2011) “The Quest. Energy security, and the remaking of the modern world.” The Penguin Press. New York. ISBN 978-1-59420-283-4. 804 p.
- Ziegler, F. and Hansson, P.A. (2003). Emissions from fuel combustion in Swedish cod fishery. *Journal of Cleaner Production*. 11: 303–314.
- Ziegler, F., Nilsson, P., Mattsson, B. and Walther, Y. (2003) Life cycle assessment of frozen cod fillets including fishery-specific environmental impacts. *The International Journal of Life Cycle Assessment*, 8(1):39–47.
- Ziegler, F. and Valentinsson, D. (2008) Environmental life cycle assessment of Norway lobster (*Nephrops norvegicus*) caught along the Swedish west coast by creels and conventional trawls—LCA methodology with case study. *The International Journal of Life Cycle Assessment*, 13 (6): 487–497.
- Ziegler, F., Eichelsheim, J., Emanuelsson, A., Flysjö, A., Ndiaye, V. and Thrane, M. (2009) Life cycle assessment of southern pink shrimp products from Senegal - an environmental comparison between artisanal fisheries in the Casamance region and a trawl fishery based in dakar. Göteborg, SIK.

.....**SCS**.....

PUBLICATIONS

Research Paper

Ravi, R., Vipin, P.M., Boopendranath, M.R., Joshy C.G. and Edwin, L. (2014) Structural changes in the mechanized fishing fleet of Kerala, South India. *Indian Journal of Fisheries* 61(2): 1-6 (NAAS Score: 6.20).

Books

Edwin, L., Pravin, P., Madhu, V.R., Thomas, S.N., Remesan, M.P., Baiju M.V., **Ravi, R.**, Das, D.P.H., Boopendranath, M.R. and Meenakumari, B. (2014) *Mechanised Marine Fishing Systems: India*, Central Institute of Fisheries Technology, Kochi: 277 p. (ISBN: 978-81-924362-8-9).

Edwin, L., Thomas, S.N., Pravin, P., Remesan, M.P., Madhu, V.R., Baiju M.V., Sreejith P.T., **Ravi, R.** and Das, D.P.H. (2014) *CIFT Fishing Systems Catalogue 1- Mechanised Marine Fishing Systems: Kerala*, Central Institute of Fisheries Technology, Kochi: 113 p. (ISBN: 978-81-924362-7-2).



Structural changes in the mechanised fishing fleet of Kerala, South India

RENJU RAVI, P. M. VIPIN, M. R. BOOPENDRANATH, C. G. JOSHY AND LEELA EDWIN

Central Institute of Fisheries Technology, Matsyapuri, Kochi - 682 029, Kerala, India

e-mail: renjuraviif@yahoo.com

ABSTRACT

Kerala State situated in the south-west coast of India, has traditionally been the foremost fishery area of the Indian sub-continent. With increasing fishing pressure in the coastal waters, fishermen operating in mechanised sector were forced to venture in to deeper waters in search of newer fishing grounds in order to maintain their catches. Marine fisheries have undergone significant changes since the 1950s and the changes in number and capacities of fishing vessels have been more significant in the last decade. In this paper, an attempt has been made to compare the structural changes in terms of length overall (L_{OA}) and installed engine horsepower among three commercially important fishing practices viz., trawling, purse seining and gillnetting in Kerala, over the last decade. The results have shown large scale changes in the structure of the fishing fleet in terms of size and installed engine horsepower among trawlers, purse seiners and gillnetters operating off Kerala. The study indicated an exponential growth in engine horsepower among trawlers above 18 m in L_{OA} , in recent years. This paper also points out the need for regulating capacities of the fishing vessel in order to conserve fuel and reduce greenhouse gas (GHG) emissions.

Keywords: Engine horsepower, Gillnetter, Kerala, Length overall, Purse seiner, Trawler

Introduction

In India, fisheries is an important sector which plays a significant role in creating job opportunities, enhancing income as well as foreign exchange earnings and availability of protein rich food. India was ranked fifth in the world capture fishery production, during 2011 (FAO, 2013). The annual potential yield from the Exclusive Economic Zone (EEZ) of India has been re-validated at 4.42 million t, of which 3.84 million t is from the zone up to 100 m depth and 0.58 million t is from deeper waters (GOI, 2011). The present catch of 3.82 million t (2011) (CMFRI, 2013) forms 86.45% of the re-validated fishery potential and is largely derived from the intensively fished coastal zone.

Kerala State, situated in the south-west coast of India, has traditionally been the foremost fishery area of the Indian sub-continent (CMFRI, 2013). It has a coastline of 590 km and a continental shelf area of 39,139 sq km. Kerala ranked first in marine fish production among the maritime states of India, contributing about 19% of the total marine landings (0.74 million t) during 2011 (CMFRI, 2013). Marine fishing fleet in Kerala consists of 4,722 (21.7%) mechanised, 11,175 (51.3%) motorised and 5,884 (27.0%) non-motorised fishing vessels (CMFRI, 2012). The marine

landings are mainly contributed by the mechanised (56%) and motorised (42%) sectors (Mohamed *et al.*, 2013). With increasing fishing pressure in the coastal waters, fishermen operating in the mechanised sector are forced to go to deeper waters in search of newer fishing grounds in order to maintain their catches. Marine capture fisheries in Kerala, have gone through significant changes since 1950s and the changes in number and capacities of fishing vessels have been more pronounced in the last decade. Excess fleet capacity and increased fuel consumption by the mechanised fisheries have been worsening over the years. In this paper, an attempt has been made to compare the structural changes in terms of length overall (L_{OA}) and installed engine horsepower among three commercially important fishing practices, viz., trawling, purse seining and gillnetting in the marine fisheries sector of Kerala, over the last decade.

Materials and methods

Data on length overall and engine horsepower of mechanised fishing vessels, viz., trawlers, purse seiners and gillnetters operating in Kerala were sourced from Fishing Vessel Registration Database of the Marine Products Export Development Authority (MPEDA). Data pertaining to 637 trawlers forming 17% of the total trawlers,

27 purse seiners forming 45% of the total purse seiners and 18 gillnetters comprising 4% of the total gillnetters in the state, registered during 2008-2012, were taken for the present analysis. Additional information regarding mechanised fishing vessels and engines were collected from fishermen, dealers of marine engines, and boatyard operators using structured questionnaires. Details of vessel characteristics and horsepower in vogue during the last decade were obtained from Boopendranath (2000). The data were analysed using standard statistical procedures (*viz.*, frequency analysis and exponential modelling) using SAS 9.3, in order to ascertain the decadal changes that have taken place in terms of vessel size and horsepower, in the mechanised fisheries sector of Kerala.

Results and discussion

The growth pattern of mechanised fishing fleet in Kerala, during 1980-2010 period, is given in Fig. 1. The number of mechanised vessels increased from 983 in 1980, to 5088 in 1998, 5504 in 2005 and decreased to 4722 in 2010 (Anon 1981; CMFRI, 2006; DOF 2007; CMFRI, 2012). Trawlers constituted 76% of the mechanised fleet of Kerala in 1980, 88% in 1998 and 72% in 2005. In 2010, trawlers constituted about 77.9% of the total mechanised fleet of Kerala, followed by purse seiners and mechanised ring seiners (11.8%), gillnetters (9.7%) and liners (0.6%) (CMFRI, 2012). There were about 8 mechanised vessels per kilometre of coastline in Kerala during 2010.

Trawlers

About 4,722 trawlers are operating from Kerala (CMFRI, 2012) and the fleet consists of small, medium and large trawlers (Kurup *et al.*, 2009). Trawling is the most demanding fishing method in terms of energy consumption when compared to gillnetting, longlining,

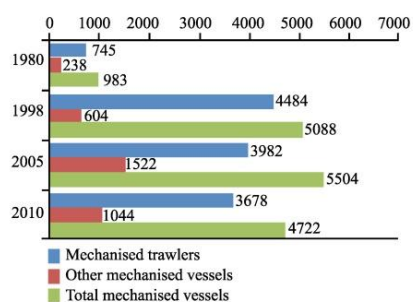

Fig. 1. Increase in number of mechanised trawlers, other mechanised vessels and total marine fishing fleet in Kerala during 1980-2010 (Source: Anon 1981; CMFRI, 2006; DOF 2007; CMFRI, 2012)

ring seining and purse seining (Gulbrandsen, 1986; Aegisson and Endal, 1993; Boopendranath, 2009).

Frequency distribution of length class of trawlers

A comparison of frequency distribution of length classes of trawlers operating from Kerala is shown in Fig. 2. During the year 2000, almost 56% of trawlers were of length class 13-14 m L_{OA} , followed by 12-13 m (12.3%), 11-12 m (9.1%), 14-15 m (8.4%), 10-11 m (5.8%), 15-16 m (4.6%) and 9-10 m (3.9%). During 2012, the most dominant length class (40.6%) was 19-20 m L_{OA} , followed by 20-21 m (15.9%), 18-19 m (10.7%), 17-18 m (6.1%), 21-22 m (5.2%) and representation by other length classes were below 4%. During 2012, length classes ranged from 9-10 m to 22-23 m L_{OA} , whereas during 2000, the range extended from 9-10 m to 15-16 m L_{OA} , showing a significant shift in the preferred size of trawlers.

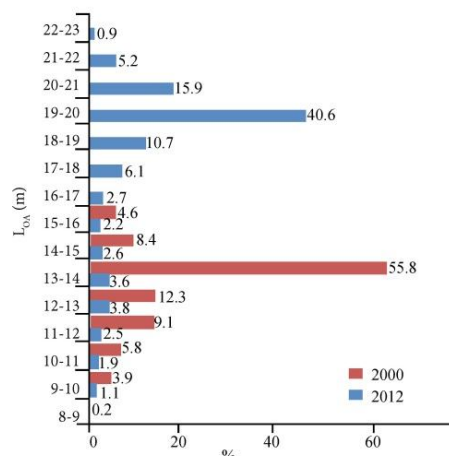

Fig. 2. Frequency distribution of length classes of trawlers in Kerala

Frequency distribution of installed engine horsepower of trawlers

Frequency distribution of engine horsepower (hp) of trawlers, during 2000 and 2012 are represented in Fig. 3. The engine horsepower in trawlers, during the year 2000, ranged between 50 and 150 hp, whereas in 2012, engine horsepower extended up to 495 hp. Engines with 100-150 hp were widely used (62.3%) during 2000, followed by engines with 50-100 hp (37.5%). During 2012, 24.7% of the trawlers were using engines with 100-150 hp, 18% with 150-200 hp, 16.8% with 300-350 hp and 16.2% with 250-300 hp. Trawlers with engines higher than 350 hp were 13.7% and those using less than 100 hp were 5.3%. Use of high horsepower

engines in trawlers coincided with the adoption of high speed trawling using fish trawls with large trawl mouth and having large meshes in the front trawl panel sections, for harvesting fast moving fishes.

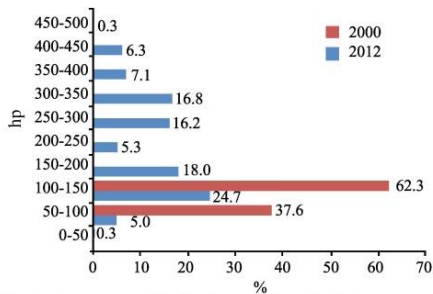

Fig. 3. Frequency distribution of installed horsepower of trawlers in Kerala

Relationship between length and engine horsepower of trawlers

The relationship between length and engine horsepower of trawlers during the year 2012 is shown in fig. 4. The scatter plot of overall length vs. engine horsepower of trawlers exhibited an exponential relation. The simple exponential function of the form Engine horsepower = $a \cdot \exp(b \cdot \text{length})$ was fitted by Levenberg marquardt algorithm using SAS 9.3. The resultant model is given by the equation:

$$\text{Engine horsepower} = 14.625 \cdot \exp^{0.147 \cdot \text{LOA}}; R^2 = 0.602$$

Fig. 4. explains the relationship between engine horsepower and length overall, with moderate R^2 value in terms of observed and predicted value. The rate of change of engine horsepower (hp) was 0.147 with respect to change in the L_{OA} . The exponential growth of engine horsepower was evident in trawlers with L_{OA} greater than 18 m.

Frequency distribution of makes of engines installed in trawlers

Fig. 5 depicts the frequency distribution of different makes of engines installed in trawlers operating from Kerala, during 2012. Marine diesel engines from 13 different manufacturers were prevalent. Ashok Leyland (India) marine diesel engines were most popular (57.3%), followed by Sinotruk (China) (15.9%), Weichai Power (China) (14.8%), Cummins (USA) (3.5%), Yuchai (China) (2.8%) and Caterpillar (USA) (1.4%). Representation of Ruston (England), Greaves (India), Wandi (China), MWM (Brazil), Hino (Japan) and Tata Cummins (India-USA) were 0.5% or less. Ashok Leyland (India) collaborates with Weichai Power (China) in marketing marine diesel engines in India.

Purse seiners

Purse seining is an active fishing method for harvesting of shoaling fishes and propulsion is required for reaching and returning from fishing ground and for operation of the gear. About 60 purse seiners operated from Kerala (CMFRI, 2012).

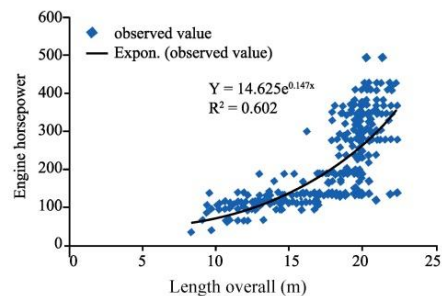

Fig. 4. Relationship between length and engine horsepower of trawlers during 2012

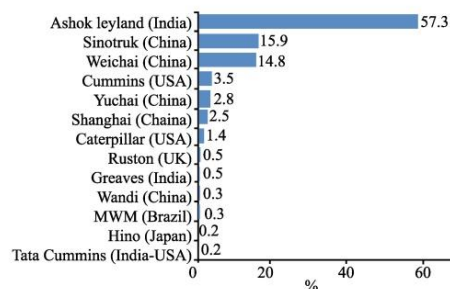

Fig. 5. Frequency distribution of different makes of engines installed in trawlers operating from Kerala, during 2012

Frequency distribution of length classes of purse seiners

A comparison of frequency distribution of length classes of purse seiners of Kerala is given in Fig. 6. During the year 2000, the dominant length class of purse seiners was 15-16 m L_{OA} (21.2%), followed by 14-15 m and 13-14 m (19.7% each), 12-13 m and 16-17 m (13.6% each), 17-18 m (10.6%) and 18-19 m (1.5%). Significant increase in the sizes of purse seiners were observed during 2012. Dominant length class during 2012 was 19-20 m L_{OA} (37%), followed by 18-19 m (25.9%), 17-18 m (14.8%) and 20-21 m (7.4%). Representation of length classes exceeding 21 m and less than 17 m were 3.7% each. During 2012, length classes of purse seiners ranged up to 21-22 m, while, during 2000, the range was only up to 18-19 m L_{OA} .

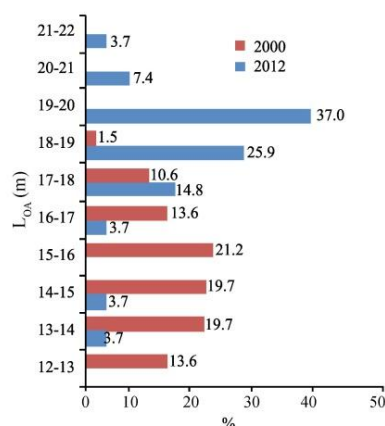

Fig. 6. Frequency distribution of length classes of purse seiners in Kerala

Frequency distribution of installed engine horsepower of purse seiners

Comparison of frequency distribution of installed engine horsepower among purse seiners of Kerala is shown in Fig. 7. During 2000, majority of the purse seiners (55.3%) had engines with 100-150 hp (55.3%), followed by 150-200 hp (44.7%). In 2012, engines with horsepower in the range of 150-200 gained dominance (37.0%), followed 100-150 hp (25.9%), 250-300 hp (22.2%), 300-350 hp (7.4%), 200-250 hp and 350-400 hp (3.7% each). The upward trend in the engine horsepower, coincided with increase in size of the purse seines deployed.

Gillnetters

Gillnetting is a passive method and propulsion is used for reaching the fishing ground, deployment of the gear and return to the base. About 460 gillnetters are operating from Kerala (CMFRI, 2012).

Frequency distribution of length classes of gillnetters

Frequency distribution of length classes of gillnetters in Kerala (Fig. 8) shows that, during the year 2000, gillnetters of length class 9-10 m L_{OA} (53%) dominated in the fleet, followed by 10-11 m (31.3%), 7-8 m (7.5%), 8-9 m and 12-13 m (3.8% each), 11-12 and 13-14 m (1.3% each). During 2012, the length classes 10-11 m, 14-15 m, 16-17 m and 17-18 m were the dominant classes (16.7% each), followed by 12-13 m (11.1%); 18-19 m and 19-20 m (5.5% each). During this period there was a conspicuous increase in the size of the gillnetters compared to the previous years.

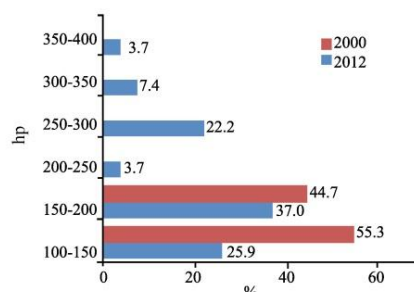

Fig. 7. Frequency distribution of installed horsepower of purse seiners in Kerala

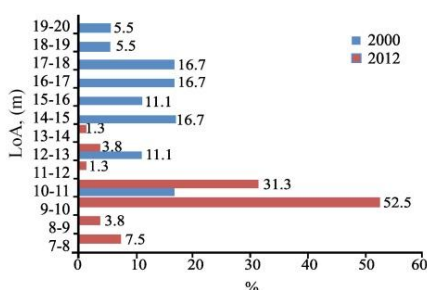

Fig. 8. Frequency distribution of length classes of gillnetters in Kerala

Frequency distribution of installed engine horsepower of gillnetters

Comparison of distribution of installed engine horsepower among gillnetters of Kerala, during 2000 and 2012 (Fig. 9) indicates that marine diesel engines with horsepower of 60-80 hp (52.3%) dominated the fleet during 2000, followed by engines with less than 60 hp (36.4%) and 80-100 hp (11.4%). There was a significant increase in the engine horsepower during 2012 with lower representation of 60-80 hp (5.6%) and 80-100 hp (16.7%) and higher representation of 100-120 hp (33.3%) and 120-140 hp engines (44.4%) in the fleet.

A decade ago, fishing vessels in Kerala were largely dependent on marine diesel engines of Indian origin with horsepower rating up to 193 hp, for powering the mechanised vessels (Boopendranath, 2000). During the last 4-5 years, there is an increasing tendency among the operators of trawlers, purse seiners and mechanised ring seiners to install high horsepower engines (Baiju *et al.*, 2012; Mohamed *et al.*, 2013). Majority of high horsepower engines used in mechanised vessels of Kerala include Chinese makes such as Sinotruk, Weichai Power,

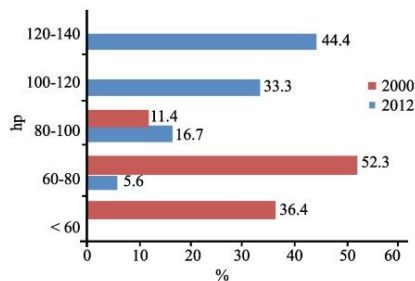

Fig. 9. Frequency distribution of installed engine horsepower of gillnetters in Kerala

Yuchai and Shanghai and high horsepower engines from Ashok Leyland in collaboration with Weichai Power.

Optimum fleet size of mechanised vessels for marine fishing off Kerala were estimated at 3030 and 3143, respectively by Kurup and Devaraj (2000) and Sathianandan *et al.* (2008). According to these estimates, the existing number of mechanised vessels in Kerala (CMFRI, 2012) are in excess by 50-55% than optimum fleet size. A recent estimate based on revalidated potential yield of fishery resources in the Indian Exclusive Economic Zone has given optimum mechanised fleet size as 4032 for Kerala, consisting of 3610 trawlers, 316 purse seiners and mechanised ring seiners and 72 gillnetters (Mohamed *et al.*, 2013). According to this estimate, the existing number of mechanised vessels in Kerala (CMFRI, 2012) are in excess by about 17% than required fleet size.

Though the number of mechanised fishing vessels in Kerala has shown a decrease by 14% between 2005 and 2010 census periods (CMFRI, 2006; 2012), fishing power of a considerable percentage of individual fishing units has significantly increased due to increase in installed engine horsepower, vessel capacities, improved navigation, fish detection capabilities and improved efficiency of fishing gear systems, in recent years, as evident from the present study as well as other studies (Boopendranath, 2009; Kurup *et al.*, 2009; Pillai *et al.*, 2009; Baiju *et al.*, 2012; Mohamed *et al.*, 2013). The results of the present study points to the need for optimising and regulating capacities of the fishing vessels based on their area/depth of operation, in order to mitigate negative impacts on resources, conserve fuel and reduce greenhouse gas (GHG) emissions, which has been highlighted in several studies (Bhathal and Pauly, 2008; Boopendranath, 2009; 2012; Kurup *et al.*, 2009; Baiju *et al.*, 2012; Mohamed *et al.*, 2013).

The results have demonstrated large scale changes in the structure of the mechanised fishing fleet of Kerala,

both in terms of size and installed engine horsepower among trawlers, purse seiners and gillnetters, during the last decade. The study indicated an exponential increase in engine horsepower, in recent years, among trawlers above 18 m in L_{OA} . With increasing fishing pressure in coastal waters and diminishing returns, the area of operation of mechanised fleet has further extended to deeper waters and vessels with larger size, power and capacities equipped for multiday fishing have become popular. The study also suggests the need to account for the increase in the fishing capacity of the vessels while planning for fishing fleet restrictions.

Acknowledgements

Authors are thankful to the Director, Central Institute of Fisheries Technology, for granting permission to publish this paper; to Chairman, Marine Products Development Authority, Cochin, for providing details of fishing vessels from Fishing Vessel Registration Database; and mechanised fishing vessel operators, dealers of marine diesel engines and boatyard operators of Kerala for their cooperation and assistance during the course of collection of materials for this study.

References

- Aegisson, G. and Endal, A. 1993. Energy conservation programme in Indian fisheries - Report from the Preparatory Phase, Report No. 402009.00.01.93, MARINTEK, Norwegian Marine Technology Research Institute, Trondheim, Norway, 45 pp.
- Anon. 1981. All India census of marine fishermen, craft and gear: 1980. *Mar. Fish. Infor. Serv. T and E. Ser.*, 30: 1-32.
- Baiju, M. V., Boopendranath, M. R. and Leela Edwin 2012. Need for regulating horsepower race in small-scale mechanised fishing vessels. *Fisheries Policy Update 8*, Central Institute of Fisheries Technology, Cochin, 6 pp.
- Bhathal, B. and Pauly, D. 2008. Fishing down marine food webs and spatial expansion of coastal fisheries in India, 1950-2000. *Fish. Res.*, 91: 26-34.
- Boopendranath, M. R. 2000. *Studies on energy requirement and conservation of selected fish harvesting systems*. Ph. D. Thesis. Cochin University of Science and Technology, Cochin, India, 273 pp.
- Boopendranath, M. R. 2009. Responsible fishing operations. In: Meenakumari, B., Boopendranath, M. R., Pravin, P., Thomas, S. N. and Edwin, L. (Eds.). *Handbook of fishing technology*. Central Institute of Fisheries Technology, Cochin, p. 259-295.

Renju Ravi *et al.*

6

- Boopendranath, M. R. 2012. Waste minimisation in fishing operations, *Fish. Technol.*, 49(2): 109-119.
- CMFRI 2006. *Marine fisheries census 2005 Part-1*, Central Marine Fisheries Research Institute, Cochin, 97 pp.
- CMFRI 2012. *Marine fisheries census 2010 Part-1 India*, Department of Animal Husbandry, Dairying and Fisheries and Central Marine Fisheries Research Institute, Cochin, 98 pp.
- CMFRI 2013. Estimated marine fish landings in India. <http://www.cmfri.org.in/annual-data.html> (Accessed on 1 June 2013).
- DOF 2007. Report of the Expert Committee for impact assessment of ban on bottom trawling imposed along Kerala coast. Directorate of Fisheries, Government of Kerala, Thiruvananthapuram, ix+292 pp.
- FAO 2013. *Global capture fisheries production statistics 2011*. <ftp://ftp.fao.org/fi/newsGlobalCaptureProductionStatistics2011.pdf> (Accessed on 1 June 2013), 4 pp.
- GOI 2011. *Report of the Working Group on development and management of fisheries and aquaculture, for the XII Five Year Plan (2012-17)*. Planning Commission, Government of India, New Delhi, 147 pp.
- Gulbrandsen, O. 1986. *Reducing fuel cost of small fishing boats*. BOBP/WP/27, Bay of Bengal Programme, Madras, 15 pp.
- Kurup, B. M., Purushan, K. S., Pillai, N. G. K., Boopendranath, M. R., Lathy, K. M., Mony, P. R., Saira Banu, Sahadevan, P., Anithakumari, D. and Sandhia, R. 2009. *Report of the expert committee for the registration of fishing vessels*, Directorate of Fisheries, Govt. of Kerala, Thiruvananthapuram, xi+189 pp.
- Kurup, K. N. and Devaraj, N. 2000. Estimates of optimum fleet size for the exploited Indian shelf fisheries. *Mar. Fish. Infor. Serv. T. and E. Ser.*, 165: 2-11
- Mohamed, K. S., Puthra, P., Sathianandan, T. V., Baiju, M. V., Sairabanu, K. A., Lethy, K. M., Sahadevan, P., Chandrasekharan Nair, Lailabeevi, M. and Sivaprasad, P. S. 2013. *Report of the committee to evaluate fish wealth and impact of trawl ban along Kerala coast*. Department of Fisheries, Government of Kerala, 68 pp.
- Pillai, N. G. K., Vivekanandan, E., Ganga, U. and Ramachandran, C. 2009. Marine fisheries policy brief 1: Kerala. *CMFRI Special Publication*, 100 : 1-24.
- Sathianandan, T. V., Jayasankar, J., Vivekanandan, E., Narayankumar, R. and Pillai, N. G. K. 2008. Estimates on potential yield and maximum sustainable fleet size for marine fisheries in Kerala. *J. Mar. Biol. Ass. India*, 50(2): 196-201.

MECHANISED MARINE FISHING SYSTEMS: INDIA



**National Fund for Basic, Strategic &
Frontier Application Research in Agriculture**
(Indian Council of Agricultural Research)
New Delhi



CENTRAL INSTITUTE OF FISHERIES TECHNOLOGY
(Indian Council of Agricultural Research)
Matsyapuri, P.O., Cochin - 682 029

Mechanised Marine Fishing Systems: India

Leela Edwin, P. Pravin, V.R. Madhu, Saly N. Thomas,
M.P. Remesan, M.V. Baiju, Renju Ravi, P.H. Dhiju Das,
M.R. Boopendranath, B. Meenakumari



Central Institute of Fisheries Technology
CIFT Junction, P.O., Matsyapuri
Kochi – 682 029, India



2014

Mechanised Marine Fishing Systems: India

©2014 Central Institute of Fisheries Technology, Kochi, India

All rights reserved. No part of this publication may be reproduced in any form or by any means, without the prior written permission of the publishers.

Central Institute of Fisheries Technology
CIFT Junction, P.O. Matsyapuri, Kochi - 682 029, India
Phone : 91 (0)484-2412300 E-mail : cift@ciftmail.org
Fax : 91 (0)484-2668212 aris.cift@gmail.com

ISBN : 978-81-924362-8-9

Published by : Dr. T.K. Srinivasa Gopal, Director, Central Institute of Fisheries Technology, Kochi

Citation : Edwin, L., Pravin, P., Madhu, V.R., Thomas, S.N., Remesan, M.P., Baiju, M.V., Ravi, R., Das, D.P.H., Boopendranath, M.R. and Meenakumari, B. (2014) Mechanised Marine Fishing Systems: India, Central Institute of Fisheries Technology, Kochi: 277 p.

Printers : PrintExPress, Kaloor, Kochi - 682 018

Cover design : Pradip Kumar Mahato, CIFT, Kochi



CIFT Fishing Systems Catalogue 1

Mechanised Marine Fishing Systems: Kerala

Leela Edwin, Saly N. Thomas, P. Pravin, M. P. Remesan, V. R. Madhu,
M. V. Baiju, P. T. Sreejith, Renju Ravi, P. H. Dhiju Das



Central Institute of Fisheries Technology
CIFT Junction, P.O., Matsyapuri
Kochi – 682 029, India



2014

CIFT Fishing Systems Catalogue 1

Mechanised Marine Fishing Systems: Kerala

©2014 Central Institute of Fisheries Technology, Kochi, India

All rights reserved. No part of this publication may be reproduced in any form or by any means, without the prior written permission of the publisher.

Central Institute of Fisheries Technology
CIFT Junction, P.O. Matsyapuri, Kochi - 682 029, India
Phone : 91 (0)484-2412300 E-mail : cift@ciftmail.org
Fax : 91 (0)484-2668212 aris.cift@gmail.com

ISBN : 978-81-924362-7-2

Published by : Dr. T.K. Srinivasa Gopal, Director, Central Institute of Fisheries Technology, Kochi

Citation : Edwin, L., Thomas, S.N., Pravin, P., Remesan, M.P., Madhu, V.R., Baiju, M.V., Sreejith, P.T., Ravi, R. and Das, D.P.H. (2014) *CIFT Fishing Systems Catalogue 1- Mechanised Marine Fishing Systems: Kerala*, Central Institute of Fisheries Technology, Kochi: 113 p.

Printers : PrintExPress, Kaloor, Kochi - 682 018

Cover design : Pradip Kumar Mahato, CIFT, Kochi



School of Industrial Fisheries
Cochin University of Science and Technology
Kochi- 682022