

T493



**NOVEL APPLICATIONS OF CASHEW NUT  
SHELL LIQUID IN THE POLYMER FIELD**

*Thesis submitted to the*  
**COCHIN UNIVERSITY OF SCIENCE AND TECHNOLOGY**

*in partial fulfilment of the requirements  
for the award of the degree of*  
**DOCTOR OF PHILOSOPHY**  
*under the*  
**FACULTY OF TECHNOLOGY**

*by*  
**MARY LUBI C.**

**DEPARTMENT OF POLYMER SCIENCE AND RUBBER TECHNOLOGY  
COCHIN UNIVERSITY OF SCIENCE AND TECHNOLOGY**

**Kochi-682022, INDIA**

**January 2007**

**Department of Polymer Science and Rubber Technology  
Cochin University of Science and Technology  
Kochi- 682022, India**

**Dr. Eby Thomas Thackil**  
B.Sc. Eng, MTech, Ph.D  
Reader

Phone: 0484 2575723 (Off)  
0484 2331426 (Res)  
E-Mail: ethackil@cusat.ac.in

**Date: 30<sup>th</sup> January 2007**

**CERTIFICATE**

*This is to certify that the thesis entitled " Novel applications of cashew nut shell liquid in the polymer field " which is being submitted by Mary Lubi C., in partial fulfilment of the requirements for the award of the degree of Doctor of Philosophy, to the Cochin University of Science and Technology, Kochi-22 is a record of the bonafide research work carried out by her under my guidance and supervision, in the Department of Polymer Science and Rubber Technology, Cochin-682 022, and no part of the work reported in the thesis has been presented for the award of any degree from any other institution.*



**Dr. Eby Thomas Thackil**  
Supervising Teacher

## DECLARATION

*I hereby declare that the work presented in this thesis entitled “Novel applications of cashew nut shell liquid in the polymer field” is based on the original research work carried out by me under the guidance and supervision of Dr. Eby Thomas Thachil, Reader, Department of Polymer Science and Rubber Technology, Cochin University of Science and Technology, Cochin- 682 022 and no part of the work reported in this thesis has been presented for the award of any degree from any other institution.*

Kochi-22

30<sup>th</sup> January 2007



**Mary Lubi C.**

# CONTENTS

**Preface**

**Abstract**

|                  |   |            |
|------------------|---|------------|
| <b>CHAPTER 1</b> | <b>Introduction and literature survey</b>                                 | <b>1</b>   |
| <b>CHAPTER 2</b> | <b>Synthesis of CNSL resins.</b>  | <b>59</b>  |
| <b>CHAPTER 3</b> | <b>Development of CNSL based adhesives</b>                                | <b>79</b>  |
| <b>CHAPTER 4</b> | <b>Ageing studies on rubbers modified by<br/>CNSI- phenol- hexa resin</b> | <b>113</b> |
| <b>CHAPTER 5</b> | <b>Development of particleboard</b>                                       | <b>185</b> |
| <b>CHAPTER 6</b> | <b>Conclusions</b>  | <b>229</b> |
|                  | <b>List of abbreviations and symbols</b>                                  | <b>231</b> |
|                  | <b>List of publications</b>   | <b>235</b> |

**\* Detailed contents are given at the beginning of each chapter**



## PREFACE

Cashew nut shell liquid (CNSL) occurs in the soft honeycomb of the shell of the cashew nut. It is a byproduct of the cashew nut processing industry. CNSL contains mainly four components: cardanol, cardol, anacardic acid and 2-methyl cardol. Components of CNSL are phenolic in nature. It is a feasible natural alternative to petrochemically derived phenol.

The thesis consists of six chapters. First chapter consists of introduction and literature review. Synthesis of CNSL- hexa resin, characterization of the synthesised resin and the effect of P: F ratio and CNSL: P ratio of the resin on the properties of the synthesized resin are covered in the second chapter. Study of the adhesive properties of CNSL based resin in combination with neoprene rubber is included in the third chapter. The effect of varying the stoichiometric ratio between total phenol and formaldehyde and CNSL: phenol ratio of the resin, resin content, choice and extent of fillers and adhesion promoters in the adhesive formulation is studied. The effect of incorporation of the resin on the ageing properties of various elastomers is outlined in the fourth chapter. CNSL as such and resins with different phenol: formaldehyde ratios and CNSL: phenol ratios at different concentrations are incorporated into elastomers and the mechanical properties are determined. Effect of moulding conditions and stoichiometry of the resin on the properties of particleboard made from CNSL- formaldehyde resin is described in the fifth chapter. The major findings of the study are summarized in the last chapter. List of abbreviations and symbols are given at the end of the thesis and references at the end of each chapter.

Dr. Eby Thomas Thachil, Reader, Department of Polymer Science and Rubber Technology, Cochin University of Science and Technology, Cochin, my supervising teacher was the main source of encouragement and support in the progression of this work. With profound gratitude I acknowledge my indebtedness

for his inspiring guidance, competent advice and help without which the successful completion of this work would not have been possible.

I am extremely grateful to Dr. Thomas Kurian, Head of the Department of Polymer Science and Rubber Technology and Dr. A.P. Kuriakose, Dr. K.E. George and Dr. Rani Joseph former Heads of the Department for providing me all facilities during my research work. I express my sincere gratitude to my teachers especially Dr. Philip Kurian and Dr. Sunil K. Narayanankutty for their help, support and valuable suggestions throughout the course of this work. My special thanks to Dr. Beena T. Abraham for her motivation and support.

I thank all the non-teaching staff of the Department for their assistance. Words are insufficient to express my gratitude to Sreelatha, Jaya, Preetha, Bipin, Joby, Rajesh and Litty for their help in completing this work.

The support and encouragement of my parents are deeply acknowledged.

Above all, I thank for the grace of the Almighty God.

**Mary Lubi C.**

## ABSTRACT

This research project aims at developing new applications for CNSL in the polymer field. Cashew nut shell liquid (CNSL) is a cheap agro-byproduct and renewable resource which consists mainly of substituted phenols. By using CNSL in place of phenol, phenol derived from petrochemicals can be conserved and a cheap agro-byproduct utilized.

In this study CNSL based resin is prepared by condensing a mixture of phenol and CNSL with hexamethylenetetramine and the effect of P: F ratio and CNSL: P ratio on the properties of synthesized resin is studied. The adhesive properties of CNSL based resin in combination with neoprene rubber are investigated. The effect of varying the stoichiometric ratios between total phenol and formaldehyde and CNSL and phenol of the resin, resin content, choice and extent of fillers and adhesion promoters in the adhesive formulation are studied. The effect of resin on the ageing properties of various elastomers is also studied by following changes in tensile strength, elongation at break, modulus, tear strength, swelling index and acetone soluble matter. Crude CNSL and resins with different P: F ratios and CNSL: P ratios are incorporated into elastomers. Lastly, utility of CNSL based resin as binder for making particleboard is investigated.

The results show that CNSL based resin is an effective ingredient in adhesives for bonding aluminium to aluminium. The resin used for adhesive formulation gives the best performance at 45 to 55 phr resin and a total phenol: formaldehyde of 1:2.9. The resin when added at a rate of 15 phr improves ageing characteristics of elastomers with respect to mechanical properties. The reaction mixture of CNSL and hexa and the resin resulting from the condensation of CNSL, phenol and hexa can be used as effective binders for moulding particleboard.

# *Chapter 1*

## **INTRODUCTION AND LITERATURE SURVEY**

---

### 1.1 CASHEW NUT SHELL LIQUID

1.1.1 Composition

1.1.2 Extraction

1.1.3 Refining

1.1.4 Physical properties

1.1.5 Reactions of CNSL

1.1.6 Applications

### 1.2 CNSL BASED ADHESIVES

1.2.1 Adhesives

a. Ingredients

b. Elastomer based adhesives

c. Thermoset adhesives

d. Thermoplastic adhesives

e. Adhesive alloys

1.2.2 Neoprene adhesives

1.2.3 Phenolic adhesives

1.2.4 CNSL based adhesives

### 1.3 AGE RESISTORS FROM CNSL

1.3.1 Mechanism of ageing

1.3.2 Phenolic age resistors

1.3.3 Other age resistors

## 1.4 POLYMER WOOD COMPOSITES FROM CNSL

### 1.4.1 Particleboard

- a. Wood fillers- different forms
- b. Ingredients of particleboard
- c. Properties and uses of particleboard

### 1.4.2 Plywood

- a. Ingredients of plywood
- b. Properties and uses of plywood

### 1.4.3 Fiberboard

- a. Ingredients of fiberboard
- b. Properties and uses of fiberboard

## 1.5 CNSL BASED PHENOLIC RESIN

## 1.6 SCOPE AND OBJECTIVES OF THE WORK

## REFERENCES

## INTRODUCTION AND LITERATURE SURVEY

This research project aims at developing new applications for cashew nut shell liquid (CNSL) in the polymer field. Cashew is widely cultivated in the tropics and cashew nut is a very proteinaceous tasty product popular throughout the world. CNSL is a byproduct of the cashew nut processing industry. It is cheap, renewable and underutilized.

### 1.1 CASHEW NUT SHELL LIQUID

Cashew nut shell liquid (CNSL) occurs as a viscous liquid in the soft honeycomb of the shell of the cashew nut. Cashew nut is the crop of the cashew tree, *Anacardium occidentale L* (1) native to Brazil. The plant may grow to 12 m in height. The tree also produces cashew apple, wood suitable for boats, charcoal etc., and a gum similar to gum arabic. Cashew nut is greenish gray in colour and is attached to the cashew apple, which when ripe is either bright yellow or red. The nut has two walls or shells, the outer one being smooth and somewhat elastic and olive green in colour before maturity. The honeycomb is housed between the inner and outer shells. The kernel is inside the shell and is covered with a brown skin known as testa. Industrial grade CNSL is reddish brown in colour. CNSL constitutes about 20-25% of the weight of the cashew nut.

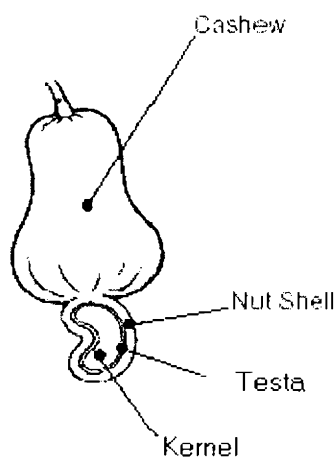

Fig.1 Cashew nut

The main constituents of CNSL are phenolic compounds with long side chain substitution at the meta position. These compounds give most of the reactions of phenol and can be the basis for producing a number of polymeric substances of wide utility in industrial applications. CNSL being cheap can be a substitute for phenol in many applications. The use of CNSL in place of phenol is an excellent example of conservation of a synthetically derived substance and the utilization of a cheap agro by-product. In the modern context, CNSL occupies a position of importance because of its renewable nature (2). CNSL is abundantly available in many parts of the world, such as India, Brazil, Bangladesh, tropical regions of Africa and South America. In some of these regions, cashew is a popular plantation product, while some others import cashew nuts for processing.

Demand for CNSL stems from its numerous uses in many areas. Constituents of CNSL possess special structural features for conversion into specialty chemicals and high value polymers. This involves substantial value addition and the chemical transformation provides 100% chemically pure products.

India is the largest producer of raw cashew nuts in the world. The production of raw cashew nuts was 95,000 MT during 2003-04. The export of CNSL from India during 2003-04 was 7215 MT. Among Indian States, Maharashtra comes first in production of cashew nuts followed by Kerala and Andhra Pradesh. Export of CNSL from Kerala was 6784 MT during 2003-04 (3).

### 1.1.1. Composition

The earliest work published concerning the composition of cashew nut oil is by Staedeler (4). Since then many researchers have investigated the constitution of the oil (5-7). Naturally occurring CNSL contains mainly four components: cardanol, cardol, anacardic acid, and 2-methyl cardol. Figure 1.2 shows the chemical structure of these compounds.

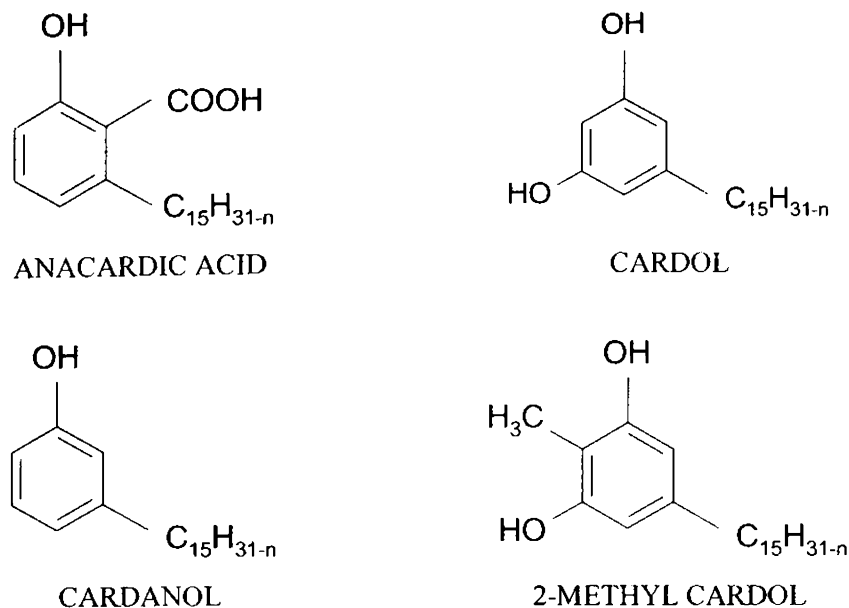
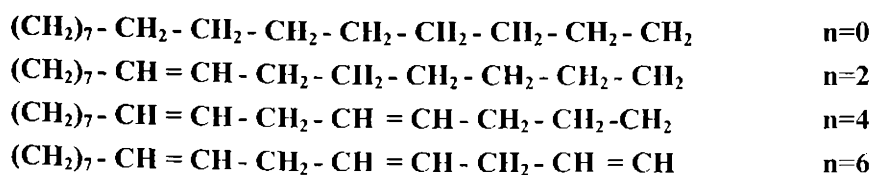

**Fig. 1.2 –Components of CNSL**

Commercial grade CNSL contains hardly any anacardic acid because of decarboxylation during the roasting process, which converts anacardic acid to cardanol (8). The roasting process also leads to polymerisation, which accounts for 20-25% of polymeric substances in the oil. Crude CNSL is corrosive but becomes less so by decarboxylation and removal of H<sub>2</sub>S during the refining process. The effect of processing parameters on the refining of CNSL has been studied (9).

The components of CNSL are themselves mixtures of four constituents differing in side-chain unsaturation, namely saturated, monoene, diene, and triene. The structures of the side chains of varying degrees of unsaturation occurring in the four major components of CNSL are identical. Fig. 1.3 shows the linear structures.

C<sub>15</sub>H<sub>31-n</sub> =



**Fig. 1.3 Components of the side chain**



Thus CNSL contains a total of 16 monomeric substances. CNSL is the only naturally occurring alkenyl phenolic substance.

Paul and Yeddanapally (10) identified the components of anacardic acid as 2-hydroxy-6-(n-pentadecyl)benzoic acid, 2-hydroxy-6-(n-pentadeca-8-enyl)benzoic acid, 2-hydroxy-6-(n-pentadeca-8,11-di-enyl)benzoic acid, 2-hydroxy-6-(n-pentadeca-8,11,14-trienyl)benzoic acid. Table 1.1 lists the constituents of anacardic acid as determined by various techniques.

**Table 1.1**  
**Composition of the constituents of anacardic acid as determined by various techniques (values are in wt %) (7)**

| Constituents of anacardic acid | Technique employed        |        |          |         |      |                       |
|--------------------------------|---------------------------|--------|----------|---------|------|-----------------------|
|                                | Low temp. crystallization | TLC-UV | TLC-grav | TLC-GLC | HPLC | TLC-mass spectrometry |
| Saturated                      | 4                         | —      | —        | 4       | 4.3  | 3.6 52.2-3            |
| Monoene                        | 15                        | 38.7   | 38.4     | 38.3    | 33.4 | 18.19 25-33.3         |
| Diene                          | 44                        | 16.3   | 17.3     | 17.3    | 19.9 | 16.5 17.8-32.1        |
| Triene                         | 37                        | 45.1   | 44.1     | 40.4    | 42.4 | 41.62 36.3-50.4       |

Symes and Dawson (11) and Cornelius (12) identified the components of cardanol as 3-(n-pentadecyl)phenol, 3-(n-pentadeca-8-enyl)phenol, 3-(n-pentadeca-8,11-di-enyl)phenol, 3-(n-pentadeca-8,11,14-trienyl)phenol. Table 1.2 gives the composition of the constituents of cardanol.

**Table 1.2**  
**Composition of the constituents of cardanol as determined by various techniques (values are in wt %) (7)**

| Constituents of cardanol | Technique employed     |                   |         |      |                       |             |
|--------------------------|------------------------|-------------------|---------|------|-----------------------|-------------|
|                          | Molecular distillation | Argentated column | TLC-GLC |      | TLC-mass spectrometry |             |
| Saturated                | —                      | 5.4               | 2.68    | 3.11 | 1.98                  | 3.94-4.35   |
| Monoene                  | 60                     | 48.5              | 29.5    | 36.1 | 31.31                 | 21.64-32.2  |
| Diene                    | 10                     | 16.8              | 16.6    | 20.1 | 15.23                 | 15.36-18.22 |
| Triene                   | 30.6                   | 29.3              | 51.2    | 40.6 | 51.47                 | 45.23-58.9  |

The same group of workers also identified the components of cardol as 5-(n-pentadecyl)1,3-benzene diol, 5-(n-pentadeca-8-enyl)1,3-benzene diol, 5-(n-pentadeca-8,11-di-enyl)1,3-benzene diol, 5-(n-pentadeca-8,11,14-trienyl)1,3-benzene diol,

The composition of the constituents of cardol is given in Table 1.3.

**Table 1.3**  
**Composition of the constituents of cardol as determined by various techniques (values are in wt %) (7)**

| Constituents of cardol | Technique employed |      |                       |             |
|------------------------|--------------------|------|-----------------------|-------------|
|                        | TLC-GLC            |      | TLC-mass spectrometry |             |
| Saturated              | 0.3                | —    | 0.24                  | 0.19-2.7    |
| Monoene                | 8.1                | 9.6  | 10.74                 | 8.43-15.15  |
| Diene                  | 21.9               | 25.2 | 20.64                 | 24.2-28.92  |
| Triene                 | 69.7               | 62.2 | 68.39                 | 36.46-67.18 |

Tyman (6) established the components of 2-methyl cardol as 2-methyl-5-(n-pentadecyl) 1,3-benzene diol, 2-methyl-5-(n-pentadeca-8-enyl) 1,3-benzene diol,

2-methyl-5-(n-pentadeca-8,11-di-enyl)1,3-benzene diol, 2-methyl-5-(n-pentadeca-8,11,14-trienyl)1,3-benzene diol.

The relative proportions of the saturated and unsaturated constituents of 2-methyl cardol are shown in Table 1.4.

**Table 1.4**  
**Composition of the constituents of 2-methyl cardol as determined by various techniques (values are in wt %) (7)**

| Constituents of 2-methyl cardol | Technique employed |      |                       |             |
|---------------------------------|--------------------|------|-----------------------|-------------|
|                                 | TLC-GLC            |      | TLC-mass spectrometry |             |
| Saturated                       | 1.66               | 2.43 | 3.92                  | 0.96- 1.34  |
| Monoene                         | 13.9               | 15.3 | 18.42                 | 16.27-25.28 |
| Diene                           | 18.5               | 20.4 | 20.15                 | 20.56-24.36 |
| Triene                          | 65.9               | 61.5 | 57.5                  | 49.82-62.2  |

Table 1. 5 give typical compositions of natural and technical CNSL.

**Table 1. 5**  
**Phenolic composition of natural and technical CNSL (values in wt %) (7)**

| Component       | Natural CNSL | Technical CNSL |
|-----------------|--------------|----------------|
| Cardanol        | 1.2          | 62.86          |
| Cardol          | 11.31        | 11.25          |
| 2-methyl cardol | 2.04         | 2.08           |
| Polymer         | 20.3         | 23.8           |
| Anacardic acid  | 64.93        | -              |

The phenolic nature of the constituents of CNSL along with varying degrees of unsaturation in the side chain makes it a highly polymerisable substance amenable to a variety of polymerisation reactions. Of overriding importance, however, is the condensation reaction with active methylenes that formaldehyde exemplifies. This leads to a phenol- formaldehyde type condensation.

### **1.1.2. Extraction**

A process for extracting CNSL has been patented in India in September 1961 (13). Traditionally, a number of methods are employed to extract the oil from the nuts. Often a particular region follows a technique by convention rather than by deliberate choice. The following are the popular methods currently employed for the extraction of the oil (6).

#### **a. Hot oil bath method**

The raw nuts are passed through a bath of hot CNSL at 180- 200<sup>0</sup>C. The outer part of the shell bursts open and releases CNSL. About 50% of the oil is thus recovered. This process makes the disintegration of nuts easy, without adversely affecting the quality of the kernels. Improvements over this basic technique include initial surface wetting and dipping in water at 20-25<sup>0</sup>C and subsequent steam treatment prior to exposure to the hot CNSL bath. The excess moisture content of 7-10% of the weight of the nuts causes the cells to burst, with the result that the oil oozes into the bath. Another 20% could be extracted by passing the spent shells through an expeller and the rest by a solvent extraction technique. The expeller oil can be upgraded by acid washing followed by centrifugation and heating.

#### **b. Roasting method**

Sudden exposure to higher temperature from ambient is the basis of this method. The shells are charred during this process, producing an explosive pressure in the cellular structure, which forces the liquid out of the shell. In drum roasting the nuts are heated at high temperature in a rotating drum and then shelled. One variation of this method is abrading at 100-300<sup>0</sup>C for about 1 hour and subsequent roasting at 400-700<sup>0</sup>C in an inert atmosphere. In yet another patent, the nuts are first abraded and then treated with moisture and heated in an infrared oven. Finally they pass through a high frequency electric field, where the liquid flows out. Often this technique is employed in conjunction with an expeller, where the oil is expelled from the shells to an extent of 90%.

**c. Miscellaneous methods**

CNSL is expelled by exposing the shell to superheated steam at temperatures ranging from 150<sup>0</sup>C to 300<sup>0</sup>C (14). Extraction of the oil by solvents such as benzene, toluene, petroleum hydrocarbon solvents or alcohols (15) or with supercritical CO<sub>2</sub> and water are other reported techniques (16). Report of a power operated cashew nut sheller has also appeared (17).

**1.1.3. Refining**

Sulfides, nitrogenous materials, and minerals contained in crude CNSL directly affect the quality of the oil. Hence CNSL is often subjected to chemical treatment with substances such as hydrocarbon sulfates and sulfuric acid before industrial use. Several acid treatment processes have been found to reduce the poisoning or vesicant action. Aqueous solutions of acids such as hydrochloric acid, sulfuric acid, acetic acid, chloroacetic acid or phosphoric acid, or acid sulfates such as sodium hydrogen sulfate are employed for this purpose. This performs two important functions: mineral salts of ammonium, calcium and potassium are precipitated and there is a reduction in the content of skin vesicant present in CNSL. The chemical treatment is accompanied by the evolution of hydrogen sulfide. The reduction in sulfur content has been found to correspond roughly to the removal of the agent responsible for the skin irritation. Treatment with amines or with hydroxides of the metals of group IA or IIA has been found to reduce the cardol content.

The refined CNSL can be readily distilled under reduced pressure or hydrogenated, both processes leading to products with good colour stability. Steam treatment of H<sub>2</sub>SO<sub>4</sub> treated CNSL followed by distillation has been found to deodorize the oil to a substantial extent.

Physical constants of CNSL before and after chemical treatment are summarized in Table 1.6 (18).

**Table 1.6 (18)**  
**Physical components of the oil before and after chemical treatment**

|                        | Raw oil       | Treated oil   |
|------------------------|---------------|---------------|
| Iodine no., Wijs       | 269           | 254           |
| Refractive index, 20°C | 1.5158-1.5162 | 1.5212-1.5218 |
| Specific gravity, 25°C | 0.958         | 0.96          |
| Saponification value   | 19.6          | 29.7          |
| Viscosity at 25°C, cp  | 400           | 435           |
| Acetyl value           | 173           | 156           |

#### 1.1.4. Physical properties

CNSL is dark viscous oil with a characteristic smell, quite unlike other vegetable oils. It is opaque and when applied as a thin film, is reddish-brown in color. It is immiscible with water but miscible with most organic solvents. CNSL has germicidal and fungicidal properties. It is used traditionally as a cure for acne vulgaris of the feet in Kerala. Table 1.6 gives some of its physical properties.

#### 1.1.5. Reactions of CNSL

The chemical structure of CNSL is such that it can take part in a large number of reactions. A few reviews have appeared summarizing the known reactions of CNSL (6, 19). The reaction schemes given in the following sections are based on cardanol, the major constituent of CNSL.

##### a. Decarboxylation

As mentioned earlier, anacardic acid decarboxylates on heating to cardanol. Fig. 1.4 shows the chemical changes taking place during decarboxylation (19).

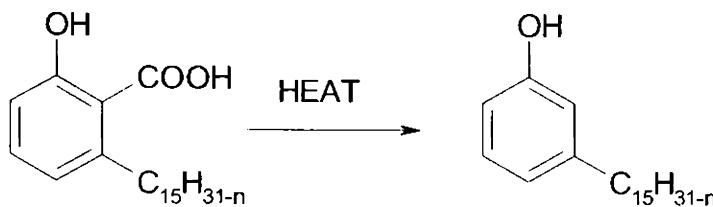

**Fig. 1. 4. Decarboxylation of CNSL.**

### b. Hydrogenation (20)

Hydrogenation is usually carried out using hydrogen and catalysts such as copper, nickel, palladium and platinum (Fig. 1.5).

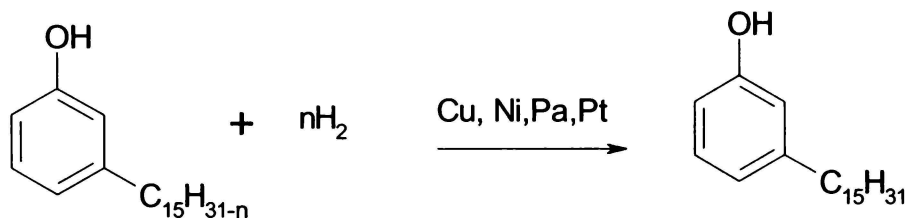

Fig. 1.5 Hydrogenation of cardanol

### c. Polymerisation

CNSL can be polymerized by a variety of techniques. The unsaturation in the side chain can be the basis for addition polymerisation (21-23) using free radicals or ionic initiators. Acids such as  $\text{H}_2\text{SO}_4$ ,  $\text{HCl}$ , paratoluenesulphonic acid (PTSA) etc. can give polymeric products. CNSL can be polymerized using salts such as zinc chloride, stannic chloride, ferrous sulphate, aluminium sulphate, boron trifluoride and salts of iron, cobalt, nickel, boron, chromium, lead, silver, mercury, manganese, etc. These salts are generally used to the extent of 1-6%.

The phenolic properties of CNSL are utilized to make condensation polymers by reaction with formaldehyde, furfural, HMTA, etc. (24-26). These polymers are similar to the product of phenol and formaldehyde condensation but shows less reactivity during synthesis and later during crosslinking. Both resole and novolac type resins can be made.

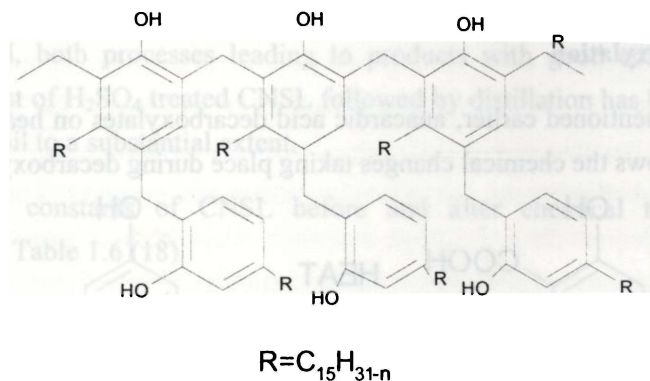
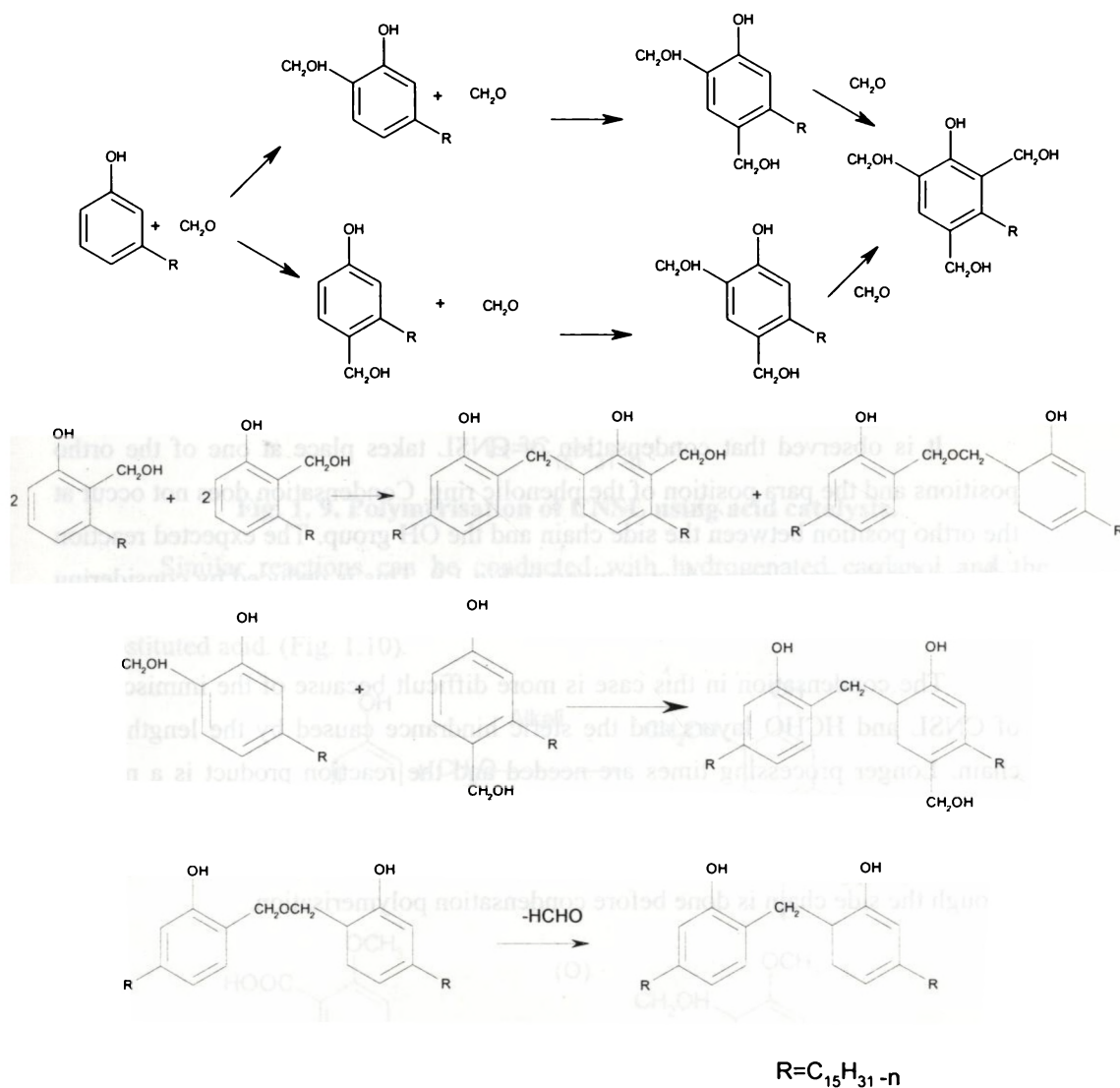

Fig. 1.6. Resole resin made from cardanol (7)

In the presence of alkaline catalysts and with more formaldehyde, the methylol phenols condense either through methylene linkages or through ether linkages. In the case of resole type polymers, the structure of the final product has been studied by Tyman (7) (Fig. 1.6). Working back from this structure and in analogy with similar reactions for phenol the reaction scheme leading to this final crosslinked network can be given as shown in Fig. 1.7.



**Fig. 1.7. Polymerisation of CNSL using alkali catalysts.**



In the presence of acid catalyst and with less formaldehyde, the resin has no reactive methylol groups and therefore is incapable of condensing with other molecules on heating in the absence of hardening agents. To complete resinification, more formaldehyde is added, resulting in crosslinking. The final structure of the novolac product has also been given by Tyman (Fig. 1.8).

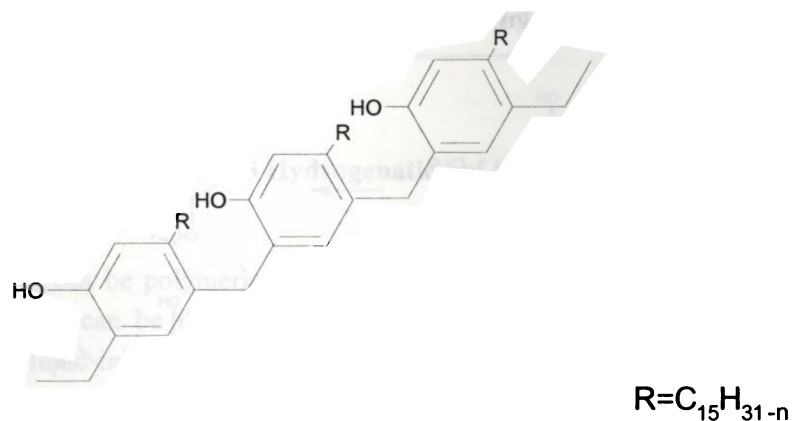

**Fig. 1.8. Novolac resin made from cardanol (7)**

It is observed that condensation of CNSL takes place at one of the ortho positions and the para position of the phenolic ring. Condensation does not occur at the ortho position between the side chain and the OH group. The expected reaction scheme for the novolac product is given in Fig 1.9. This is deduced by considering the final polymer structure and the reaction of phenol under similar conditions.

The condensation in this case is more difficult because of the immiscibility of CNSL and HCHO layers and the steric hindrance caused by the lengthy side chain. Longer processing times are needed and the reaction product is a mushy, high viscosity substance, which tends to solidify at comparatively low degrees of polymerisation. In certain applications, a preliminary step of polymerisation through the side chain is done before condensation polymerisation.

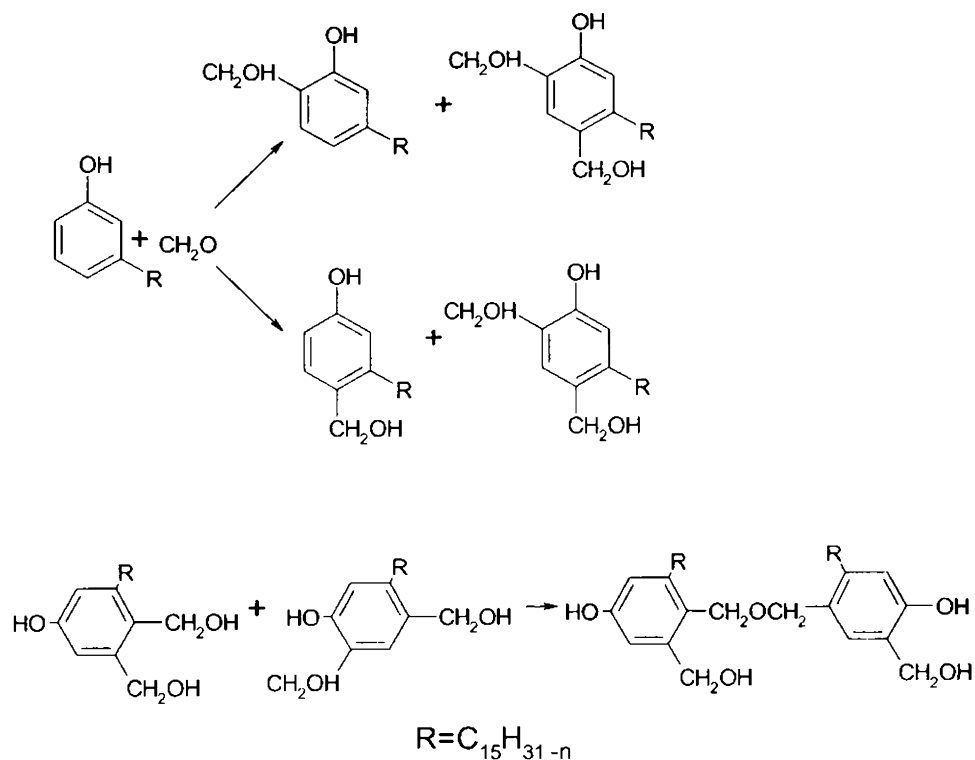

**Fig. 1. 9. Polymerisation of CNSL using acid catalysts.**

Similar reactions can be conducted with hydrogenated cardanol and the product converted to methyl ether and then oxidized with  $KMnO_4$ , giving a substituted acid. (Fig. 1.10).

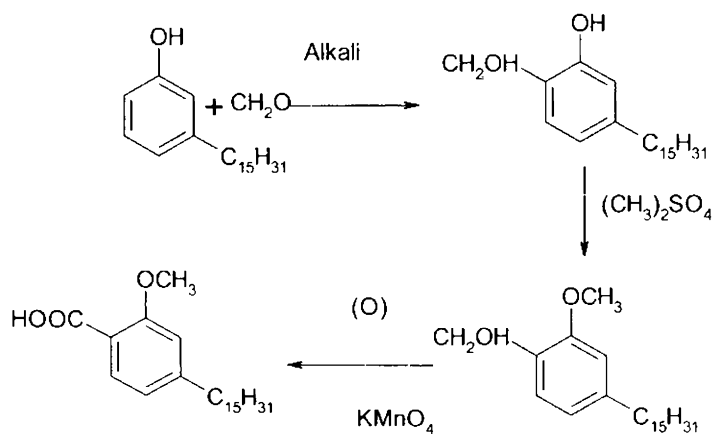

**Fig. 1.10. Condensation of hydrogenated cardanol followed by etherification and oxidation.**

Mishra and Pandey have investigated the kinetics of alkali catalyzed formaldehyde condensation after thoroughly reviewing the results previously reported by various workers (27). O'Conner and Blum have studied the thermal stability of some formaldehyde condensate resins (28).

The structure and properties of CNSL novolac resin prepared using succinic acid as a catalyst has been investigated (29). The synthesis and characterization of a large number of resins using different hydroxy aromatic compounds, formaldehyde, furfural, and substituted aromatic compounds like CNSL in the presence of acid and base catalysts have been studied (30, 31).

Oxidation polymerisation using acid oxidizers such as  $\text{HNO}_3$  can also give polymers, which have proved to be excellent for surface coatings and paper/fabric impregnation (32). CNSL on treatment with copper, lead, aluminium etc. undergoes polymerisation. The air drying qualities of CNSL were found to improve by this. Enzymatic polymerisation of alkyl phenols derived from CNSL has been carried out in a dioxan-water mixture (33).

When CNSL is simply heated to  $200^\circ\text{C}$  or above, it undergoes polymerisation. Cationic, anionic or oxidizing agents can accelerate the process. Alkalis can also be used as catalysts for the polymerisation of CNSL by heat. The first step is usually the reaction of phenolic hydroxyl with the alkali, and the compound thus obtained acts as a catalyst for the polymerisation (19).

Mono or dialkyl sulphates in concentrations of about 2% have been used to polymerize CNSL at about  $160^\circ\text{C}$ . The advantage of using alkyl sulphates is that metal present as impurities in CNSL are precipitated out during polymerization (34)

#### **d. Sulfonation (35)**

CNSL derivatives can be sulphonated to yield alkyl aryl sulphonic acid or their metal salts. The reaction is carried out using concentrated  $\text{H}_2\text{SO}_4$  at  $108^\circ\text{C}$ . The reaction scheme shown in Fig. 1.11 employs hydrogenated cardanol.

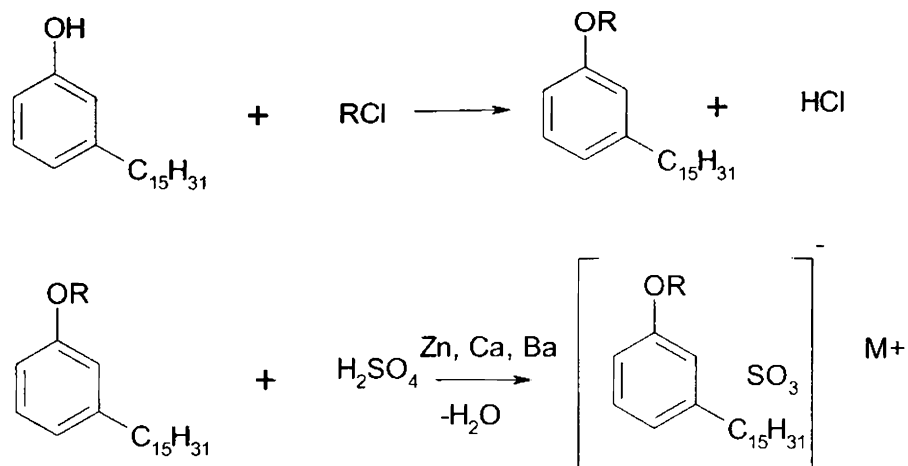
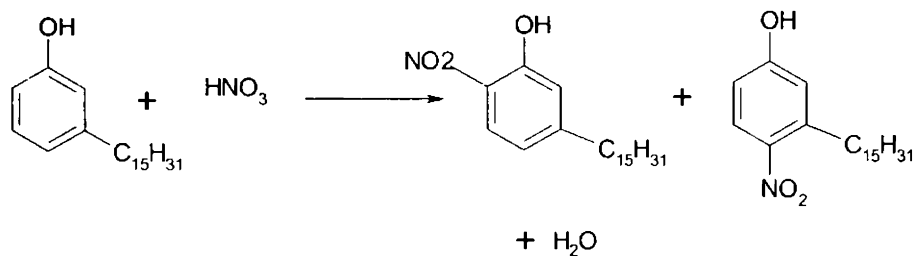

**Fig. 1.11. Sulfonation of hydrogenated cardanol.**

To prevent polymerisation during sulphonation, an aryl or alkali group is substituted for hydrogen and the double bonds of the aliphatic side chain are saturated by hydrogenation before treatment with the acid.

#### e. Nitration (19)

Direct nitration of cardanol or CNSL leads to simultaneous oxidation and polymerisation. By nitration of hydrogenated cardanol, 4-nitro compound and 6-nitro compound were obtained. Nitroderivatives of cardanol are very efficient antioxidant for gasoline, mineral hydrocarbons, petroleum products and lubricating oils (Fig. 1.12) (36-38).



**Fig. 1.12. Nitration of cardanol.**

#### f. Halogenation (39)

Halogenation of CNSL can be accomplished with comparative ease. For example, chlorine gas can be passed through CNSL dissolved in kerosene to obtain

15% (w/w) chlorination. Chlorinated CNSL reacts with active methylenes at a faster rate and are more flame resistant. The halogenation is accompanied by polymerisation and thickening and a large exotherm.

**g. Etherification (40)**

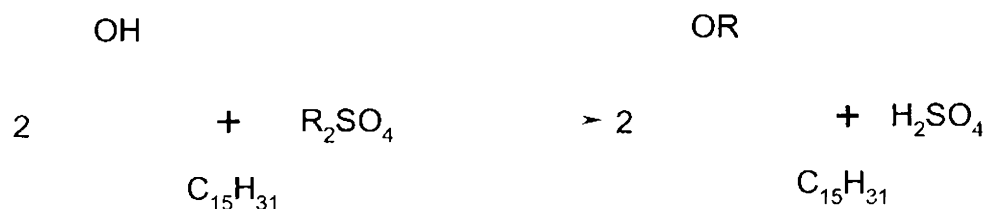
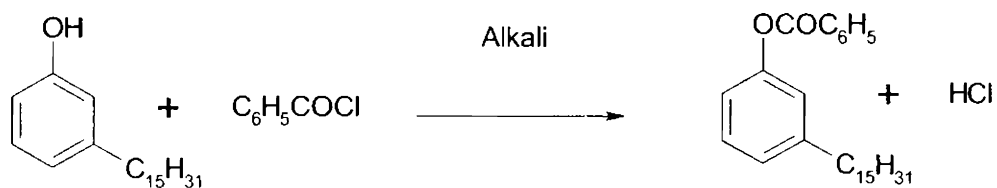

**Fig. 1.13. Etherification of cardanol.**

Cardanol can be reacted with dialkyl sulphates in presence of alkalis to give dialkyl cardanols. Fig. 1.13 shows the chemical changes during etherification.

**h. Esterification (41)**

Cardanol can be reacted with acid chlorides in the presence of alkalis to give cardanol esters. Thus benzoyl chloride gives benzoyl cardanol (Fig. 1.14). Various other esters of industrial importance have also been reported (38).



**Fig. 1.14. Esterification of CNSL.**

### i. Epoxidation (42)

Epoxidation of the phenolic group can be accomplished by the reaction of CNSL with epichlorohydrin. The chemical changes during this reaction are shown in Fig. 1.15. Epoxy resin can also be prepared from glycidyl ethers by reaction with CNSL.

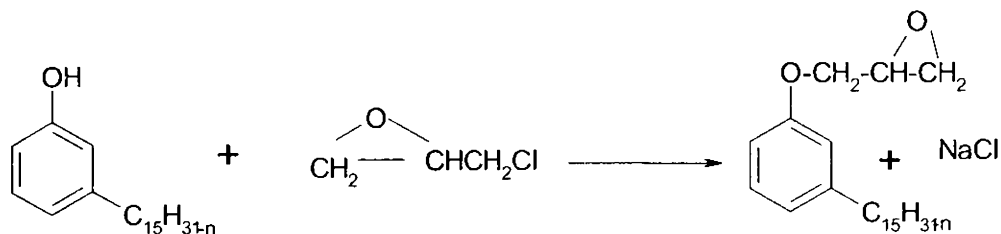

Fig. 1.15. Epoxidation of cardanol.

According to Kamath et al., reaction product of cardanol and phenol when reacted with epichlorohydrin produced epoxy resin which claimed to be superior to conventional epoxy resin (43)

### j. Miscellaneous reactions

Pillai and co-workers (44-50) have investigated the phosphorylation of cardanol and the prospective applications of the products. Urethanes have been synthesized from CNSL as in the case of other hydroxy compounds, by reaction with isocyanates (51). CNSL can be converted to acetals by reaction with compounds like dimethyl acetal in presence of acids (19). Isocyanates have been prepared from hydrogenated cardanol (52). Azo dyes are made by the reaction of phenols with primary aromatic amines after diazotization of hydrogenated cardanol (53). By reacting CNSL with triethylene-tetramine, phenolic polyamines can be prepared (54). Benzotriazole derivatives are prepared from hydrogenated cardanol by diazotizing with aromatic amines followed by reduction. Syrenation of CNSL resin can be done by reacting styrene with CNSL hexamine condensate (55).

#### 1.1.6. Applications

Polymers derived from CNSL have certain outstanding properties which make them unique for many applications. The most attractive aspect of CNSL as a

starting material is its low cost. The polymer shows flexibility due to internal plasticization resulting from the presence of the long side chain. This long aliphatic side chain also gives water resistance. It has low fade characteristics, which make it a desirable component of brake lining formulations. It is compatible with a wide variety of polymers such as alkyds, melamines, polyesters etc. Its ready solubility in a number of common solvents makes it a natural choice for a large number of surface coating applications. There have been a number of reviews on the applications of CNSL-based materials (56-82).

**Consumption of CNSL by Indian Industry (Estimated) in 2003 (Mega tons)**  
(83)

|                    |           |
|--------------------|-----------|
| Break linings      | 1200-1400 |
| Paints and varnish | 600-800   |
| Lamination         | 900-1000  |
| Foundry            | 400-500   |

**a. Brake linings and clutch facings**

CNSL and cardanol based resins have found extensive uses in automotive brake lining applications as binders/friction property modifiers. CNSL polymers are a natural choice for this application because of an excellent blend of properties such as low hardness, abrasion resistance, longer retention of breaking efficiency, low fade characteristics, better water repellence and low cold wear (83, 84)

Addition of friction dust gives a silent braking action, which is highly desirable in modern times. About 12,000-15,000 tons of brake linings are produced for use in motorcars every year in the country. With increasing use of automobiles, there is an expanding market for brake lining applications.

In brake lining materials, two types of CNSL products are used:

1. CNSL resin as a partial substitute for phenolic resin to reduce cost and
2. CNSL based friction material (friction dust) to modify the friction and wear properties of brake linings.

Modified CNSL resin can substitute phenolic resin totally and meet all the specifications of brake linings. Additionally it improves impact properties and reduces fade.

Friction dust is added to brake linings to modify the frictional and wear properties of brake linings. It also provides properties similar to that of CNSL matrix resin. Formulations for excellent fade characteristics, enhanced thermal stability, good resistance to noise, high resistance to hygroscopy, corrosion resistance, rust resistance and low brake noise have been reported (85-100). Friction dust is generally prepared by crosslinking CNSL formaldehyde resin with hexamine / paraformaldehyde and powdering the product to the required specifications. Modified friction dust for applications in 'hot wear' conditions can be prepared from modified CNSL resin.

#### **b. Surface coatings**

The chemically stable nature of CNSL, the solubility of the resin in various solvents, the inherent hydrophobicity and chemical resistance, the film forming nature, anti-termite, anti-microbial properties, and a high degree of unsaturation make CNSL polymers highly suitable for surface coating applications. The formulation and manufacture of various classes of paints based on CNSL have been described by Ramanujam (101).

Films of high heat resistance, corrosion resistance, excellent electrical properties, anti-corrosive, water and solvent resistance properties, water based coatings etc. can be formulated from CNSL. CNSL based surface coatings possess excellent gloss and surface finish with optimum levels of toughness and elasticity. Because of the dark colour its uses are restricted to anticorrosion primers, black enamels, paints to prevent marine growth on structures, etc (102). Transparent resin from CNSL that can be used as a base for paint of all colours has been developed (103).

CNSL resins give excellent lacquers with decorative and protective properties. Lacquers from CNSL have been used as surface coatings for wood, porcelain, metal ware and so forth (104-115). The dried film of this lacquer is superior to ordinary oil paints in resistance against oils, grease, moisture and



chemicals. Lacquers for special applications such as screen lacquering and gold lacquering are prepared from CNSL.

CNSL resin based varnishes possess good insulating properties apart from their high water repellence and low dielectric properties. Although CNSL and its resins are highly susceptible to fire and burn easily, they can be successfully made fire resistant by incorporating flame retardant agents chemically or flame retardant fillers physically.

CNSL resins singly or in combination with other resins show excellent water and weather proofing properties and can be used for protection of roofs. Shirsalkar and Sivasamban have prepared anticorrosive paints based on CNSL, which have been found to be suitable for ships hulls and other such applications (116-117). The coating withstands alkalinity normally encountered with cathodically protected steel hulls. Rust inhibiting zinc rich primers can be prepared from CNSL. Coatings giving tough elastic films are reported from CNSL-glycerine reaction products (118).

### **c. Foundry**

The phenolic nature of CNSL facilitates the use of resin derived from it in place of conventional phenolic materials used in the foundry industry. The fire retardant and ablative properties associated with the phenolic structure are responsible for this. CNSL is being used as a substitute for linseed oil in the manufacture of foundry core oil used as binder in foundry. CNSL resin imparts good scratch hardness to sand cores after baking them. It also provides resistance to moisture and weathering, good green strength and surface finish to moulded articles (119). Modified CNSL resin when used as core binder is found to improve collapsibility of the core and enhances bench life and anti-damp behaviour in comparison to conventional core binders (76).

### **d. Laminates**

CNSL based resins improve the resistance to heat, the bonding with reinforcement materials and the flexibility of laminates while reducing brittleness and age hardening. Resins for laminated products are made from CNSL and phenol by reaction with aldehydes. Modified phenolic resins are used for making laminates

with good dimensional stability and warp resistance. Metal-polymer laminates of high inter laminar shear strength have been developed from CNSL (120).

#### **e. Miscellaneous applications**

CNSL forms the basic raw material for a vast number of industrially important chemicals. Patents and reports cite a number of applications such as antioxidants, bactericides, fungicides, disinfectants, insecticides, dispersing and emulsifying agents, dye stuffs, ion exchange resins, surfactants, stabilizers, curing agents etc (121-145). Lipid nanotubes can be prepared from CNSL (146). Applications of CNSL in adhesives and rubber compounding are discussed in sections 1.2 and 1.3

### **1.2 CNSL BASED ADHESIVES**

#### **1.2.1 Adhesives**

An adhesive is a substance that bonds two substrates by surface attachments. Adhesives can be categorized both in terms of their chemical composition or polymer type and their physical forms. Adhesive compositions include a number of additives such as plasticizers, tackifiers and fillers in their formulation. To enhance performance primers and coupling agents are sometimes employed.

Advantages of adhesive bonding are (1) they permit bonding of materials that are impractical to join in other ways (2) possibility of joining dissimilar materials (3) uniform stress distribution in the joints (4) enhanced environmental protection (5) resistance to vibration and shock (5) better aesthetic appeal (6) higher speed of production and lower cost etc.

On the other hand, adhesives can be sometimes relatively expensive, have high temperature limitations, often require surface preparation and require jigs, presses or other fixtures to hold parts in place until the adhesive cures (147-150).

#### **a. Ingredients**

The components of an adhesive mixture are usually determined by the need to satisfy application properties of the adhesive or properties required in the final joint.

1. **Binder** - The basic component of the adhesive formulation is the binder which provides the adhesive and cohesive strength in the bond. It is usually an organic resin but can be a rubber, an inorganic compound or a natural product.
2. **Diluent** – It is employed as a solvent vehicle for other adhesive components and also to provide viscosity control which makes a uniformly thin adhesive coating possible.
3. **Catalysts and hardeners** – These are curing agents for adhesive systems. Hardeners chemically combine with the binder material. The ratio of hardener to binder sometimes determines the physical properties of the adhesive. Catalysts are also employed as curing agents for thermosetting resins to reduce cure time and increase the crosslink density of the synthetic polymer.
4. **Accelerators, inhibitors and retarders**- These substances control the curing rate. Accelerators speed up the curing rate by combining with the binder. An inhibitor arrests the curing reaction. Retarder slows down the curing reaction and prolongs the storage or working life of the adhesive.
5. **Modifiers**- These are chemically inert ingredients added to adhesive compositions to alter their end use or fabrication properties. Modifiers include fillers, extenders, thinners, plasticizers, stabilizers and wetting agents.
  - i. **Fillers** are non adhesive materials which improve working properties, strength or other qualities of the adhesive bond.
  - ii. **Extenders** have some adhesive properties and are added as diluents to reduce the concentration of other adhesive components and thereby the cost of the adhesive.
  - iii. **Thinners** are volatile liquids added to modify the consistency or other properties.
  - iv **Plasticizers** are incorporated to provide the adhesive bond with flexibility.
  - v. **Stabilizers** are added to increase its resistance to adverse service conditions.
  - vi. **Wetting agents** promote interfacial contact between adhesive and adherend by improving the wetting and spreading qualities of the adhesive.

## **b. Elastomer based adhesives**

These materials are based on synthetic or naturally occurring polymers having superior toughness and elongation but lower modulus. Curing procedures vary depending on the type and form of adhesive. These adhesives can be formulated for a wide variety of applications, but they are generally used for their high degree of flexibility and superior peel strength.

These adhesives are used in unstressed joints on lightweight materials. So they cannot be considered as structural adhesives. They are particularly advantageous for joints in flexure. Most of these adhesives are modified with synthetic resins for bonding rubber, fabric, foil, paper, leather and plastic films.

### **1. Natural rubber (NR)**

NR is the most widely used of all elastomers in pressure sensitive adhesives. NR adhesives display excellent flexibility, rich initial tack and good tack retention. The most suitable grade of raw rubber for making adhesive solutions is pale crepe.

### **2. Styrene butadiene rubber (SBR)**

Styrene butadiene rubbers are copolymers of styrene and butadiene. They do not have outstanding adhesive properties but are cheaper and have better heat ageing properties than NR. SBR absorbs less water and reinforced compositions have higher strength retention.

### **3. Nitrile rubber (NBR)**

These materials are predominantly random copolymers of butadiene and acrylonitrile. Usually the copolymer contains enough acrylonitrile so that good resistance to oil and grease is obtained. The adhesive properties improve with increasing acrylonitrile content. NBR adhesives have outstanding shelf stability and high temperature properties. Because of the high polarity of nitrile rubbers, they show good adhesion to surfaces such as textile, paper and wood.

#### **4. Butyl rubber (IIR)**

Butyl rubber is a copolymer of isobutylene with a small amount of isoprene. This elastomer is non-crystallizing, has a largely saturated backbone, and is available in a wide range of molecular weights. Butyl adhesives are mainly used in sealants and caulks where resistance to oxidative degradation is important.

#### **5. Chloroprene**

Chloroprene is often used in contact cements. The basic components of the adhesives are the elastomer and about 30-35 phr reactive phenolic resin. The more rigid the rubber and complete the crystallization the shorter the open time and greater the ultimate peel strength of the bond. More details are given in Section 1.2.2

### **c. Thermoset adhesives**

Because thermosetting adhesives are densely crosslinked when cured their resistance to heat and solvents is good and they show little elastic deformation under load at elevated temperature. Bonds are ordinarily good to 93-260°C. Creep strength is good and peel strength fair. The major application is for stressed joints at somewhat elevated temperatures. Most materials can be bonded with thermosetting adhesives, but the emphasis is on structural adhesives.

#### **1. Epoxies**

The principal epoxies used for commercial adhesives are the reaction products of epichlorohydrin with dihydroxy compounds and include bisphenol A, novolacs and aliphatic glycols. Novolac based epoxies have functionalities greater than two and sometimes over five. They give adhesives of higher crosslink density and consequently, high heat resistance. The wide acceptance of epoxy adhesives is based on its high adhesion to many substrates, low shrinkage and creep, ability to formulate 100% solids and a large number of possible coreactants (151). Epoxies are used to bond metals, glass, ceramics, plastics, wood, concrete and other surfaces.

#### **2. Amino resins**

The condensation product of formaldehyde with urea or melamine is the important members of the amino resin class. The largest application of urea

formaldehyde resin is in bonding wood, principally in the manufacture of particleboard. In the furniture industry UF resin finds use as inexpensive adhesives. Consumption of melamine resins is about 1/5 that of urea resins because of the cost differential. Melamine resins are used where light color, resistance to solvents and abrasion are required.

### ***3. Polyesters***

Polyester hot melt adhesives are prepared by copolymerisation of multiple diacids or glycols. The principal use of polyester hot melt adhesives is in shoe and textile industries. Unsaturated polyesters which require a catalytic cure are used for the bonding of polyester substrates.

### ***4. Silicones***

Silicone adhesives are mainly used in construction industry because of their excellent physical properties, high elongation, chemical inertness and heat resistance.

### ***5. Polyurethanes***

Polyurethane adhesives are reactive adhesives, fully formed polymers applied from solution or used as films and aqueous dispersions. In reactive adhesives, the usual isocyanates used are toluene diisocyanate and diphenyl methane- 4, 4'-diisocyanate. Depending on the molar ratio of isocyanate to OH groups, the prepolymers may be either isocyanate or hydroxyl terminated. The isocyanate terminated prepolymers are usually applied from solution. Curing takes place by reaction with moisture often with the help of multifunctional compounds.

#### **d. Thermoplastic adhesives**

These materials do not crosslink during cure. So they can be resoftened repeatedly with heat. Thermoplastic adhesives are not ordinarily recommended for use over 66<sup>0</sup>C, although they can be used up to 90<sup>0</sup>C in some applications. These materials have poor creep resistance and fair peel strength. They are used mostly in unstressed joints and designs. The materials most commonly bonded are nonmetallic, especially wood, leather, cork and paper. Thermoplastic adhesives are not generally used for structural applications.

**1. Ethylene copolymers**

These materials are copolymers of ethylene and vinyl acetate. The most important ethylene copolymers for adhesive use are ethylene vinyl acetates (EVA) those containing 25-40% by weight of vinyl acetate. A high VA content in the copolymer leads to greater solubility, high tack in the adhesives, better adhesion to polar surfaces and better low temperature performance. EVA hot melt adhesives are used in bookbinding and pressure sensitive adhesives.

**2. Polyamides (nylons)**

Polyamides are employed as single component hot melts. A number of hot melt polyamides are produced by copolymerisation of multiple diacids or diamines. Polyamide hot melt adhesives are used in packaging textiles and in furniture, shoe and electronic industries. Excellent adhesion to plasticized PVC, porous materials and metals are reported for polyamides.

**3. Poly (vinyl acetate)**

PVAc is almost always used in emulsion form. The largest adhesive application of PVAc is in bonding paper. PVAc adhesives are used in bookbinding, bag seaming, tube winding, cup adhesives, remoistenable adhesives on stamps and envelopes, and for bonding various films to cellulosic materials. Polyvinyl alcohol derived from PVAc is used as a component of PVAc emulsions.

**4. Poly (vinyl acetal)**

Two commercial resins of this type of materials, poly (vinyl formal) and poly (vinyl butyral) are produced by the reaction of poly (vinyl alcohol) with formaldehyde and n-butyraldehyde respectively. They are used in structural bonding, primarily of metals, and for the manufacture of automotive safety glass. Poly (vinyl butyral) combined with plasticizers, extending resins and waxes are used as interlayer in laminated automobile safety glass. It currently dominates this area internationally.

## 5. Acrylics

Acrylic adhesives are derived from acrylate or methacrylate esters. An important industrial application of acrylic emulsions is in bonding nonwoven fabrics. Acrylates are used very widely in pressure sensitive adhesives. The principal constituents of these adhesives are either butyl or octyl acrylate, along with polar monomers such as acrylic acid or acrylamide.

Advantages of acrylic adhesives are tolerance for oily and otherwise poorly prepared surfaces, rapid bonding at room temperature, low shrinkage during cure, high peel and impact strength combined with excellent shear strength, good environmental resistance and elevated temperature properties (152).

### e. Adhesive alloys

These are made by combining resins of two different chemical nature chosen from the thermosetting, thermoplastic or elastomeric classes. The thermosetting resin, chosen for high strength, is plasticized by the second resin, making the alloy tougher, more flexible and more resistant to impact. The adhesive utilizes the most important properties of each component material. They are commonly available as solvent solutions and as supported and unsupported films.

Adhesive alloys used include epoxy – phenolic, epoxy – polysulphide, epoxy – nylon, nitrile – phenolic, neoprene – phenolic, vinyl – phenolic, polyvinyl acetal – phenolic etc.

### 1.2.2 Neoprene adhesives

Polymer structure of neoprene is determined by the manner in which the monomer 2 chloro-1, 3- butadiene reacts with the growing polymer chain. Upon polymerisation, chloroprene may take any of four isomeric forms shown in Fig.1.16

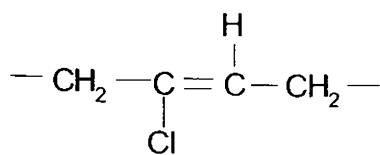

**Trans 1, 4 addition**

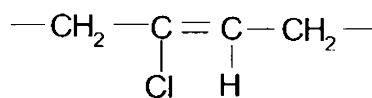

**Cis 1,4 addition**



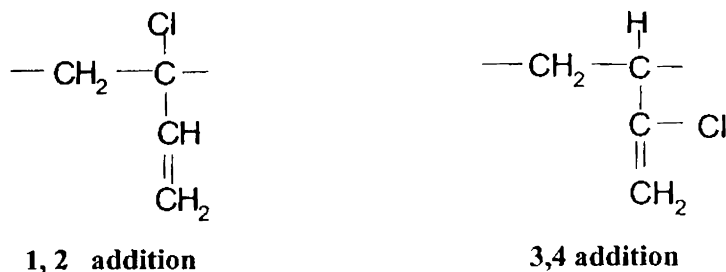

**Fig. 1.16 Structure of neoprene**

The proportions of these configurations in the polymer determine the amount of crystallization (trans 1, 4) and reactivity towards vulcanization (1, 2 addition). Rapid bond strength development of neoprene adhesives is associated with crystallization of trans configuration in which there is no side group bulkier than chlorine atom.

**Different grades of neoprene are**

*Neoprene AC:* General purpose, quick setting adhesive elastomer containing about 90% trans 1,4. It has good stability and cohesive strength

*Neoprene AD:* Similar to AC with better colour and viscosity stability.

*Neoprene AF:* Carboxylated, slow crystallizing rubber, develops cohesive strength rapidly and has excellent resistance at elevated temperatures.

*Neoprene HC:* The most rapidly crystallizing type and hence suitable for cold setting, heat sealable adhesives.

*Neoprene FB and FC:* Slow crystallizing, high viscosity fluid elastomer.

*Neoprene AT:* Highly reactive peptizable polymer that can be used as a base for pressure sensitive adhesives requiring high peel strength and flame resistance.

*Neoprene AG:* High gel polymer, provides improved application properties.

*Neoprene AH:* Dispersable, non crystallizing, chemically peptizable polymer.

*Neoprene W:* General purpose elastomer, non crystallizing, contains 85% trans 1,4 segments, good tack and low cohesive strength.

Neoprene adhesives are used as elastomeric binders because of high bond strength, bonding range, high ultimate strength and creep resistance, adhesion to

many surfaces, durability, flexibility, chemical resistance and resistance to burning. Strength of neoprene is associated with crystallization as the polymer is deposited from solution (153). Rapid bond strength development of neoprene contact adhesives is associated with crystallization resulting from high level of trans configuration in which there are no side groups bulkier than chlorine atom. The temperature and solvent resistance can be considerably increased by additional crosslinking with phenolic resins which also improves tack and adhesion. Thermal resistance is enhanced further by addition of bivalent oxides of the second main group and subgroup metals such as calcium and zinc. By increasing the amount of resin the heat resistance is raised, the elongation reduced and therefore brittleness of the adhesive layer enhanced. A 40-45% resin level seems to be the best compromise.

CR types with medium or strong crystallization tendency are preferred. CR is soluble in aromatic chlorinated hydrocarbons, in some esters, ketones and also in mixtures of certain non-solvents. The nature of the phenolic resin used influences the open time and peel strength to a great extent. The content of methyl groups and dimethylene ether bridges are the key factors which have to be coordinated with the crystallization tendency of CR. If the crystallization rate is high non-or less basic reactive phenols is of advantage (154).

A typical neoprene contact adhesive contains 100 parts neoprene, 45 parts t-butyl phenolic resin, 5 parts MgO, 2 parts ZnO and an antioxidant. Phenolic resin first reacts with MgO in the presence of water resulting in a three dimensional system. MgO also functions as an acid acceptor. Neoprene contact cements have important uses in shoe industry, automotive and construction industry.

### **1.2.3 Phenolic adhesives**

Phenolics are condensation products of phenol and formaldehyde. A large variety of phenolic resins are possible depending on (1) choice of phenol. (2) P: F ratio (3) type and amount of catalyst used (4) time and temperature of reaction.

Phenolic adhesives employed are provided either as one component, heat curable liquid solutions or powder, or as liquid solutions to which catalysts must be added. In general phenolic resin exhibits adhesive functions in all kinds of applications. Their adhesion to most materials is very good due to the marked

polarity of the phenolic structure. Disadvantages are their brittleness, the high curing temperature and pressure required and the limited shelf life of resol grades.

In structural adhesives, the phenolic resin for metal /metal and metal /rubber bonding are combined with elastomers or thermoplastics. By these combinations the characteristic properties of both can be utilized and specific requirements met by the ratio of resin and elastomer. As soft components polyvinyl acetate, NBR, polyamides and polyacrylates are preferred. The elongation, elasticity and resilience of the phenolic resin is improved considerably especially at low temperature by this binding. The toughening action of such polymer blends is attributed to chemical reaction and the morphology of the cured system. Because of the limited solubility of the thermoplastic or elastomeric component a discrete, discontinuous phase develops in the cured phenolic matrix. Crack propagation is considerably minimized by the two-phase system and the impact strength therefore improved.

Adhesives based on neoprene and NBR exhibit high green strength and excellent adhesion to various substrates. The strength, temperature and creep resistance can be improved and adhesive cost reduced by the addition of phenolic resins. Chloroprene adhesives yield high peel strength and have outstanding green strength properties. Nitrile adhesives exhibit excellent oil and grease resistance.

An important use of phenolic adhesives is in wood bonding where water resistance is required. Phenolics may be formulated as water dispersions, where penetration into the cell structure of wood is important for the formation of permanent bonds. Resorcinol-formaldehyde condensates are also used as wood adhesives. Resorcinol resins cure at room temperature under mildly alkaline conditions and are therefore used for wood bonding applications.

Unmodified phenolics are mainly used as primers, to prepare metal surfaces for bonding and as binders for such varied products as glass wool insulation mats, foundry sand, abrasive wheels and brakelining composites. Phenolic resins are also used in the manufacture of abrasive devices such as grinding wheels and sand papers. Laminates of various fabrics are prepared by impregnating the sheets with phenolic resin (155).

Other phenols used are cresol, p-nonyl phenol, p-phenyl phenol, p-tertiary butyl phenol, p-amyl phenol and p-octyl phenol. Phenols substituted at either the ortho or para positions are only difunctional, hence the resins are incapable of crosslinking to a useful thermoset structure. The meta substituted isomer is trifunctional and therefore crosslinking will occur.

#### **1.2.4 CNSL based adhesives**

The high polarity and inherent tackiness of phenolic materials and the ease with which liquid to solid conversion can be accomplished make CNSL a desirable starting material for adhesive formulations (156).

There are many reports and patents describing the use of CNSL polymers in adhesives. In these formulations resins derived from CNSL by various polymerisation and/or modification techniques are employed. Details are given in (157).

CNSL based adhesives exhibit admirable properties to meet the growing demand for quality and durability in bonding plywood. Low grade wood impregnated with CNSL resin shows remarkable upgrading of quality. These resins are used for the preparation of particleboards, bamboo boards, coconut leaf based boards etc. where both quality and cost effectiveness could be simultaneously achieved.

Polymerisation of CNSL with  $H_2SO_4$  as the catalyst followed by compounding with aldehyde type hardeners leads to cold setting adhesives (158). Polymerized CNSL obtained using HCl,  $HNO_3$ ,  $MnO_2$ , maleic acid or stearic acid as catalyst was found to be a good plywood adhesive (158). Alkali catalyzed CNSL-phenol- formaldehyde condensates compounded with  $CuCl_2$  or  $CaCO_3$  are excellent adhesives for plywood (160). Cold setting adhesives meeting Indian Standards specifications have been prepared from alkali catalyzed CNSL- phenol- formaldehyde resin and p- toluene sulphonic acid (161). Cure time of adhesives obtained from CNSL, phenol and formaldehyde was reduced when  $KMnO_4$  was used as accelerator (162). CNSL modified phenol- formaldehyde resins have been reported as useful adhesives for heat bonding metals to polymers (163). Heat curable adhesives have been prepared using a formulation consisting of CNSL resin and epoxy resin (164). Polymerisation of CNSL mixed with

paraformaldehyde has been used as cements for corrosion resistant tanks (165). An increase in self adhesion strength with storage time was observed for PCNSL modified NR (166)

In this study, adhesives consisting of resins derived from CNSL and neoprene rubber have been investigated for rubber- to- rubber, rubber-to- metal and metal- to- metal bonding.

### **1.3 AGE RESISTORS FROM CNSL**

The incorporation of CNSL has been found to improve the properties of rubber products. It aids processing and enhances the vulcanization properties (68). It also helps the incorporation of ingredients into rubber, increases its resistance to moisture, resistance to crack and cut and thermal stability.

#### **1.3.1 Mechanism of ageing**

The ageing of polymers occurs through a free radical process. Any form of energy – heat, light or mechanical stress can break polymer bonds to form carbon radicals (C $\cdot$ ) to start the degradation process. In the presence of oxygen, peroxy radicals (COO $\cdot$ ) are formed. The peroxy radical abstracts hydrogen from the polymer to generate another carbon radical and a hydroperoxide (COOH). The hydroperoxide decomposes under heat to form two or more free radicals, an alkoxy radical (CO $\cdot$ ) and a hydroxyl radical (HO $\cdot$ ). Each of these radicals can abstract a hydrogen atom from the polymer backbone to form yet more carbon radicals. Each time additional free radicals are generated. Two free radicals can combine to terminate each other, which results in new crosslinks. Polymers with many double bonds provide many attachment sites for polymer radicals, leading to many crosslinks. These polymers become stiff and brittle consequently.

Other polymers undergo reversion or chain scission during ageing. Scission is favoured in polymers that are branched or have many side groups. During ageing alkoxy or carbon radicals are generated which undergo beta scission or unimolecular cleavage to lower molecular weights. These polymers degrade by becoming soft and tacky.

The exposure of rubber products to elevated temperature during the service life will result in gradual degradation of the product so that ultimately it may no longer fulfill its function. The rate at which this degradation takes place will be greatly accelerated under aerobic conditions, heat acting as catalyst for the oxidation process (167).

Various ageing processes are

**a. Oxidative ageing** – Oxidation of rubber vulcanizates is technologically important since the absorption of only a small amount of oxygen (1%) by rubber vulcanizates results in considerable change in physical properties. Natural and synthetic rubbers are attacked by oxygen and the reaction is accelerated by heat, light and the presence of certain metallic impurities which catalyze the decomposition of peroxides to form free radicals.

**b. Accelerated oxidation in the presence of heavy metal compounds**

Many heavy metal compounds, like copper and manganese have a catalytic action on the oxidation of rubber vulcanizates. Even traces of (0.001 wt %) copper and manganese compounds are able to accelerate the oxidation of rubber vulcanizates

**c. Heat ageing in the absence of oxygen**

Various reactions can take place in the absence of oxygen- thermal decomposition of crosslinks, continuation of inter or intramolecular network or shifting of crosslinks without change in the total numbers

**d. Fatigue**

When rubber is subjected to prolonged mechanical stress changes, cracks will slowly develop in the material and they grow until they lead to complete breakage of the article. Higher temperature and higher frequency of stress change accelerate crack formation.

**e. Ozone crack formation**

When vulcanizates are exposed to weather conditions in a static extended mode, cracks appear perpendicular to the direction of the applied stress. Small amounts of ozone in the atmosphere are the cause. Without extension of the

vulcanizates cracks are not formed. A critical extension has to be exceeded in any case before cracks show up. With increasing extension, the number of cracks formed per unit area and time increases rapidly. The speed of ozone crack formation depends on temperature and humidity of air. Totally saturated elastomers are ozone resistant.

**f. Crazeing effect**

When an unstressed vulcanizate is exposed to weather, especially prolonged sunlight, unoriented cracks can develop on the surface. The surface can, after prolonged irradiation become brittle.

**g. Frosting phenomena**

Frosting is caused by the action of warm, moist, ozone containing atmosphere on vulcanizates.

**1.3.2 Phenolic age resistors**

Age resistors react with the agents oxygen, ozone, light, weather and radiation which are responsible for the deterioration process. This in turn prevents or slows the polymer breakdown, improves the ageing qualities and extends the service life of the product involved (168).

Phenolic resin can give thermally stable crosslinks. The service life of sulphur cured vulcanizates can be improved by using PF resins. In the case of certain rubbers like IIR, NBR and SBR phenolic resin leads to crosslinking of the rubber and this improves the ageing behaviour. CNSL based resins are prospective candidates for this modifying action on rubbers. Retention of tensile modulus, tensile strength and elongation at break of natural rubber vulcanizates containing phosphorylated CNSL (PCNSL), 2-ethyl hexyl diphenyl phosphate and aromatic oil after ageing has been investigated (169,170). The vulcanizates containing PCNSL showed good retention of tensile properties after ageing due to the post-curing reactions during the ageing period (171). The effect of addition of paraffin oil, vegetable oil, castor oil and CNSL to natural rubber compounds has been compared in terms of the mechanical properties (172). Polymerized CNSL has been recommended as a substitute for DOP, DBP for nitrile rubber and neoprene rubbers (173). CNSL- phenol- formaldehyde resin when incorporated into rubber

articles improves resistance towards cracking and action of ozone (174). Sulphur vulcanized NR containing CNSL possesses greater resistance towards oxidation (175). The formation of a network bound antioxidant (78) or the formation of phenolic sulfides in situ during the vulcanization (79) have been used to explain the antioxidant activity of CNSL derivatives in natural rubber vulcanizates. The steric effect due to long tail substituents, has been also reported as an important factor (50). The alkyl substituents could trap both alkyl and peroxy radicals and increase antioxidant activity (80). CNSL condensed with formaldehyde has been recommended as an effective antioxidant for SBR (176). Cardanol is used as vulcanizing agent for IIR (177). Modification of NR with 10-15 phr of PCNSL resulted in improvement in tensile properties along with a lower degree of stress relaxation at high shear ratios and strain levels (178). Bromo derivatives of PCNSL improved the flame retardant characteristics of NR vulcanizates (179). Rheological studies on blends of NR and PCNSL indicates the plasticizing effect of PCNSL and good compatibility between NR and PCNSL (180). PCNSL lowers the activation energy of vulcanization of NR (181).

In this study, CNSL is used in the resin form as well as naturally occurring oil for modifying the ageing properties of various elastomers.

### 1.3.3 Other age resistors

#### a. Antioxidants

Antioxidants are substances that retard oxidation by atmospheric oxygen at moderate temperatures. Oxidation by atmospheric oxygen is a free radical chain reaction and can be inhibited at initiation and propagation steps.

All commercial important antioxidants fall into four classes (182) - amines, phenols, metal salt of dithioacids and bound antioxidants.

1. **Amine antioxidants** are strong protective agents but discolour and stain to various degrees. Examples are diphenylamine, naphthylamine, alkyldiamine, quinoline, phenylenediamine etc.
2. **Phenol** is less discolouring than amines. Most of the commercial antioxidants are of this type. eg. styrenated phenol, 2,2,4 – trimethyl-1,2-dihydroquinoline. In high temperature applications, polynuclear phenols generally are preferred over monophenols because of their lower sublimation rates.



3. **Metal salts of dithioacids** act as hydroperoxide decomposers and propagation inhibitors and are used in conjunction with other antioxidants, particularly phenols for rubber, petroleum products and plastics.
4. **Bound antioxidants** are copolymerized into the elastomer chain. The main advantage of such a system is low antioxidant extractability in applications where the elastomer is in contact with solvents capable of extracting conventional antioxidants.

According to their mode of action antioxidants are classified as primary or chain breaking and secondary or preventive antioxidants

1. **Chain breaking antioxidants** interfere with the chain propagation steps of polymer degradation. These antioxidants terminate the chain by
  - i. **Free radical traps** which interact with chain propagating  $\text{RO}_2$  radicals to form inactive products. Quinones and conjugated molecules can function as free radical traps.
  - ii. **Electron donors** give electron to peroxy radical thus stabilizing the system
- iii. **Hydrogen donors** are the most commonly used chain terminating antioxidants. Inhibitors of aromatic amine type interfere with oxidative chain propagation by competing with the polymer for peroxy radicals.

#### 2. Preventive antioxidants

- i. **Light absorbers:** Ageing induced by light can be prevented by using photostabilizers like hydrobenzophenone derivatives, benzotriazole derivatives, metal complexes of different metals etc.
- ii. **Metal deactivators:** These are strong metal ion complexing agents that inhibit catalyzed initiation. eg. Ethylene diamine tetra acetic acid.
- iii. **Peroxide decomposers:** These reduce hydroperoxides to alcohols without substantial formation of free radicals. eg. zinc dialkyl dithiophosphates.

Most conventional antioxidants trap the peroxy radicals or decompose the hydroperoxide. Amines and phenols are radical traps for peroxy and alkoxy radicals. Phosphites are peroxide decomposing antioxidants.

**b. Antiozonants**

Atmospheric ozone degrades polydiene rubbers by reacting directly with polymer main unsaturation. The most effective compound for ozone protection under static and dynamic stress are nitrogen substituted p-phenylenediamines. They increase the critical energy necessary to form ozone cracks. Therefore crack formation will start at higher extension and crack growth rate will be reduced.

**c. Ageing protection against hydrolysis**

Elastomers containing hydrolysable groups in the rubber matrix or in the side chain can be degraded by moisture. Ageing protectors for such rubbers should react with steam and moisture faster than rubber eg. carboimides

**d. Ageing protectors against crazing**

Ageing protectors used against crazing are alkylated phenols. The quantities used lie between 0.5 – 2 phr.

**e. Ageing protectors against frosting**

The best protection against frosting is obtained by proper choice of fillers and vulcanization accelerators. To some extent p, p' diaminediphenyl methane acts against frosting.

**f. Ageing protectors against fatigue**

The most effective fatigue protectors are aryl/alkyl-substituted p-phenylenediamines

**g. Ageing protectors against rubber poison**

The protection of rubber vulcanizates against Cu and Mn depends on a complex formation of the damaging ion. Ethylene diamine tetraacetic acid can act as copper protector.

**h. Ageing protectors against heat ageing**

For the selection of ageing protectors for heat resistant vulcanizates their volatility is important. The volatility depends strongly on the molecular structure. The least volatile protective agent yields the highest high temperature resistance.

#### **1.4 POLYMER WOOD COMPOSITES FROM CNSL.**

Composite wood products may be produced using wood fibers, flakes, chips or shavings or veneers. During the manufacturing process these materials are often combined with different glues, resins, water repellents and preservatives to produce sheet boards. Addition of CNSL increases the heat resistance of phenolic molding compositions (183). Major composite wood products include (1) particleboard (from wood flakes, shavings or splinters) (2) fiberboard (from fibers of wood) (3) plywood (from one or more veneers) (184).

Acid catalyzed CNSL –formaldehyde resins cured with  $\text{CuCl}_2$  have been used as adhesives in the manufacture of particleboard (185). Alkali catalyzed CNSL- formaldehyde resins have been recommended as bonding materials for the preparation of particleboard (186). Composite panel showing excellent ablation characteristics were developed from CNSL (187). Properties of particleboards from hemp fibre and CNSL (188) and coffee husk and CNSL (189) have been reported. Particleboard were prepared from rice husk by mixing them with resin prepared by the condensation of CNSL with formaldehyde and an alkaline catalyst (190). Medium density fiberboards have been moulded comprising coir fibre, CNSL and formaldehyde (191, 192). Jute reinforced composite laminate have been manufactured by soaking jute in a CNSL- modified formaldehyde phenol copolymer and pressing together several layers of the soaked jute (193). Fire resistant coconut pith sheets for use as building materials have been prepared by mixing coconut pith and adhesives prepared by copolymerising CNSL with orthophosphoric acid and neutralizing the polymer before mixing it with formaldehyde and HMTA (194). Mechanical and thermal properties of boards made with kenaf fibers and CNSL have been investigated (195). Central Building Research Institute (CBRI), Roorke, India has developed medium density composite doors containing coir fiber, CNSL and paraformaldehyde (196). A novel resin has been developed by the Centre for Advanced and Renewable Materials, Bangor, Wales based on CNSL primarily for use in particleboard (197)

### 1.4.1 Particleboard

Wood waste of the wood working industry induced the idea of particleboards. The story of the growth of the particleboard industry may be found in the review article by Klauditz (198). Particleboards are made from almost any form of wood residue except bark.

#### a. Wood fillers - *different forms*

1. ***Cut flakes*** – These are prepared by slicing wood into flat thin particles in which the grain direction of wood lies in the plane of the particle. With this type of particles high length to thickness ratio can be developed. Such particles orient very well in the plane of the board, so that maximum bending strength and dimensional stability can be achieved.
2. ***Planar shavings***- Planar shavings tend to have undesirably high bulk because of their curled nature, and to reduce their bulk, the shavings may be passed through a mechanical reduction treatment to split them and eliminate curl. Compared to flakes, shavings have a lower net length to thickness ratio. Planar shaving boards tend to develop higher strength in the direction perpendicular to the plane of the board. A detailed study of the use of planar shavings in particleboard has been made by Heebink et al. (199).
3. ***Splinter*** – Splinter is produced from solid wood residue by human milling. Splinter is produced without any cutting action. Instead the wood is broken down by a hammering or smashing action. This breakdown process tends to produce comparatively blunt particles in which length to thickness ratio of the particles is still less favorable than is obtained from pure planar shavings. The actual shape of the particle depends on the species used and moisture content (200)
4. ***Sawdust*** – Sawdust represents a still lower grade of wood residue. The work by Klauditz and Buro (201) explores the use of sawdust in particleboard as a mixture with high quality flakes.
5. ***Bark and sander dust*** – These materials are wood residues of the lowest value. Bark does not have the oriented fiber structure of wood and therefore has low strength. Sander dust appears as a residue from a plywood operation, and in greater quantities from a particleboard mill.

## **b. Ingredients of particleboard**

### ***1. Adhesives***

**i. Thermoset binders**– Commonly used thermoset adhesives include phenol formaldehyde, urea formaldehyde and melamine formaldehyde.

a) ***Phenol formaldehyde*** – PF is available as powdered resin and as liquid resin. Liquid resin is a water dilutable aqueous resin containing small amounts of caustic soda. Powdered phenolic resin has one particular process advantage in boards made from flakes. These long flakes do not fluidize readily. Powdered resin mechanically mixed with the flakes tends to distribute uniformly over the particles. The performance of the synthetic resins as particleboard binders has been studied by Carroll (202). The efficiency of these resins depends on the proportion of the resin binder and the moisture content of the wood. Excess moisture content tends to plasticize the resin and can also retard the cure of the resin. CNSL based resin can be used in the present context as the adhesive.

b) ***Urea formaldehyde*** – The major virtues of UF resin are low cost, rapid cure, process convenience and clear colour. The resin is commonly supplied in the form of an aqueous resin solution containing 60-65% solids and with viscosity in the range of 200-500 cp. It is also available in powdered form which can be reconstituted to an aqueous solution, a form that is more suitable for shipment to isolated board plants.

Two main objections to UF resin now used are its tendency to release formaldehyde fumes when the finished board is exposed to heat and humidity and the lack of complete durability of the resin especially towards moisture (203). If the durability of the particleboard is inadequate for an intended application UF resin may be modified by addition of resorcinol-formaldehyde or MF resin

c) ***Melamine formaldehyde*** – MF resins are used primarily for decorative laminates, paper treating and paper coating. They are more expensive than PF resins. MF resins may be blended with UF resins for certain applications.

## **ii. Proteinaceous and thermoplastic binders**

Other binders used in particleboard manufacture are proteinaceous adhesives and thermoplastic adhesives. Proteinaceous adhesives have high inherent viscosity which is unsuited for spray application and their water resistance is generally poor. eg. Soybean glue, caseine glue.

Inorganic binders used are portland cement, magnesite cement and gypsum. The finished product is low in bending strength, high in compressive strength and is resistant to fire and insect attack.

## **2. Additives**

Particleboard retains many of the properties of wood from which it is made. For most applications, the properties of these boards are adequate. For special applications, the properties of the boards may be modified by the addition of chemical agents to provide additional properties such as water repellence, fire resistance and resistance to decay or insect attack.

- i. **Paraffin wax** – Paraffin wax imparts water repellency to board (204). The amount of wax used is 1-1.5% referred to dried wood. A higher percentage reduces binder wetting and adhesive strength (205).
- ii. **Fungicides and insecticides** – For a few applications of particleboard, wood does not have sufficient resistance to attack by fungi and insects. Resistance to fungi can be improved by the addition of pentachlorophenol in amounts not more than 1-2% of the wood (206). Tri butyl tin oxide or fluorine compounds in quantities up to 1.5% are also used (207).
- iii. **Flame retardants** – The requirements of flame retardance can be met by adding flame retardant materials. Ammonium hydrogen phosphate and ammonium polyphosphate are preferred. They may be used in combination with halogen compounds. The addition of inorganic substance like vermiculate or perlite has been recommended but board strength is reduced.

**c. Properties and uses of particleboard**

Table 1.7 shows the requirements for different grades of particleboard as specified by American National Standards for particleboard ANSI A208.1 (NPA 1993)(208).

**Table 1.7**  
**Particleboard grade requirements**

| Grade | Internal bond<br>(MPa) | MOR<br>(MPa) | MOE<br>(MPa) |
|-------|------------------------|--------------|--------------|
| H-1   | 0.9                    | 16.5         | 2400         |
| H-2   | 0.9                    | 20.5         | 2400         |
| H-3   | 1                      | 23.5         | 2750         |
| M-1   | 0.4                    | 11           | 1725         |
| M-S   | 0.4                    | 12.5         | 1900         |
| M-2   | 0.45                   | 14.5         | 2225         |
| M-3   | 0.55                   | 16.5         | 2750         |
| LD-1  | 0.1                    | 3            | 550          |
| LD-2  | 0.15                   | 5            | 1025         |

H= density > 800 kg/m<sup>3</sup>, M=density 640 to 800 kg/m<sup>3</sup>, LD= density <640 kg/m<sup>3</sup>  
M-S refers to medium density; special grade added to standard grades M-1, M-2 and M-3. Grade M-S falls between M-1 and M-2 in physical properties.

Table 1.8 shows the requirements for different grades of particleboard as per IS 3087-1985

**Table 1.8**  
**Physical and mechanical properties of flat pressed single**  
**layer particleboard (IS 3087-1985)**

| Properties  |                           |
|---|---------------------------|
| <b>Density</b>  | 500-900 Kg/m <sup>3</sup> |
| <b>Moisture content</b>   | 5- 15%                    |
| <b>Water absorption</b><br>(24h soaking)                                      | 50%                       |
| <b>MOR</b>  | 11 N/mm <sup>2</sup>      |
| <b>Tensile strength</b> (perpendicular to surface)<br>(Up to 20 mm thickness) | 0.8 N/mm <sup>2</sup>     |

Particleboard is used for furniture cores and as underlayment.

#### 1.4.2 Plywood

In general, plywood is a material made of at least three layers of wood, mostly veneers, with application of adhesives, pressure and heat (209). Plywood is generally classified into interior and exterior grades.

Exterior type plywood will retain its glue bond when repeatedly wetted and dried or otherwise subjected to weather and is intended for permanent exposure. Within each type there are a number of panel grades based on the quality of veneers and the panel construction.

##### a. Ingredients of plywood

Non modified resols catalyzed by NaOH are used for weather resistant plywood. In order to adjust wetting and avoid excessive penetration and to obtain a uniform joint thickness, diluents and fillers are almost always used. Rye or wheat flour can be used for interior grades and non-swelling fillers like coconut shell flour for exterior grades. Apart from cost reduction the brittleness of the adhesive joint is reduced by these additives.

##### b. Properties and uses of plywood

Plywood has high strength- to- weight ratio and strength – to-thickness ratios. It has excellent dimensional stability along its length and across its width and minimal



edge swelling. Plywoods are used as roof sheathing, subflooring and numerous applications in panelling and furniture apart from countless industrial applications.

### **1.4.3 Fiberboard**

Fiberboard includes hardboard, medium density fiberboard and insulation board. Because wood is fibrous by nature, fiberboard exploits the inherent strength of wood to a greater extent than does particleboard. To make fibers, bonds between the wood fibers must be broken by attrition milling. This can be accelerated by water soaking, steam heating or chemical treatments. A number of classifications of fiberboards can be given according to the appearance, method of production, kind of application and specific gravity (210)

#### **a. Ingredients of fiberboard**

Only wood of inferior quality and industrial wood is used for the production of fibers. The bark is not completely removed because its presence up to 15% does not affect the properties of fiberboard substantially. Sawdust can also be added upto 30%. In general, fiberboards can be produced without bonding agents, using only the bonding ability of the fiber. In order to improve mechanical properties and to reduce water absorption and swelling, phenolic resins are used as bonding agents. Urea resins are also used. Urea resins are used for boards which are not subjected to high humidity.

Dry resin content for boards is 1-3% calculated on dry fiber weight. The PF resin is precipitated out of a diluted aqueous solution by acidic chemicals like diluted sulphuric acid or aluminium sulphate and fixed to the fiber. Hydrophobic agents like wax and paraffin reduce water absorption and swelling. The amount of wax is normally within the range of 1% based on the weight of the dry fiber. Furthermore, flame retardants, fungicides and insecticides, release agents and other improving materials like drying oils can be added.

#### **b. Properties and uses of fiberboard**

The most familiar application is acoustical tile. In building construction, insulation board panels find use as boards for poured- in- place concrete, rigid roof insulation for built up roofs, and low cost single backing.

Medium density panels have found acceptance as siding. Sound transmission from one room to another is reduced through the use of insulation board products.

Medium density board is used in place of solid wood in many furniture applications (211)

Hardboard is widely used in building construction for paneling, siding, decking and in manufactured products such as garage doors. In automobiles it has been used for door panels, for a package shelf, and for interior roof linings

### **1.5. CNSL BASED PHENOLIC RESIN**

By virtue of its phenolic nature CNSL can be condensed with formaldehyde to give PF type resins. Phenolic resin discussed in the earlier section can be prepared starting from CNSL by similar methods. Reactions of CNSL are discussed in Section 1.1.5 and preparation of CNSL based resins in Section 2.3. The long chains in CNSL impart flexibility due to internal plasticizing, resulting in the formation of soft resins at elevated temperature unlike phenol- formaldehyde resins which are hard (212).

### **1.6 SCOPE AND OBJECTIVES OF THE WORK**

CNSL can be polymerized in a variety of ways: addition polymerisation through the side chain double bonds, condensation polymerisation through the phenolic ring, oxidation polymerisation etc. Several modifications are possible due to its special structural features. CNSL is cheap, renewable and underutilized. It can replace phenol in many applications. Greater utilization of CNSL as a monomer for industrial polymer products can be an attractive proposal in view of its low cost, abundant availability and chemically reactive nature. By using CNSL in place of phenol, phenol derived from petrochemicals can be conserved and a cheap agro-byproduct can be utilized.

The overall objective of the study is to develop new applications for CNSL in the polymer field.

Specific objectives of the work can be stated as follows

1. To synthesize CNSL-phenol-hexa resin and study the effect of varying parameters phenol: formaldehyde and CNSL: phenol ratios on the properties of the synthesized resin.

## *Chapter 1*

---

2. To study the adhesive properties of blends of neoprene and CNSL based resin for bonding metal-to-metal, metal- to- rubber and rubber- to- rubber.
3. To study the effect of synthesized CNSL based resin as age resistor for the elastomers NBR, SBR, CR, IIR, EPDM and NR.
4. To develop particleboard from wood waste and CNSL based resin

**REFERENCES**

1. M.T. Harvey and C. Caplan, *Ind.Eng.Chem.*, 32 (10), 1306 (1940)
2. S.Manjula, J.D.Sudha, S.C.Bera and C.K.S.Pillai, *J.Appl.Polym.Sci.*, 30,1767 (1985)
3. *Economic Review* (2004).
4. G.Stadeler, *Ann. Chem. Pharm.*, 63,137-164 (1847)
5. A.R.R. Menon, C.K.S. Pillai, J.D.Sudha and A.G.Mathew, *J.Sci.Ind.Res.*, 44, 324 (1985)
6. P.H.Gedam and P.S.Sampathkumaran, *Prog.Org.Coat.*, 14, 115 (1986)
7. J.H.P.Tyman, *Chem.Soc.Rev.*, 8, 499-537 (1973)
8. J.H.P.Tyman, D.Wielezynski and M.A.Kashani, *J.Am.Chem.Soc.*, 55, 663 (1978)
9. P.A. Mahanwar and D.Kale, *Indian J. Technol.*, 3, 191-193 (1996)
10. V.Paul and L.M.Yeddanapally, *Nature*, 174, 604 (1954)
11. W.F.Symes and C.R.Dawson, *Nature*, 171,841 (1953)
12. J.A. Cornelius, *Trop.Sci.*, 8(2), 79 (1966)
13. Indian patent 78612, Sep 25 (1961).
14. S. Siddiqui and A.A. Khan, *Indian Patent* 32237 (1945)
15. J.H.P.Tyman, *J.Am.Oil.Chem.Soc.*, 66 (4), 533-537 (1989)
16. R.L.Smith Jr, R.M.Malaluan, W.B. Sctianto, H.Inomala and K.Arai, *Bioresource Technology*, 88, 1-7 (2003)
17. R.K.Jain and K.Sivala, *J.Food Engg.*, 32 (2), 339-345 (1997)
18. M.T.Harvey and S. Caplan, *Indusrial and Engineering Chemistry*, 33, 10, 1306-1310 (1940).
19. L.C.Anand, *J.Petro Chem.*, 12 (5), 3 (1981)
20. H.T. Harvey, *U.S Patent* 2434797 (1948)
21. V. Madusudhan, M.Sundaramaiah and N.B.Naidu, *Indian J.Tech.*, 11, 347 (1973)
22. H.Barron, *Use of CNSL resin in modern plastics*, 2<sup>nd</sup> edn, P 84, Chapman and Hall, London (1949)
23. R.Antony, C.K.S.Pillai and K.J. Scariah, *J.Appl.Polym.Sci.*,41, 1765 (1990).
24. N.R.Krishnaswamy and K.P.Govindan, *Chem.Ind.*, 1892 (1958)

## Chapter 1

---

25. I.N.Hemaletha, H.Dakshinamurthy and S. Aggarwal, *Paint Manufa.*, 39 (11), 41 (1969)
26. D.S.Basu and A.K.Kar *Chem.Age India*, 24 (6), 341 (1973)
27. M.K. Misra and G.N.Pandey, *J.Appl. Poymer Sci.*, 30, 969-977 (1985)
28. D.O' Conner and F.D Blum, *J.Appl.Polym.Sci.*, 33, 1933-1941 (1987)
29. K.Sathialekshmi, *Bull. Materi. Sci.*,16, 137 (1993)
30. S.Lenka, A.P.Das and P.L.Nayak, *J.Polym.Sci.Polymer Chem.*, 30,4619 (1985)
31. J.S.Aggarwal, *Paint manuf.*, 36, 29 (1966)
32. M.T.Mortimer, *Cashew News*, 11,16 (1977)
33. K.K.Alva, Shridara, *J.Macromol.Sci.*, A 34(4), 665-674 (1997)
34. S.Caplan US Patent 216059 (1940)
35. M.T.Harvey, U.S. patent 2324300 (1943)
36. Harvel Corporation Bp 627927 (1949)
37. C.R. Dawson and D. Wasserman, US Patent, 2502436 (1950)
38. C.R. Dawson and D. Wasserman, US Patent, 2502708 (1950)
39. Harvel Corporation BP 625497 (1949)
40. S. Captain and D.E. Rosamila U.S. patent 2476692 (1949)
41. H.F. Haufman and J. Eerve. *Fette. Sieten Anstridu* 69(8), 577-582 (1967).
42. H.M. Shivadasami BP 1279257 (19720)
43. Y.K. Kamath, S.V. Puntumbekkar and D.B. Vidwans, *Paintindia*, 14, 4, 21 (1964).
44. A.R.R.Menon, C.K.S.Pillai and G.B.Nando, *J.Adhes.Sci.Tech.*, 9, 443-451 (1995)
45. A.R.R. Menon, *Rubber Rep.* 15 (4), 149 (1990)
46. A.R.R.Menon, C.K.S.Pillai and G.B.Nando, *Kauts. Gummi. Kunsts.*, 45 (9), 708 (1992)
47. A.R.R.Menon, C.K.S.Pillai and G.B.Nando, *Polym. Degrad. Stab.*, 52(3), 265 (1996)
48. A.R.R.Menon, C.K.S.Pillai and G.B.Nando, *Journal of Applied Polymer Science* 51 (13), 2157 (1994)
49. C.K.S.Pillai , V.S. Prasad, S.C. Bera and A.R.R.Menon *Journal of Applied Polymer Science* 41, 2487 (1990)

50. V.S. Prasad and C.K.S. Pillai, *Journal of Applied Polymer Science*, 27, 2631 (2006)
51. H.P. Bhunia, R.N. Jana, A. Basali, S. Lenka, G.B. Nando, *J. of Polymer Science Part A Polymer Chemistry*, 36, 391-400 (1998).
52. N.D.Ghatge and U.S.Patil, *Angew.Makromol.Chem.*,19, 83 (1971); S.S. Mahajan, *Indian J.Technology*, 22(11), 439-40 (1984)
53. C.R.Dawson and D. Wasserman U.S. Patent 3496151 (1959)
54. Minn.Mining and Mfg. Co., BP 1043346 (1960)
55. D.A.Rahul, *Paintindia*, 40(8), 59-60 (1990)
56. L.C.Anand, *Paintindia*, 28(6), 13-33 (1978)
57. A.Orazo, *Chem.Ind.*, 61(10), 718-726 (1979)
58. A.Orazo, *Chem.Ind.*, 78(6), 693-696 (1996)
59. J.S.Aggarwal, *J.Colour Sci.*,14(3),1-9 (1975); 15(1), 14-25 (1976)
60. S.Ramanujam, *Paintindia*, 10, 91-106 (1960)
61. J.S.Aggarwal, *Paintindia*, 17(1), 103-112 (1967)
62. A.E.Oats, *Ind.Chem.*, 323 (1965)
63. M.Sundaramaiah, *Fette Seifen Anstriokn* 78, 472 (1976)
64. S.P.Potnis and J.S.Aggarwal, *J.Colour Sci.*, 13 (1), 10-12 (1974)
65. N.D.Ghatge and N.N. Maldar,, *Rubber Chem. Technol* 52 (2), 353 (1979)
66. N.D.Ghatge and B.M. Shinde, *Elastomerics*, 11 (12), 48 (1972)
67. N.D.Ghatge and B.M. Shinde, *Rubber Chem. Technol.* 53, 239 (1980)
68. N.D.Ghatge and R.G. Gokhale, *Rubber Age*, 101, 52 (1969)
69. N.D.Ghatge and R.G.Gokhale, *Indian J. Tech.*, 9(10), 391 (1971)
70. N.D.Ghatge and R.G.Gokhale, *Rubber India*, 13, 2406 (1972)
71. C.R. Dawson and D. Wasserman, *J.Amer.Chem.Soc.*, 72, 4994 (1950)
72. S.C.Sethi and B.C.S Rao, *Indian J.Tech.*, 2, 206 (1964)
73. M.S.Bhatnagar, *Pop.Plastics*, 79 (1982)
74. D.Narayanamurthy, *Res.Ind.*, 13(3), 134-136 (1968)
75. J.S.Aggarwal, *Paint Manuf.*, 43 93), 29-31 (1973)
76. L.C. Anand, *Popular plastics* 15-35 (1978).

## Chapter 1

---

77. L.C. Anand, *Paintindia*, 13-33 (1978)
78. R.A. Rajapakse, W.A.S. Gunasena and K.B. Wijikoon, *Polymer* 19, 205 (1978)
79. R.A. Rajapakse, K. Anandakumaran, W.A.S. Gunasena and K.B. Wijekon, *Polymer* 20, 887, 1979
80. F.H.A. Rodrigues, J.P.A. Feitose, N. M. P.S. Ricardo,, F.C.F. Franca and J.P.B.. Carioca, *J. Braz. Chem. Soc.* 17(2),, 265-271 (2006)
81. M.T.S. Trevisan, B. Pfundstein,, R. Haubner, G. Wurfele, B. Spiegelhaldir, H. Bartsch and R.W. owen, *Food and Chemical Toxicology* 44 (2),, 188-197 (2006)
82. Y. Koizumi,, *Jpn Kokai tokkyo Koho JP 03217484* (1991)
83. <http://www.adarshsanoor.com/cnsl>, January 2001
84. <http://www.cshewindia.org/html/c0310com.htm> downloaded on 5/3/2005
85. *Jpn. Kokai Tokkyo Koho JP 0948967* (1997)
86. *Jpn. Kokai Tokkyo Koho JP 09221658* (1997)
87. S. Takahata *JP 09157633* (1997)
88. M. Suzuki *JP 04363384* (1992)
89. *Jpn. Kokai Tokkyo Koho JP 0931213* (1997)
90. Hitachi Chemical Co. Ltd *JP6040833* (1983)
91. Hitachi Chemical Co. Ltd *JP5877934* (1982); *JP 5881236* (1983)
92. M. Kikuchi, *Jpn. Kokai Tokkyo Koho JP 2709136972* (1997)
93. *Jpn. Kokai Tokkyo Koho JP 09286976* (1996)
94. *Jpn. Kokai Tokkyo Koho JP 0948967* (1997)
95. *Jpn. Kokai Tokkyo Koho JP 0849740* (1997)
96. K. Sakanoto and Y. Suzuki, *Jpn. Kokai Tokkyo Koho JP 09132769* (1997)
97. T. Hayash, *Jpn. Kokai Tokkyo Koho JP 0931213* (1997)
98. H. Usuil, M. Seko and S. Hiranosa *Jpn. Kokai Tokkyo Koho JP 09111007* (1997)
99. F.D. Blum, *J. Am. Chem. Soc.*, 37, A1 (1996); F.D. Blum, *Poly. Prepr.*, 37, 733-734 (1996)
100. S.C. Bera and C.K.S. Pillai, *Indian J. Tech.*, 27 (8), 343-347 (1989)

101. S.Ramanujam, *Paintindia*, 11 (1), 47-112 (1961)
102. A.K.G.Pillai IP 158294(1983)
103. Patent No.636/DEL/96 dated 27<sup>th</sup> March 1996, India
104. V.Madusudhan, B.G.K. Murthy and M.A.Sivasamban, *Cashew Couserie* 6(2), 12-16 (1984)
105. S.K.Swan, S.Sahoo, D.K.Mohapatra, B.K.Mishra, S.Lenka, P.L.Mayak, *J.Appl. Polymer Sci.*, 1413, 54 (1994).
106. O.Akaranta, A.O. Aloko, *Pigment and Resin Tech.*, 28(6), 336-340 (1999)
107. H.P.Bhunia, G.B.Nando, S.Lenka, P.L.Nayak, *Eur. Polym. J.*, 35,1713 (1999).
108. A.R.R.Menon, A.L.Aigbodion, C.K.S.Pillai, N.M.Mathew, S.S.Bhagawan, *Polym. J.*, 38, 163 (2002).
109. H.Oyabu, T.Asami, O.Yamamoto, H.Tajima, *J.Jpn. Soc. Colour Mater.*, 65, 349 (1992).
110. H.Oyabu, T.Asami, M.terada, Y.Aso, Y.Oda, *J Jpn. Soc. Colour Mater.*, 65, 469 (1992)
111. Kumanotani, *J.Prog.Org.Coat.*, 26, 163 (1995)
112. N. Niimura, T.Miyakoshi, J.Onodera, T.Higuchi, *J.Anal. Appl. Pyrol.*, 37, 199 (1996)
113. Kumanotani, *J Prog. Org. Coat.*, 34, 135 (1997)
114. E.Obataya, K.Umemura, M.Norimoto, Y.Ohno, *J.Appl. Polym. Sci.*, 73, 1727 (1999)
115. J.Hong, H.K. Kim, J.O.Choi, *J Appl. Polym. Sci.*, 76, 1804 (2000).
116. M.M. Shirsalkar and M.A. Swasamban, *Corros.. Paint*, 2, 203 (1979)
117. M.M. Shirsalkar and M.A. Swasamban, *Corros. Control seminar Proc.*1976, Natl. Prod. Council, New Delhi (publ. 1977) p.329
118. M.T.Harvey, *Cashew News Bull.*,11, 5-8 (1978)
119. D.N.Batia, N.J.Kazi and A.Asak. *Foundry J.*, 21(6), 10-15 (1975)
120. B. Banargee, N.P.Suryanarayana and C.S. Inamadar, *Indian Patent* 142572 (1977)
121. A.Mahanwar and P.D.Kale, *J.Appl.Polym.Sci.*, 61 912), 2107-2111 (1996)
122. H.Masaki, *J.Aagri. Food Chem.*, 39(2), 418-421 (1991)



123. J.K. Jain, J.Narayan., Timber Div. Associ. India, 37(2), 25-27 (1991); J.K. Jain, J.Narayan., Timber Div. Associ. India, 37(4), 29-36 (1991)
124. N.P.Suryanarayana and K.M. Joshy, J. Appl.Polym.Sci., 8(3), 1491(1964)
125. K.D.Pathak, Indian J.Tech., 1(11), 433-34 (1963)
126. E.H.G. Seargent, British Patent 678019 (1952)
127. Zhisheng Dai, Anton Constantiniscu, Adarsh Dalal and Chris Ford, Cardolite Corporation, New Jercey.
128. O.O. Ilomos, Y.M. Makame, L.L. Mkyala, Bulletin of the Chemical Society of Ethiopia, 18(1), 81-90 (2004)
129. S.K.S. Parashar, D.K. Basu, M. Banarjee, Journal of Metallurgy and Material Science, 45(2), 97-101 (2003)
130. J.Lin, Tianra Chanwu Yanjiu Yu Kaif ,14(6), 24-26 (2002)
131. A.O.Attanasi, P.Filippone, Fuel, 83 (14-15), 2099-2100 (2004)
132. A.O.Attanasi, C.V. D`Ornellar, L.R. Queirinz, Fuel, 82(12), 1465-1469(2003)
133. D.Ras, P.K.Basu, P.Raghunathan , Journal of Applied Polymer Science, 89 (7), 1959-1965 (2003)
134. A.C. Govindan, Chem.Engg.World, 32(1), 79-80 (1997)
135. R.Ikeda, M.Tanaka, H.Uyana, S.Kobayashi, Polymer, 43(12), 3475-3481(2002)
136. V.D. Athawale, N.J.Shetty, Surfac Coatings International, 83(4), 168-172) (2000)
137. T.C.Pathak, S.I.Agarwal and I.Masood, Materials and Structure, 25(150), 355-357 (1992)
138. R.D. Shingle, P.P. Wadgaonkar, US Patent 6790993 (2003)
139. G.G. Fernandes, Journal of Applied Polymer Science, 73(1), 29-34 (1999)
140. P.B.Chakrawarti, V.Mehta, Indian Journal of Technology, 25(3), 109-113 (1987)
141. A.R.R. Menon, Journal of Fire Sciences, 15(1), 3-13 (1997)
142. D.V. Sudha, L.L. Mkyala, Journal of Scientific and Industrial Research, 38 (5-6), 186-191 (1995)

143. S.K.Sahoo, S.K. Swain, D.K. Mohapaha, S.Lenka, *Angewandte Makromolekulare Chemie*, 233, 1-13 (1992)
144. M.Selvaraj, S.Guruviah, *Bulletin of Electrochemistry*, 5(9), 681-684 (1989)
145. S. Muralikrishnan, P.Jayakrishnan, S.Guruviah, *Bulletin of Electrochemistry*, 5(9), 674-676 (1989)
146. Toshimi Shimizel, *AIST Today International Edition*, No.10, <http://www.aist.go.jp>
147. L.H.Sharpe, *The materials, Processes and Design Methods for Assembly with Adhesives Machine Design*, 38(19), 179-200 (1966)
148. E.M Petree, *Plastics and Adhesives, Handbook of Plastics and Elastomers*, Mc Graw- Hill (1975).
149. N.J. De Lollis, *Adhesives for Metals- Theory and Technology*, Industrial Press (1970)
150. I. Skiest, *Handbook of adhesives*, 2<sup>nd</sup> edition, Van Nostrand Reinhold Co. New York (1977).
151. N.J. De lollis, *Adhesives and Adherends*, Robert E. Krieger Publishing Co. Huntigton (1980)
152. E.J Bruno (ed), *Adhesives in modern manufacturing*, Society of Manufacturing Engineers (1970)
153. A.G.Bayer, *Baypren Chloroprinkaut Schuk*, Technical bulletin.
154. E.Schunck, *Kunsthartz-Nachrichten Hoechst*, 4, 33 (1973)
155. J.Shields, *Adhesive Handbook*, 2<sup>nd</sup> edition, Newnes-Butterworth, London (1976)
156. D.Narayanamurthy and R.S.Gupta, *Rheo Acta* 1, 514 (1961)
157. CNSL Patents, *Cashew export promotion council, Cochin Vol 1 & 2*, 1964, 1976
158. D.Narayanamurthy and N.C. Jain, *Forest Research Institute, Dehradun, Indian Forest Leaflet No. 111* (1947)
159. C.P. Dhamany, *Paintindia*, 19, 12 (1963)
160. C.P.Dhamany, *Paintindia*, 21(6), 17 (1971)
161. D. Narayanamurthy, T.R.N.Prasad and T.S. Rangaraju, *Res & Ind*, 13, 134 (1968)
162. D. Narayanamurthy and C.H. Pande, *Composite Wood*, 4(6), 97 (1957)

163. C.R. Bierman and J.D. Welks, US Patent 3879238 (1975)
164. H. Takagishi, M. Wakabayashi and Y.Takagi, F.Goto and E. Ohuno, Ger. Offen. 2923314 (1979)
165. S.A. Perry, Chem. Paint, 9, 188 (1946)
166. A.R.R. Menon and C.K.S. Pillai, J.Adhes. Sci. Tech. 9(4), 443-451 (1995)
167. R.W Dyson, Engineering Polymers, Chapman & Hall, New York (1983)
168. M Morton, Rubber technology, Chapman & Hall (1995)
169. A.R.R Menon, C.K.S Pillai and G.B. Nando, Eur. Polym.J., 34, 7, 923-929 (1998).
170. A.R.R Menon, C.K.S Pillai and G.B. Nando, J. of Applied Polymer Science, 73, 813-818 (1999).
171. A.R.R Menon, C.K.S Pillai, G.B Nando, Journal of Applied Polymer Science, 68, 1303-1311 (1998).
172. T.R Kukreja, R.C. Chanhnan, S.Choe, P.P Kundu, Journal of Applied Polymer Science, 87, 1574-78 (2003)
173. B. Banarge and C.S. Inamdas, Rubber India, 30(4), 13 (1978)
174. S.D. Shinkle, US Patent 2648613 (1953)
175. R.A. Rajapaske, W.A.S. Gunasena and K.B. Wijekoon, Polymer, 20, 887 (1978)
176. N.B. Fegade, Y.B. Sanghvi and W. Millns, Rubber India, 3391, 17 (1981)
177. N.D. Ghatge, B.M. Shindi, Elastomric 111(2),, 48-50 (1978)
178. A.R.R. Menon, J.of Applied Polymer Science 65(11), 2183-2189 (1997)
179. A.R.R.Menon, J. of Fire Sciences 15(1), 3-13 (1997)
180. A.R.R.Menon, C.K.S. Pillai, Polym.Sci 2,657-661(1994)
181. A.R.R. Menon, C.K.S. Pillai and G.B. Nando, Polymer 39(17), 4033-4036(1998)
182. J.M Martin, Handbook of Rubber Technology, Vol 1, CBS publishers and distributors, New Delhi.
183. S.D. Vernekar, Indian J.Tech., 18(4), 1894), 170-172 (1980)
184. Ency. of Polymer Science and Technology, Vol 4, Interscience publishers, John Wiley & sons, New York (1989)
185. C.P. Dhamany, Paintindia, 26, 19 (1979)

186. C.P. Dhamany and K.R. Singh, *Paintindia*, 29, 40 (1979)
187. C.K.S.Pillai, J.D.Sudha and A.G.Mathew, *Indian Patent* 314 (1987)
188. L.Y Mwaikambo, M.P Ansell, *Composites Science and Technology*, 63, 1297-1305 (2003)
189. E.T.N. Bisanda, W.O. Ogolu and J.V. Tesha, *Cement and Concrete Composites*, 25, 593-598 (2003).
190. G. Joseph, *Indian patent* 146015 (1979).
191. S.P. Agarwal, S.K. Dolui, *Res. Ind.*, 40 (1), 1-4 (1995).
192. S.P. Agarwal, S.K. Dolui, *Indian patent* 186986 (2001)
193. B.C. Mitra, A.P. Mandal, D. Soman, *Indian patent* 180002(1998)
194. T.Mathew, *Indian patent* 162132 (1988)
195. S.H. Aziz and M.P. ansell, *Composite Science and Technology* 64 (9), 1231-1238 (2004)
196. <http://www.fifac.org.in/news/build.May> 2002
197. <http://www.bc.bangor.ac.uk> May 2002
198. W. Klauditz, *Development, state and economic significance of particleboard manufacture*, *Holz-Roh-Werkstoff*, 20,1-12 (1962)
199. B.G Heebink, R.A Hann and H. Haskell, *Particleboard quality as affected by planar shaving geometry*, *Forest Prod J.*, 14, 486-94 (1964)
200. M Carroll, *Whole wood and mixed species as raw material for particleboards*, *Wash state Univ. Bull No* 274 (1963)
201. W Klauditz and A Buro, *The suitability of sawdust for the manufacture of particleboards*, *Holz-Roh- Werkstoff*, 20,19-26 (1962)
202. M Carrol, *Relative efficiency of UF and PF resins in particleboard*, *Forest Prod.J.*, 13, 113-120(1963)
203. O. Wittman, *The subsequent dissociation of formaldehyde from particleboard*, *Holz Roh Werkstoff*, 20,221-224 (1964)
204. J.Amthor, *Holz Als Roh and Werkstoff*, 30, 422 (1972)
205. L.Ranta , *Holz als Roh and Werkstoff*, 36, 37 (1978)
206. H.A. Huber, *Preservation of particleboard and hardboard with pentachlorophenol*, *Forest prod J.*, 12, 228-301 (1962)

## ***Chapter 1***

---

207. W.Metzner, H. Bollman , Holzschutz In: Ullmanns Encyclopadie D. Techn. Chem. Vol 12, Ed Weinheim, Verlag Chemie (1976)
208. American National Standard for Particleboard ANSI A. 208.1 (NPA 1993)
209. American Plywood Association, US product standard (1974).
210. Forest products laboratory, Wood Handbook: Wood as an engineering material, Agric. Handbook 72 (Rev.), U.S Department of Agriculture Washington D.C. (1987).
211. J.A. Youngquist, Reconstified and treated products, Proceedings, Canfor Symposium (1989).
212. M.V. Thanh, Eur. Polym. J., 285, 25 (3), (1989)

# Chapter 2

## **SYNTHESIS OF CNSL RESINS**

---

### 2.1 INTRODUCTION

### 2.2 QUALITY CONTROL TESTS FOR CNSL

- a. Specific gravity
- b. Insoluble matter
- c. Volatile matter
- d. Ash content
- e. Iodine value
- f. Polymerization time
- g. Viscosity
- h. Molecular weight

### 2.3 PREPARATION OF CNSL-HEXAMINE RESIN

#### 2.3.1 Raw materials

- a. Hexamethylenetetramine
- b. Phenol
- c. CNSL

#### 2.3.2 Procedure

### 2.4 CHARACTERIZATION

- a. Gel time
- b. Residual hexamine content
- c. Melting point
- d. Water insolubles
- e. Molecular weight
- f. Differential scanning calorimetry
- g. Thermogravimetric analysis

## **2.5 RESULTS AND DISCUSSION**

### **2.5.1 Characterization of CNSL**

### **2.5.2 Effect of phenol: formaldehyde ratio on the properties of the resin**

- a. Gel time
- b. Residual hexamine
- c. Loss in weight on extraction with water
- d. Melting point
- e. Thermogravimetric analysis
- f. Differential scanning calorimetry

### **2.5.3 Effect of CNSL: phenol ratio on the properties of the resin**

- a. Gel time
- b. Residual hexamine

## **2.6 CONCLUSIONS**

## **REFERENCES**

## **SYNTHESIS OF CNSL RESINS**

### **2.1 INTRODUCTION**

The most obvious and common method of obtaining polymeric material from CNSL is the polycondensation with formaldehyde or formaldehyde containing materials. In this work no attempt has been made to separate CNSL into its components. Such a separation leads to considerable cost escalation. The reaction of CNSL with formaldehyde is slow compared to that of phenol with formaldehyde. Further, pure CNSL-HCHO resin is a brittle substance whose mechanical properties are less impressive compared to phenol-HCHO resin (1). For these reasons this study is based on a copolymer of CNSL and phenol obtained by condensation with hexamine.

### **2.2 QUALITY CONTROL TESTS FOR CNSL (2)**

CNSL is available from cashew nut processing centers as a byproduct. In this study CNSL was procured from M/s Pierser Leslie Ltd., Kochi. The quality of CNSL was ascertained by conducting tests prescribed in IS 840 – 1964 (Table 2.1). The results of these tests conducted on CNSL are summarized in Table 2.2.

#### **a. Specific gravity**

The specific gravity of CNSL was determined using a specific gravity bottle.

#### **b. Insoluble matter**

About 50g CNSL was dissolved in four times its volume of toluene by warming on a water bath. Then the solution was filtered and the weight of residue was found.

#### **c. Volatile matter**

About 100g CNSL were heated at 205<sup>0</sup>C for 30 minutes. The loss in weight was found.

#### **d. Ash content**

About 2g of CNSL was heated by means of a burner until the ash was free from carbonaceous matter.



**e. Iodine value**

CNSL was treated in carbon tetrachloride medium with a known excess of iodine monochloride solution in glacial acetic acid. The excess iodine monochloride was treated with potassium iodide and the liberated iodine was estimated by titration with sodium thiosulphate solution.

**f. Polymerization time**

CNSL was heated at 205<sup>0</sup>C with continuous stirring till foaming ceased. Taken 5g of this dehydrated CNSL and 0.5 ml 25% solution of con. H<sub>2</sub>SO<sub>4</sub> in diethyl sulphate in a test tube. The tube kept immersed in an oil bath at 176<sup>0</sup>C. The time taken for the material to gel was taken as the polymerization time.

**g. Viscosity**

Viscosity of the sample was determined using Brookefield Viscometer (3)

**h. Molecular weight**

Both number average and weight average molecular weights were determined by Gel Permeation Chromatography (GPC) using Hewlett Packard (1081B) equipment. Tetrahydrofuran was used as the solvent. A flow rate of 1ml/min was employed and a refractive type detector was used.

**Table 2.1**  
**Indian Standards specification for CNSL**

| Characteristic  | Requirement |
|---|-------------|
| Specific gravity  | 0.95-0.97   |
| Viscosity at 30 <sup>0</sup> C, cp (max)                        | 550         |
| Moisture, % by wt. (max)  | 1.0         |
| Matter insoluble in toluene, % by wt. (max)                     | 1.0         |
| Loss in wt. on heating, % by wt. (max)                          | 1.0         |
| Ash, % by wt. (max)   | 1.0         |
| Iodine value (max)  |             |
| (a) Wijs method   | 250         |
| (b) Catalytic method  | 375         |
| Polymerization  |             |
| (a) Time, min (max)   | 4           |
| (b) Viscosity at 30 <sup>0</sup> C, cp (min)                    | 30          |
| (c) Viscosity after acid washing at 30 <sup>0</sup> C, cp (min) | 200         |

**Table 2.2**  
**Characteristics of CNSL**

| <b>Characteristics</b>   | <b>Results</b> |
|--|----------------|
| Specific gravity   | 0.954          |
| Brookfield Viscosity, cp   | 104            |
| Moisture, % by weight (max)  | 0.92           |
| Matter insoluble in toluene, % by weight (max)                             | 0.95           |
| Loss in weight on heating, % by wt.  | 0.98           |
| Ash, % by wt.  | 1.023          |
| Iodine value (Wijs)  | 249            |
| Polymerization time, min   | 10             |
| Polymerization by viscosity method<br>(Using Brookfield viscometer), cp    | 30             |
| Polymerization by viscosity after<br>acid washing at 30 <sup>o</sup> C, cp | 104            |
| Number average molecular weight  | 235            |
| Z average molecular weight   | 3070           |
| Weight average molecular weight  | 506            |
| Viscosity average molecular weight   | 406            |
| $\overline{M}_w / \overline{M}_n$  | 2.14           |
| $\overline{M}_v / \overline{M}_n$  | 1.72           |

### 2.3 PREPARATION OF CNSL- HEXAMINE RESIN

Resoles and novolaks (4) the two well-known classes of polymers belonging to the PF category can be synthesized from CNSL. Resoles are produced by reacting phenol with a molar excess of formaldehyde under basic conditions. Novolaks are produced by reacting a molar excess of phenol with formaldehyde under acidic conditions.

Initial studies conducted on CNSL with hexamine yielded a highly plastic mass. This condensation was found to require a much longer time than phenol with hexamine. The product was rubbery with very little friability. Hence it was decided to investigate the effect of copolymerizing CNSL with phenol by condensation with hexamine in various proportions. Earlier attempts to synthesize CNSL-formaldehyde (5) yielded a resin, which was employed for moulding particleboard

directly. In the case of the copolymer CNSL-phenol-hexa, the final product was a dry moulding composition.

### 2.3.1 Raw materials

#### a. Hexamethylenetetramine

Hexamine is a source of formaldehyde. Structure of hexamine is shown in Fig 2.1.

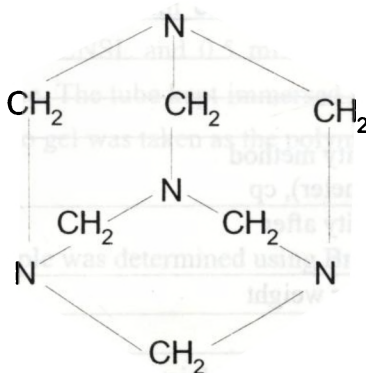

**Fig. 2.1 Structure of hexamethylenetetramine (hexamine)**

It is highly soluble in water. Aqueous solutions are reasonably stable with respect to reverse hydrolysis.



Heat promotes the above hydrolysis reaction (6). Hexamine used for the experiment was supplied by Laboratory and Industrial Chemicals, Cochin and was of industrial grade. Purity of the sample was estimated by titration against perchloric acid (6). Purity of hexamine was found out to be 94.62 %.

#### b. Phenol

Phenol of commercial grade was also supplied by Laboratory and Industrial Chemicals, Cochin. Purity was estimated by treating phenol with an excess of potassium bromate and potassium bromide; when bromination of the phenol was complete the unreacted bromine was determined by adding excess potassium iodide and back titrating the liberated iodine with standard sodium thiosulphate (7). Purity of phenol was found out to be 95 %

### c. CNSL

Refined CNSL conforming to Indian Standard IS 840 (1964) was supplied by Pierson Leslie Limited, Cochin in 200 L barrels. The average molecular weight of CNSL was determined by Gel Permeation Chromatography (GPC) using Hewlett Packard (1081 B) equipment. Tetrahydrofuran was used as the solvent. The following results were obtained.

*Number average molecular weight – 235*

*Weight average molecular weight - 506*

*Z Average molecular weight – 3070*

#### 2.3.2 Procedure

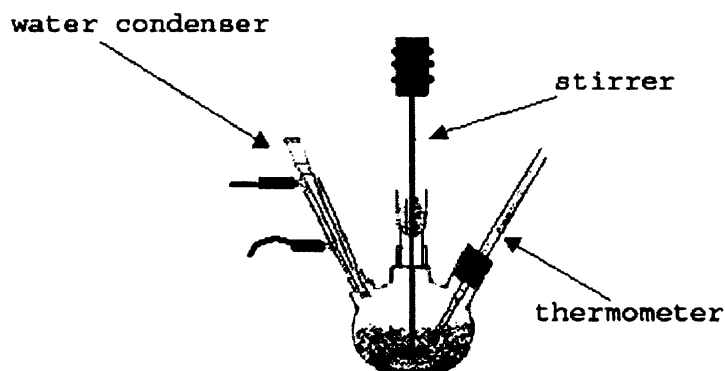

**Fig. 2.2 Experimental set up for the preparation of resin**

A three-necked 1L RB flask equipped with a stirrer passing through a mercury seal, a water condenser and a thermometer were employed for the reaction. Heating was by an electric mantle with temperature control. The total number of moles of phenolic substance was computed from knowledge of the average molecular weight of CNSL. Hexamethylenetetramine and water were taken in quantities in accordance with the hydrolysis of hexamethylenetetramine, leading to the liberation of formaldehyde

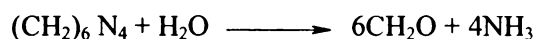

Phenol, CNSL, hexamethylenetetramine and water were weighed out and charged into the flask for a fixed CNSL: P ratio of 1:1. The P/F mole ratios were taken as 1: 2.9, 1:2.5, 1:2.3, 1:2.1, 1:1.9, 1:1.7, 1:1.5, 1:1.3, 1:1.1 and resins prepared. The CNSL: P mole ratios were taken as 100: 0, 75: 25, 50:50, 25:75 and 0:100 for the case of P: F ratio 1:2.9 and again resins prepared. Weight of phenol, CNSL and water taken for synthesis for the resins having different P: F ratios are shown in Table 2.3. Quantities taken for different CNSL: P ratios are shown in Table 2.4. The reaction was carried out at 100°C for 1.5 hours with continuous stirring. The semi-solid product was removed from the flask and it was then allowed to dry at room temperature for 3 days. The dried product was subsequently ground to a powder and again dried for 24 hours.

As a variation to this procedure the resin after synthesis was discharged from the RB flask into a glass dish and subsequently dried in an air oven for 2 hours at 100° C. Thereafter the resin was subjected to the same procedure employed in the earlier case. This additional step was aimed at completing any unfinished reaction between hexamine and phenolic materials. The resin directly tested after synthesis and room temperature drying is designated as Case A and that after oven heating as Case B.

Table 2.3

**Weight of phenol, CNSL, hexa and water employed for synthesis of the resins with different P/F ratios and a constant CNSL: P ratio of 1:1**

| COMPOSITION<br>P: F | Weight of<br>phenol (gm) | Weight of<br>CNSL (gm) | Weight of<br>hexa (gm) | Weight of<br>water (gm) |
|---------------------|--------------------------|------------------------|------------------------|-------------------------|
| 1:2.9               | 100                      | 100                    | 101                    | 12.95                   |
| 1:2.7               | 100                      | 100                    | 93.8                   | 12.06                   |
| 1:2.5               | 100                      | 100                    | 86.8                   | 11.16                   |
| 1:2.3               | 100                      | 100                    | 79.8                   | 10.26                   |
| 1:2.1               | 100                      | 100                    | 72.94                  | 9.38                    |
| 1:1.9               | 100                      | 100                    | 66.01                  | 8.49                    |
| 1:1.7               | 100                      | 100                    | 59.05                  | 7.59                    |
| 1:1.5               | 100                      | 100                    | 52.11                  | 6.69                    |
| 1:1.3               | 100                      | 100                    | 45.16                  | 5.8                     |
| 1:1.1               | 100                      | 100                    | 38.21                  | 4.91                    |

**Table 2. 4**  
**Weight of phenol, CNSL, hexa and water employed for synthesis of the resins**  
**with different CNSL/P ratios and a constant P: F ratio of 1:2.9.**

| COMPOSITION<br>CNSL/P | Weight of<br>phenol (gm) | Weight of<br>CNSL (gm) | Weight of<br>hexa (gm) | Weight of<br>water (gm) |
|-----------------------|--------------------------|------------------------|------------------------|-------------------------|
| 100/0                 | 0                        | 100                    | 28.79                  | 3.69                    |
| 75/25                 | 25                       | 75                     | 39.48                  | 5.08                    |
| 50/50                 | 50                       | 50                     | 50.33                  | 6.46                    |
| 25/75                 | 75                       | 25                     | 561.16                 | 7.85                    |
| 0/100                 | 100                      | 0                      | 71.99                  | 9.25                    |

## **2.4 CHARACTERIZATION**

The following characterization studies were conducted on the synthesized resin.

### **a. Gel time**

Gel time of 0.5g resin at 150<sup>0</sup>C was determined by a hot plate method (8). An electrically heated plate was maintained at 150<sup>0</sup>C. 0.5g resin was stoked with a spatula until the sol-gel transition occurred. Sol-gel transition was indicated by rapid increase in rubberiness or gel character of the resin. The gel time of the resin was found (a) directly after synthesis and drying and also (b) after extraction with water for 96 hours for removal of unreacted hexa.

### **b. Residual hexamine content**

0.05 g resin was dissolved in 50ml glacial acetic acid and was titrated with standardized 0.1N perchloric acid using 0.25% methyl violet as indicator until the colour changed from violet to green (6).

### **c. Melting point**

Melting point of the different samples was determined using a heated capillary tube.

**d. Water insolubles**

Water insolubles of the samples after extracting with water were determined.

**e. Molecular weight**

Molecular weight of the resin was determined in one particular case as a test case. The number average and weight average molecular weights were measured using GPC. A Hewlett Packard instrument employing a RI detector and tetrahydrofuran as solvent (flow rate 1ml/ min) was employed.

Values obtained were

For resin with P: F ratio 1: 2.9 and processing time 1.5 hours

*Number average molecular weight - 878*

*Weight average molecular weight - 3345*

*Z-average molecular weight - 67166.*

For resin with P: F ratio 1: 2.9 and processing time (1.5 + 2) hours

*Number average molecular weight- 1079*

**f. Differential scanning calorimetry**

Differential scanning calorimetry of the resin samples were done at a heating rate 10<sup>0</sup>C/minute using Mettler calorimeter .

**g. Thermogravimetric analysis**

Thermogravimetric analysis was done for the resin with P: F ratio 1:2.9 using the instrument TGA Q50 V2.34 Build 127 in the temperature range 0-800<sup>0</sup>C.

**2.5 RESULTS AND DISCUSSION**

**2.5.1 Characterization of CNSL.**

Characteristics of CNSL sample tested are shown in Table 2.1. The CNSL sample tested for quality was found to be similar in properties to standard material prescribed in the specification (Table 2.2).

## 2.5.2 Effect of phenol: formaldehyde ratio on the properties of the resin

### a. Gel time

The gel times obtained for Cases A and B are plotted in Fig. 2.3.

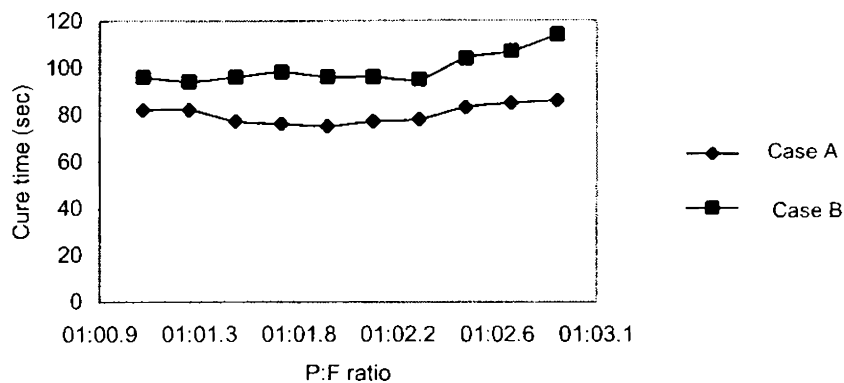
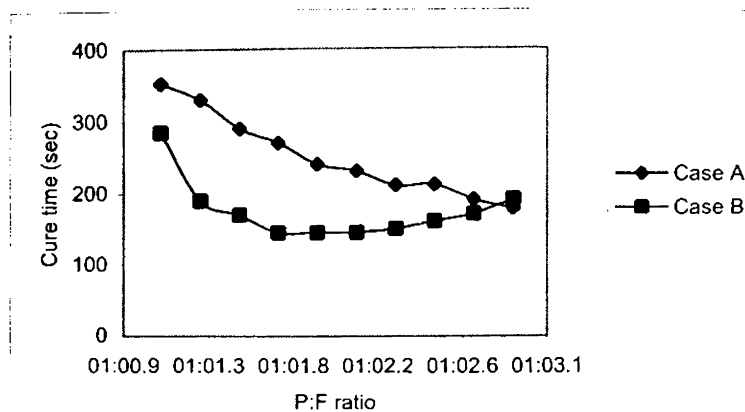

**Fig. 2.3 Variation of the gel time of the resin before extraction as a function of P: F ratio**

It is found that Case B leads to longer gel times than Case A. This may look surprising as Case B corresponds to the product obtained after a longer processing time. It is likely that a portion of unreacted hexamine decomposes during oven heating. Formaldehyde liberated does not combine with the phenol groups because of the ventilated atmosphere. This slows down the final crosslinking. This explains the longer gel times for Case B. The effect of the ratio of phenol and formaldehyde on the gel time is not very discernible. But the gel time appears to reach a minimum around a molar ratio of 1:1.9.

Fig. 2.4 shows the effect of composition on gel time after extracting the powdered resin with water.



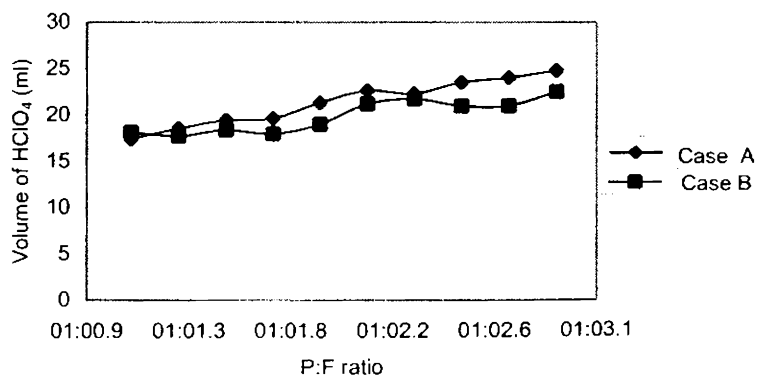

**Fig. 2.4 Variation of the gel time of the resin after extraction as a function of P: F ratio**

In both Cases A and B one can safely assume that there is no free hexamine or formaldehyde. In the absence of hexamine gel times for Case A are found to be longer than for Case B. Crosslinking under these conditions is achieved by means of methylol groups alone. Case B that has been processed for a longer time contains a larger amount of methylol groups. This accounts for shorter gel times exhibited by Case B.

**b. Residual hexamine**

Fig. 2.5 is the plot of phenol: formaldehyde ratio against volume of perchloric acid.



**Fig. 2.5 Variation of volume of perchloric acid before extraction as a function of P: F ratio**

Fig 2.5 shows the volume of  $\text{HClO}_4$  required to neutralize the resin. This value indicates the extent of unreacted hexamine. There is a difference in residual hexamine content between the two cases, though marginal.

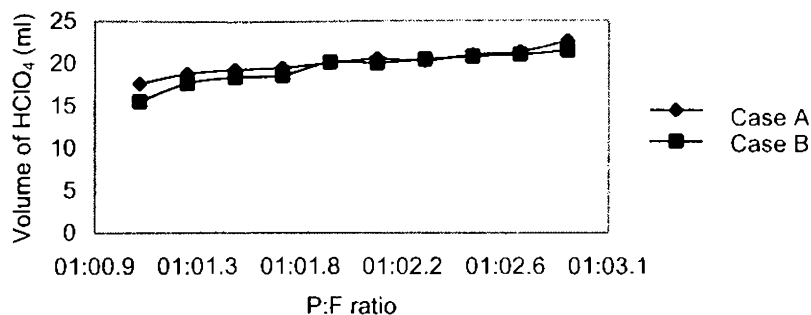
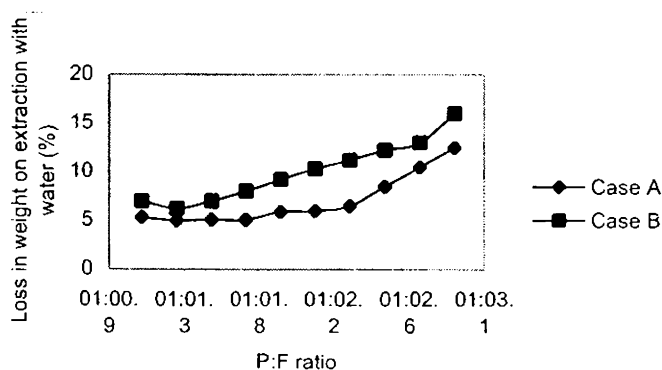

**Fig. 2.6 Variation of volume of perchloric acid after extraction as a function of P: F ratio**

Fig 2.6 shows the volume of  $\text{HClO}_4$  consumed after the samples were extracted with water as a function of phenol: formaldehyde ratio. Both cases A and B are found to give practically the same titre values. It can be concluded that both Cases A and B lead to approximately the same extent of reaction.

**c. Loss in weight on extraction with water**

Fig 2.7 shows the loss in weight on extraction with water.

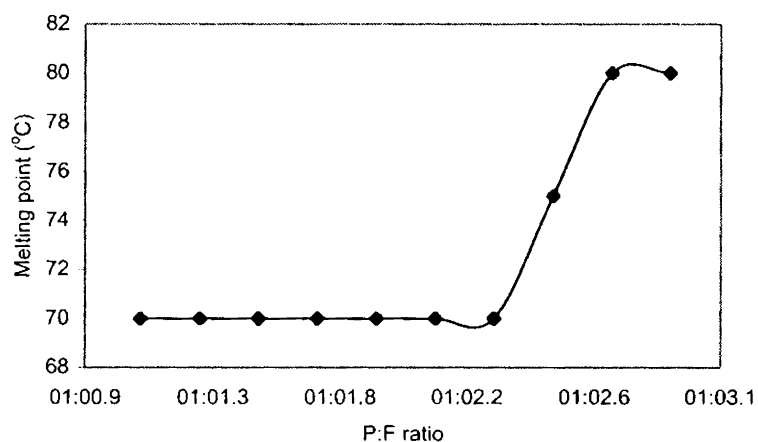

**Fig. 2.7 Variation of loss in weight on extraction with water as a function of P: F ratio**

Case B shows a higher loss in weight compared to Case A. Water soluble substances are more in the case of oven heating. Side reactions or the presence of unreacted phenol or substantial amount of water-soluble oligomers only can explain this behavior. In view of the large variety of compounds contained in CNSL one can conclude that characterization of resin by this method may not be very effective.

#### d. Melting point

Fig. 2.8 is a plot of the melting point against phenol: formaldehyde ratio.



**Fig. 2.8 Variation of melting point as a function of P: F ratio**

Melting point remains constant at 70°C until a stoichiometric ratio of 1:2.3 is reached. There is a steady increase in melting point at 1:2.5 reaching 80°C at 1: 2.7. A certain amount of condensation between resole molecules can be expected at high formaldehyde contents. This can lead to increase in molecular weight and a corresponding rise in melting point. This effect becomes noticeable at a stoichiometric ratio of 1: 2.3. The effect seems to level off at 1:2.7 and 80°C.

**e. Thermogravimetric analysis**

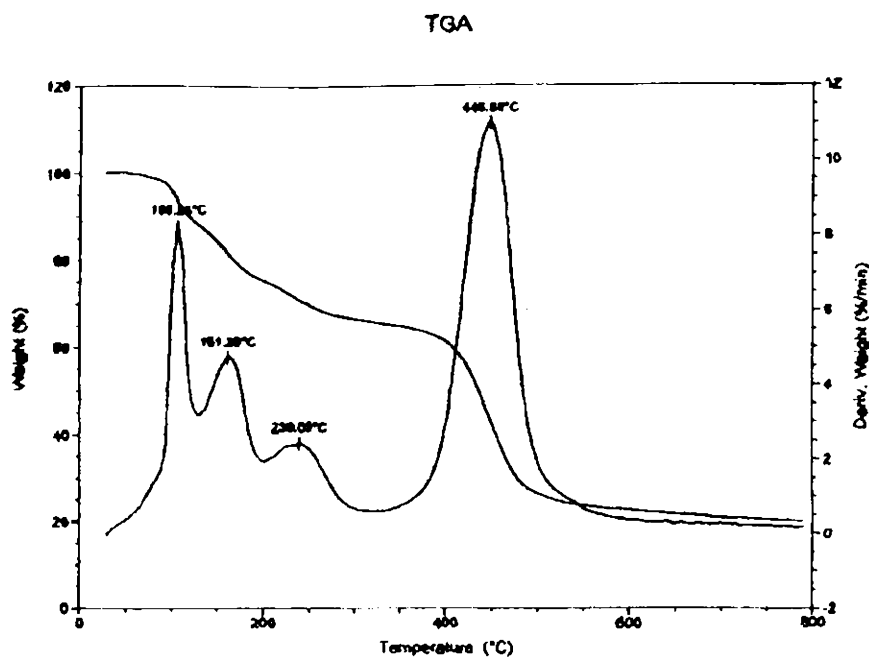

**Fig. 2.9 TGA of resin with P: F ratio 1: 2.9**

Fig.2.9 shows the TGA of resin with P: F ratio 1:2.9. The peak maxima and the corresponding temperatures are given in Table 2.11.

**Table 2.11**

**Degradation characteristics of resin with P: F ratio 1:2.9**

| Initial decomposition temperature<br>$T_i$ (°C) | Temperature of maximum rate of weight loss<br>$T_{max}$ (°C) | Maximum degradation rate (%/min) | Final decomposition temperature<br>$T_f$ (°C) | Residue at 800°C (%) |
|---|--|----------------------------------|---|----------------------|
| 100   | 446.68   | 11                               | 500   | 20                   |

**f. Differential scanning calorimetry**

The DSC of resin with different P: F ratios are given in Fig. 2.10- 2.13. As formaldehyde content increases cure temperature increases. At high formaldehyde

content high methylol groups are present in the resin. The temperature of onset of curing ( $T_i$ ), peak temperature and the temperature indicating the end of exotherm are given in Table 2.12.

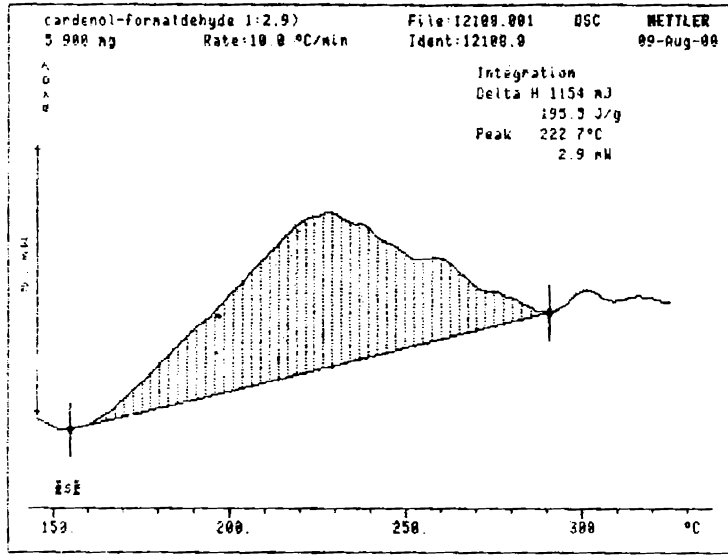

Fig. 2.10 DSC of resin with P: F ratio 1:2.9

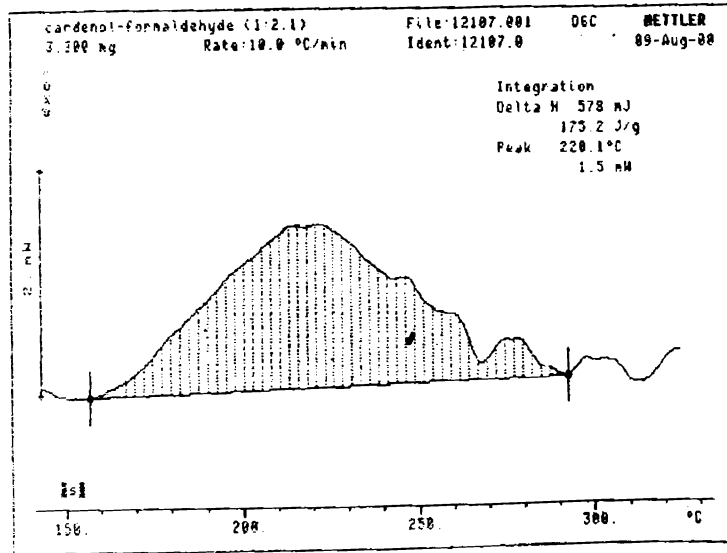

Fig. 2.11 DSC of resin with P: F ratio 1:2.3

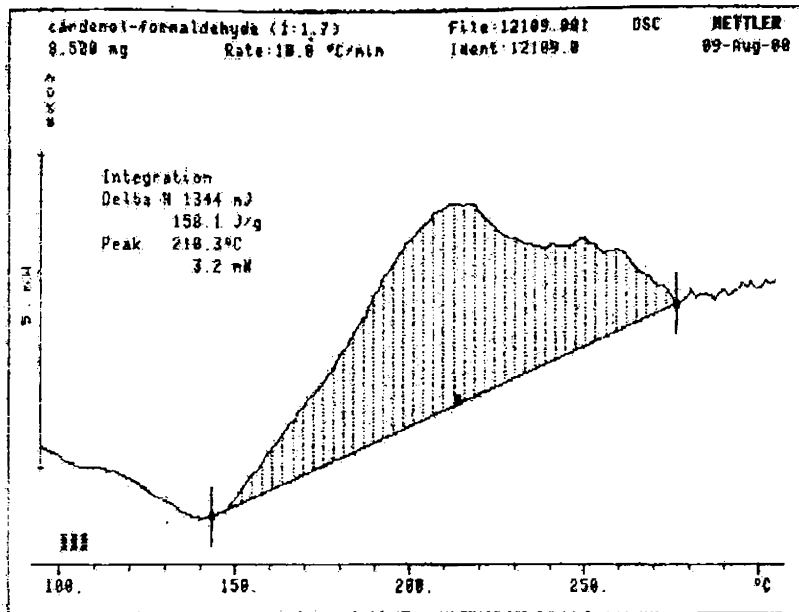

Fig. 2.12 DSC of resin with P: F ratio 1: 1.7

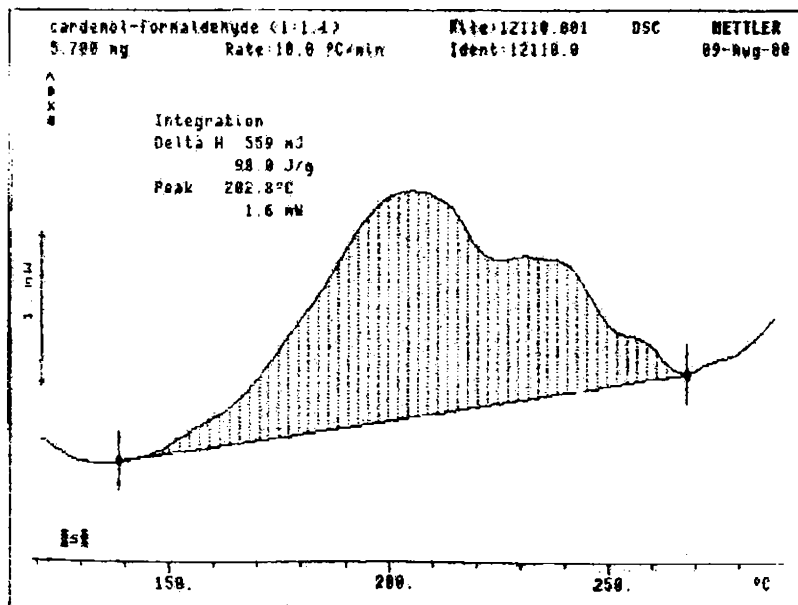

Fig. 2.13 DSC of resin with P: F ratio 1: 1.1

Table 2.12

## Differential scanning calorimetry of the resin with different P/F ratios

| COMPOSITION | Exothermal heat of cure $\Delta H$ (J/g) | Peak Temp ( $^{\circ}\text{C}$ ) | $T_{\text{onset}}$ ( $^{\circ}\text{C}$ ) | Temperature indicating end of exotherm ( $T_f$ ) |
|-------------|--|----------------------------------|---|--|
| 1:2.9       | 195.5                                    | 222.7                            | 165                                       | 285  |
| 1:2.3       | 175.2                                    | 220                              | 165                                       | 285  |
| 1:1.7       | 158                                      | 210.3                            | 150                                       | 270  |
| 1:1.1       | 98                                       | 202.8                            | 155                                       | 265  |

## 2.5.3 Effect of CNSL: phenol ratio on the properties of the resin

## a. Gel time

Table 2.13

## Gel time of resin with different CNSL/P ratios

| CNSL: P | Gel time    |
|---------|-------------|
| 100: 0  | 45 minutes  |
| 75:25   | 15 minutes  |
| 50:50   | 114 seconds |
| 25:75   | 102 seconds |
| 0:100   | 80 seconds  |

Table 2.13 shows the variation of gel time with different CNSL/P ratios. As CNSL content decreases, gel time sharply decreases. Reaction of CNSL is slow compared to phenol because of structural difference. So the gel time of resin decreases as CNSL content decreases.

## b. Residual hexamine

**Table 2.14**

**Residual hexamine content of resin with different CNSL/P ratios**

| P:CNSL | Volume of HClO <sub>4</sub> (ml) |
|--------|----------------------------------|
| 100: 0 | 1.3                              |
| 75: 25 | 3.1                              |
| 50: 50 | 22.5                             |
| 25: 75 | 22.7                             |
| 0: 100 | 22.1                             |

Table 2.14 shows the variation of resin with different CNSL/P ratios. As CNSL content increases, volume of perchloric acid increases. Reaction of CNSL is slow compared to phenol. Hence residual hexamine is likely to be more when CNSL is used. Volume of perchloric acid which is a measure of unreacted hexa increases as CNSL content increases.

## 2.6 CONCLUSIONS

CNSL used for this study conforms to IS specifications. CNSL has  $\bar{M}_n = 235$ ,  $\bar{M}_w = 506$ ,  $\bar{M}_z = 3070$ .

CNSL- phenol- formaldehyde copolymer can be synthesized by condensation between CNSL, phenol and formaldehyde. Resin prepared with a stoichiometric ratio of P: F = 1:2.9 and CNSL: P = 1:1 is found to have  $\bar{M}_n = 835$ ,  $\bar{M}_w = 3345$ ,  $\bar{M}_v = 67166$ , Decomposition temperature = 447°C. Both methods (Case A and Case B) are found to give resins of comparable properties.

Resole resin prepared from CNSL and phenol by condensation with formaldehyde has a melting point of 70 to 80°C. The melting point sharply increases from 70 to 80°C between stoichiometric ratios of 1:2.3 and 1: 2.7 between phenol and formaldehyde. The resin on crosslinking shows increasing values of heat of reaction and peak exothermic temperature with increasing formaldehyde content.

Of the two methods employed for the preparation of the resin the second method (Case B) involving an oven-heating step after condensation in an RB flask leads to longer cure times. However on extraction with water, resin prepared by the second method (Case B) is found to give a shorter cure time.



**REFERENCES**

1. P.A. Mahanwar, P.D. Kale, J. Applied Polymer Science, 61(2), 2107 (1996).
2. IS 840-1964.
3. ASTM D 2393-86.
4. L.H. Backland, J.Ind.Eng.Chem.,1 (3), 149-161 (1909).
5. P.A.Mahanwar, P.D.Kale, J. of Applied Polymer Science 61(2), 2107 (1996)
6. J. Fritz, Anal.Chem., 22, 1028 (1950).
7. J. Haslam, H.A. Willis, Identification and Analysis of Plastics, Ist edition, Iliffe Books, London (1965).
8. L Leiber, Encyclopedia of Polymer Science and Technology, Vol 11, John Wiley & Sons Inc., USA (1989)

# *Chapter 3*

## **DEVELOPMENT OF CNSL BASED ADHESIVES**

---

### **3.1 INTRODUCTION**

### **3.2 EXPERIMENTAL**

#### **3.2.1 Materials**

#### **3.2.2 Adhesive preparation**

#### **3.2.3 Adhesive formulation**

#### **3.2.4 Substrate preparation**

#### **3.2.5 Surface preparation**

#### **3.2.6 Application & curing**

#### **3.2.7 Parameters for evaluating adhesive performance**

- a. Resin content
- b. P: F ratio of resin
- c. CNSL: P ratio of resin
- d. Processing time
- e. Coupling agent
- f. Fillers
- g. Sulphur
- h. Surface treatment

#### **3.2.8 Adhesive performance**

### **3.3 RESULTS AND DISCUSSION**

#### **3.3.1 Al-Al bonding**

##### **a. Shear strength**

1. Effect of cure time and cure temperature
2. Effect of P: F ratio of resin
3. Effect of CNSL: P ratio of resin
4. Effect of processing time
  - i. Resin with P: F ratio 1: 2.9
  - ii. Resin with P: F ratio 1: 1.1

**b. Peel strength**

1. Effect of cure time
2. Effect of P: F ratio of resin
3. Effect of CNSL: P ratio

c. Effect of coupling agent on shear/ peel strength

d. Effect of carbon black on shear/ peel strength

e. Effect of silica on shear/ peel strength

f. Effect of sulphur on shear/ peel strength

**3.3.2 Rubber-metal bonding**

**a. Shear strength**

1. Effect of P: F ratio of resin
2. Effect of CNSL: P ratio of resin

**b. Peel strength**

1. Effect of P: F ratio of resin
2. Effect of CNSL: P ratio of resin

c. Effect of coupling agent on shear/ peel strength

d. Effect of carbon black on shear/ peel strength

e. Effect of silica on shear/ peel strength

f. Effect of sulphur on shear/ peel strength

**3.3.3 Rubber-rubber bonding**

**a. Shear strength**

1. Effect of P: F ratio of resin
2. Effect of CNSL: P ratio of resin

**b. Peel strength**

1. Effect of P: F ratio of resin
2. Effect of CNSL: P ratio of resin

c. Effect of coupling agent on shear/ peel strength

d. Effect of carbon black on shear/ peel strength

e. Effect of silica on shear/ peel strength

f. Effect of sulphur on shear/ peel strength

**3.4 CONCLUSIONS**

**REFERENCES**

## **DEVELOPMENT OF CNSL BASED ADHESIVES**

### **3.1 INTRODUCTION**

The adhesive formulations investigated in this study consist of CNSL based resins in combination with neoprene rubber. Rubber based adhesives have superior elongation, toughness and flexibility. They are particularly advantageous for joints in flexure. Neoprene adhesives have high bond strength, creep resistance, durability, flexibility, chemical resistance and resistance to burning. Temperature and solvent resistance of neoprene adhesives are considerably increased by additional crosslinking with thermosets especially phenolic resin, which also improves tack and adhesion. It also inhibits HCl formation during the ageing of neoprene and imparts viscosity stability (1,2). Adhesion to most materials is good due to the marked polarity of the phenolic structure. When phenolic resins are combined with elastomers, the characteristic properties of both can be utilized and specific requirements met by varying the concentration of the resins. Toughening action of such polymer blends is attributed to chemical reaction, but even more to the morphology of the cured system. Because of limited solubility of the elastomeric component a discrete, well dispersed, discontinuous phase develops in the cured phenolic matrix. The crack propagation is considerably minimized by the two-phase system and impact strength improved (3). Disadvantages of phenolic resin are its brittleness and the high curing temperature and pressure required.

CNSL is a desirable starting material for adhesive formulations due to its renewable nature, high polarity, inherent tackiness of phenolic materials and the ease with which liquid to solid conversions can be accomplished in CNSL based resin. This study aims to investigate the effect of incorporation of CNSL based phenolic heat curable resin on neoprene adhesive formulations.

### **3.2 EXPERIMENTAL**

#### **3.2.1 Materials**

- a. Isobutylene-Isoprene rubber (IIR)** was supplied by Bayer Polymers, India.

- b. **Styrene-Butadiene Rubber (SBR 1502)** was obtained from Japan Synthetic Rubbers Co.Ltd., Tokyo.
- c. **Chloroprene (CR W)** was supplied by DuPont, Akron, Ohio. Mooney viscosity ML (1+4) was 47
- d. **Zinc oxide** (activator) was supplied by M/s Meta Zinc Limited, Bombay. Heat loss, max (2hrs at 100°C) – 0.5%
- e. **Magnesium oxide (MgO)** was supplied by Fine Chemicals Ltd., Mumbai.
- f. **Precipitated silica** used was of commercial grade supplied by Sameera Chemicals, Kottayam.
- g. **Carbon black** (HAF N330) was obtained from Philip Carbon Black Limited, Kochi, India.
- h. **Toluene** was supplied by Fine Chemicals Ltd., Mumbai
- i. **Trichloroethylene** was supplied by E. Merk Limited, India.

### **3.2.2 Adhesive preparation**

Neoprene chips were milled on a two-roll mill at close nip for about 7 minutes to improve solubility. The masticated rubber was then cut to pieces and dissolved in toluene to get a CR solution in toluene. The prepared resin was dissolved in this CR adhesive solution. Details of preparation of resin are given in section 2.3. The resin concentration was varied from 25 –75 phr.

### **3.2.3 Adhesive formulation**

The basic formulation consists of the following ingredients

CR W - 100  
MgO - 4 phr  
ZnO - 5 phr  
Resin - 25-75 phr  
Toluene- 250 ml

Experiments were done to study the effect of resin content, P: F ratio of the resin and CNSL: P ratio of resin on the adhesive properties. In addition, various fillers and adhesion promoters were incorporated into the formulation to study the effect on adhesive properties.

Phenolic resin reacts with MgO. Magnesium is coordinately and chelatively bound to the hydroxyls of the methylol and phenolic groups, resulting in a three-dimensional system. This soluble MgO complex promotes solvent release and improve cohesive strength. The remaining MgO serves as an acceptor for HCl released by neoprene. ZnO is included as a curing agent and acid acceptor (2, 4).

### **3.2.4 Substrate preparation**

The substrates chosen for study were aluminium and two different elastomers. The elastomers selected were butyl rubber and SBR. Most of the rubber -to - rubber bonding (R-R) studies were done on IIR-IIR specimens. A limited number of studies were done on SBR-SBR specimens.

The compounding of rubber was done on a conventional laboratory size two-roll mill at a friction ratio 1: 1.25 and according to ASTM D 3188-00 (5) for IIR and according to ASTM D 3185-99 (6) for SBR

The formulation used for IIR is given in Table 3.1 and for SBR is given in Table 3.2.

**Table 3.1**  
**Formulation used for IIR**

|                    |      |
|--------------------|------|
| IIR                | 100  |
| ZnO                | 3    |
| Stearic Acid       | 1    |
| Sulphur            | 1.75 |
| Carbon Black (HAF) | 50   |
| TMTD               | 1    |
| MBTS               | 0.5  |
| Paraffinic oil     | 5    |
| SP                 | 4    |

**Table 3.2**  
**Formulation used for SBR**

|                    |     |
|--------------------|-----|
| SBR                | 100 |
| ZnO                | 4   |
| Stearic acid       | 2   |
| Carbon black (HAF) | 50  |
| Aromatic oil       | 10  |
| MBTS               | 0.5 |
| TMTD               | 0.5 |
| Sulphur            | 1   |
| SP                 | 4   |

Cure time of the compound was determined at 150<sup>0</sup>C on a Goettfert Elastograph (Model 67.85). Vulcanization to optimum cure time was carried out in an electrically-heated hydraulic press at 150<sup>0</sup>C. The sheet was cut into strips of 100 x 25 x 2 mm size.

Aluminium strips of size 100 mm x 25 mm were machined from <sup>1.6</sup>0.8 mm thick sheets to serve as metal substrates for shear test and <sup>0.8</sup>0.48 mm thick sheets for peel test.

### 3.2.5 Surface preparation

Surface preparation was carried out to provide an adherent surface conducive to the development of strong and durable adhesive joints. It is desirable to have the basic adherend material exposed directly to the adhesive. Surface preparation for aluminium plates was done by abrasion using 100 grit emery paper followed by solvent degreasing using trichloroethylene. For butyl and SBR substrates abrasion followed by solvent wipe using toluene was carried out prior to application of the adhesive.

A limited number of Al samples were subjected to surface treatment. Sulphuric acid- dichromate etch (ASTM D 2656-79) (7) was done by immersing the aluminium substrate in a solution containing 30 parts by weight (pbw) water, 10 pbw sulphuric acid and 1 pbw sodium dichromate for 10 minutes at 60<sup>0</sup>C and then it is washed with water and dried.

### **3.2.6 Application and curing**

After surface treatment, if any, the strips were coated with the adhesive. A single adhesive layer (approximately 0.1mm thick) was applied on each substrate on an area of 2.5 x 2.5 cms. The solvents were dried out and the substrates joined. The adhesive was then cured in a hydraulic press.

### **3.2.7 Parameters for evaluating adhesive performance**

The performance of adhesive joints was evaluated by measuring the peel and shear strength. Peel and shear strength were tested after varying each of the following parameters.

- a. **Resin content:** The concentration of resin was varied as 25, 35, 45, 55, 65 and 75 phr.
- b. **P: F ratio of resin:** 1:2.9, 1: 2.3, 1:1.7 and 1:1.1.
- c. **CNSL: P ratio of resin:** 100:0, 75:25, 50:50, 25:75 and 0:100
- d. **Processing time of resin:** 15, 30, 45, 60 and 90 minutes.
- e. **Coupling agent:** Silane adhesion promoter 3- aminopropyl triethoxy silane in varying concentrations (0, 0.25, 0.5, 0.75, 1, 1.25, 1.5 phr)
- f. **Fillers:** Carbon black and silica in varying concentrations (2, 4, 6, 8, 10 phr)
- g. **Sulphur:** Sulphur in varying concentrations (0, 0.5, 1, 1.5, 2, 2.5, 3 phr)
- h. **Surface treatment:** Sulphuric acid- dichromate etch treatment was done for aluminium samples.



### 3.2.8 Adhesive performance

Peel strength was determined as per ASTM D 903-98 (2004) (8) and shear strength as per ASTM D 1002-49 (1981) (9) with crosshead speed of 50mm/minute at room temperature using Universal Testing Machine.

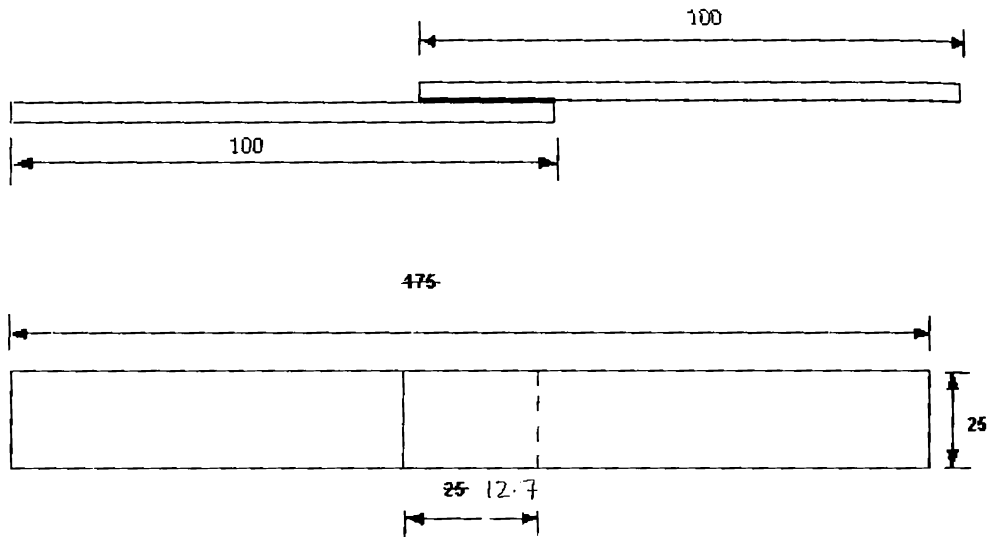

Fig. 3.1 Shear test specimen (Dimensions in mms)

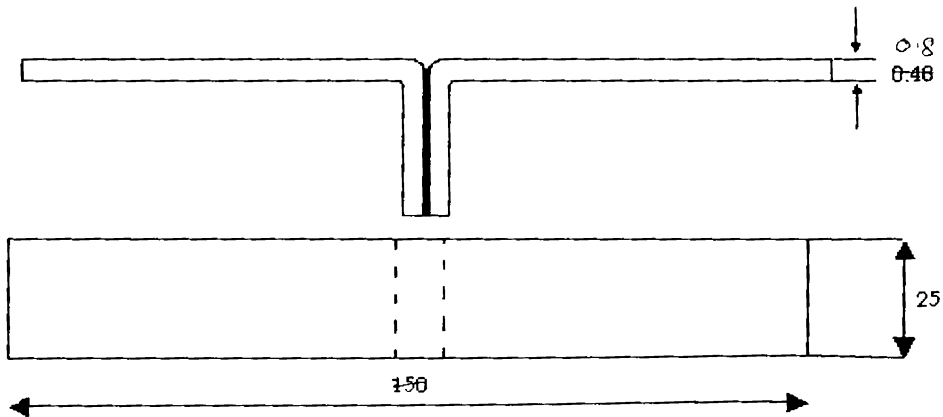

Fig. 3.2 Peel test specimen (Dimensions in mms)

### 3.3 RESULTS AND DISCUSSION

#### 3.3.1. Al-Al bonding

##### a. Shear strength

##### 1. Effect of cure time and cure temperature

Fig 3.3 shows the variation of shear strength of Al-Al bonds with cure time of the adhesives at different cure temperatures (120, 130, 140, 150 and 160°C).

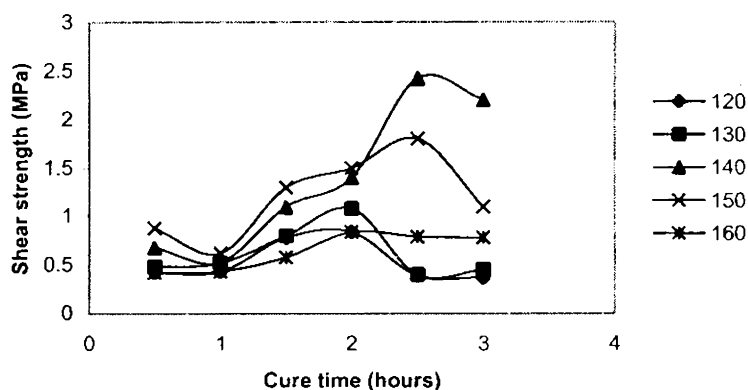

**Fig. 3.3 Variation of shear strength of Al-Al bonding with cure time for different temperatures. Resin with P: F ratio 1:2.9, CNSL: P ratio 1:1 and 45 phr resin content was used.**

The adhesive cured at 140°C and 2.5 hours shows maximum shear strength. At lower temperatures curing may not be complete and at higher temperatures shear strength decreases due to over cure. The optimum cure temperature and cure time of 140°C and 2.5 hours were selected for further studies.

## 2. Effect of P: F ratio of resin

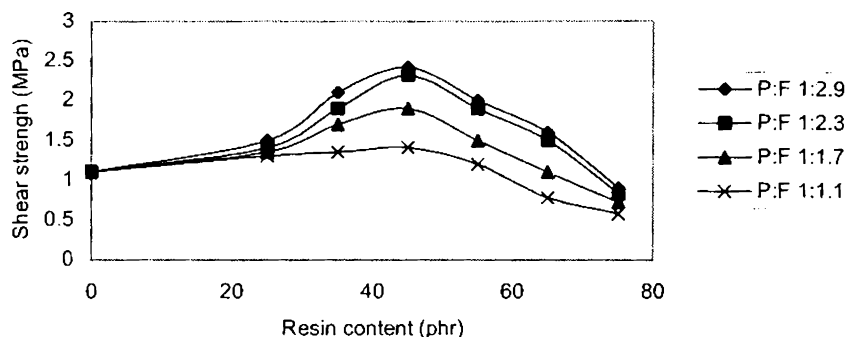

**Fig. 3.4 Variation of shear strength of Al-Al bonds with resin content for different P: F ratios. Resin with CNSL: P ratio 1:1 was used.**

Fig. 3.4 shows the variation of shear strength of Al-Al bonds with resin content for resin containing different P: F ratios (Here P refers to the total phenolic matter viz. the phenol and CNSL).

As the resin content increases shear strength increases, it reaches a maximum and then decreases. As the resin content increases, brittleness of the adhesive layer enhances. Also there is non uniform wetting of the surface. The highest shear strength is obtained for 45 phr resin content.

Higher methylol content due to higher proportions of formaldehyde can give higher polarity and better bonding. Resin with P: F ratio 1:2.9 shows high shear values compared to resins with lower P/F ratios. Phenolic resin possesses exceptional adhesive properties on metal surfaces and can form a relatively strong chemical bond by virtue of the complex formation of O- methyl hydroxyl phenol with the hydrated metal oxide surface (10) which imparts good bonding characteristics. Phenol dissociates on aluminium oxide to form aluminium phenoxide (11), which also improves bonding characteristics. In sulphur vulcanized rubbers there is sulphur-metal interaction. (12). This also improves bonding strength. Phenolic resin also leads to polar- polar interaction with the metal surface. Polar oxygen groups in the phenolic resin are capable of strong interaction with the metal surface.

### 3. Effect of CNSL: P ratio of resin

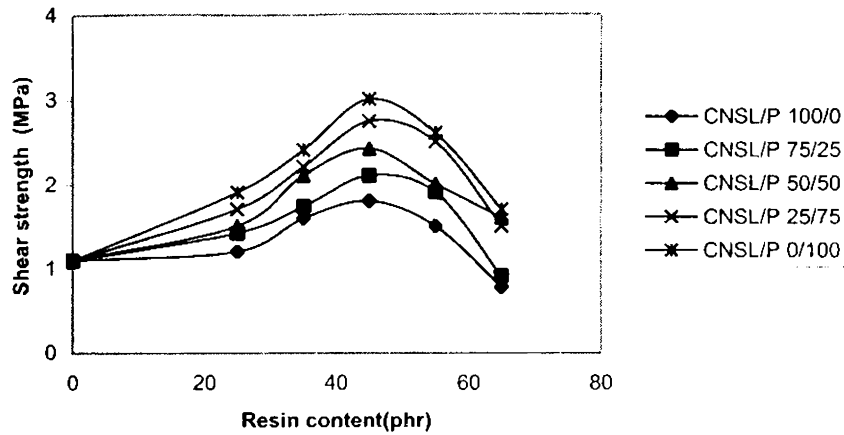

**Fig. 3.5** Variation of shear strength with resin content for different CNSL/P ratios. Resin with P: F ratio=1:2.9 was used

Fig. 3.5 shows the variation of shear strength of Al-Al bonds with resin content for resin with different CNSL: P ratios. As the CNSL content increases the value of shear strength decreases. CNSL has a long side chain which induces a plasticizing action. This may decrease the shear strength of the adhesive. However at 25% CNSL content, the values are close to those obtained by using pure phenolic resin.

4. Effect of processing time

i. Resin with P: F ratio 1:2.9

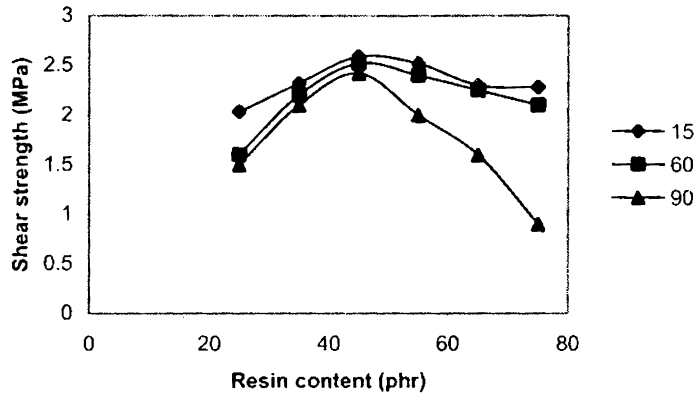

Fig. 3.6 Variation of shear strength of Al-Al bonds with processing time. Resin with P: F =1: 2.9 and CNSL: P= 1:1 was used.

Fig. 3.6 shows the variation of shear strength of Al-Al bonds with processing time of the resin with P: F =1:2.9. As the processing time increases shear strength decreases because the molecular weight of the resin reaches excessively large values. The best properties are observed for the resin processed for 15 minutes.

ii. Resin with P: F ratio 1:1.1

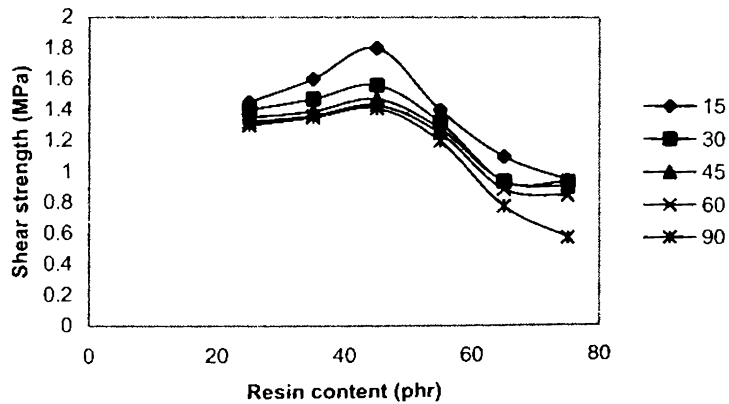
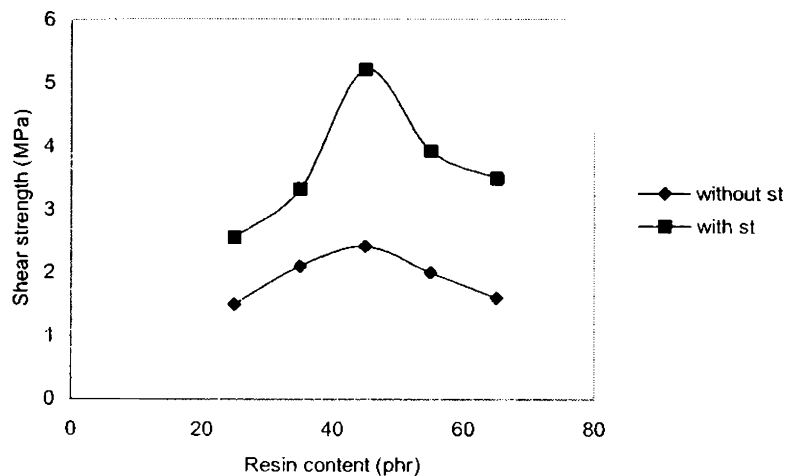

Fig. 3.7 Variation of shear strength of Al-Al bonds with processing time. Resin with P: F =1:1.1 and CNSL: P ratio =1:1

Fig. 3.7 shows the variation of shear strength of Al-Al bonds with processing time for the resin containing P: F ratio 1:1.1. In this case also as the processing time increases shear strength decreases. For this P: F ratio also (1: 1.1), the optimum processing time appears to be 15 minutes. A prolonged processing time in this case leads to fall in shear strength.

### 5. Effect of surface treatment

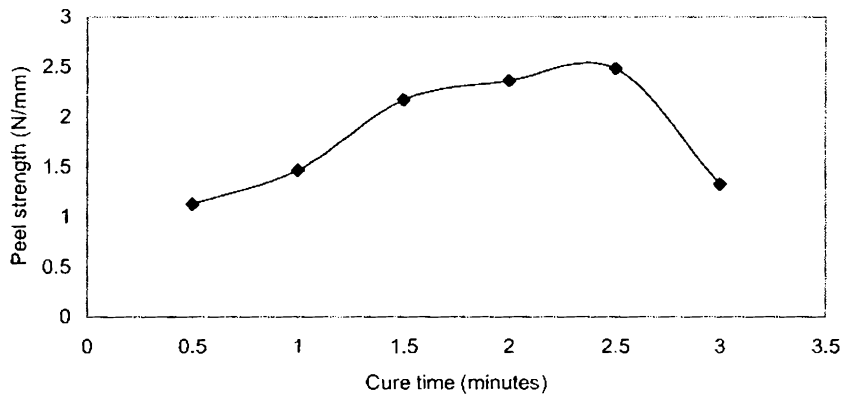

**Fig. 3.8** Variation of shear strength of Al-Al bonds with surface treatment (ST- surface treatment). Resin with P: F ratio 1:2.9 and CNSL: P ratio 1:1 was used

Fig. 3.8 shows the effect of sulphuric acid- dichromate etch (FPL etch) on shear strength of Al-Al bonds. This treatment increases the shear strength between Al and Al. Sulphuric acid- sodium dichromate etch treatment for aluminium produces a strong adherend layer of hydrated oxide  $\beta$ -  $\text{Al}_2\text{O}_3 \cdot 3\text{H}_2\text{O}$  which increases the adhesive strength (1). Both cases have a maximum value of shear strength at 45 phr of resin.

**b. Peel strength**

*1. Effect of cure time*



**Fig. 3.9 Variation of peel strength of Al-Al bonds with cure time. Resin with P: F ratio 1:2.9, CNSL: P ratio 1:1 and resin content 45 phr was used**

Fig. 3.9 shows the variation of peel strength with cure time of the adhesive at 140°C. Optimum peel strength was obtained at 2.5 hours. This agrees with the results obtained for maximum shear strength.

## 2. Effect of P: F ratio of resin

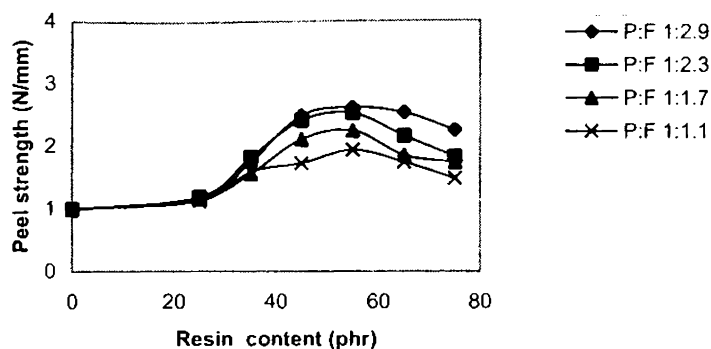
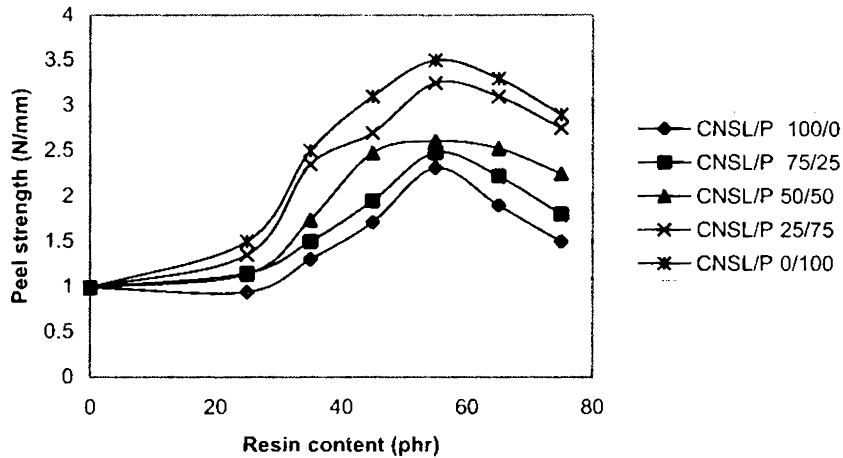

**Fig. 3.10 Variation of peel strength of Al-Al bonds with resin content for different P: F ratios. Resin with CNSL: P ratio 1:1 was used.**

Fig. 3.10 shows the variation of peel strength of Al-Al bonds with different P/F ratios. As the resin content increases peel strength increases, reaches a maximum value and then decreases. The enhancement in peel strength can be due to the increase in specific adhesion with increasing resin content. As the resin content increases beyond the optimum level, the flexibility of the system decreases, resulting in a reduction in peel strength. Resin with P: F ratio 1:2.9 shows high peel values compared to resin with higher P/F ratios. As the formaldehyde content increases, the methylol content increases and this leads to better bonding. Maximum peel strength is obtained for adhesive formulations having 55 phr resin content.



### 3. Effect of CNSL: P ratio of resin



**Fig. 3.11** Variation of peel strength of Al-Al bonds with resin content for different CNSL/P ratios. Resin with P: F ratio 1:2.9 was used.

Fig. 3.11 shows the variation of peel strength of Al-Al bonds with different CNSL/P ratios. As the CNSL content increases the value of peel strength decreases. But it is possible to replace about 25% of phenol with CNSL without too much loss of peel strength.

### c. Effect of coupling agent on shear/ peel strength

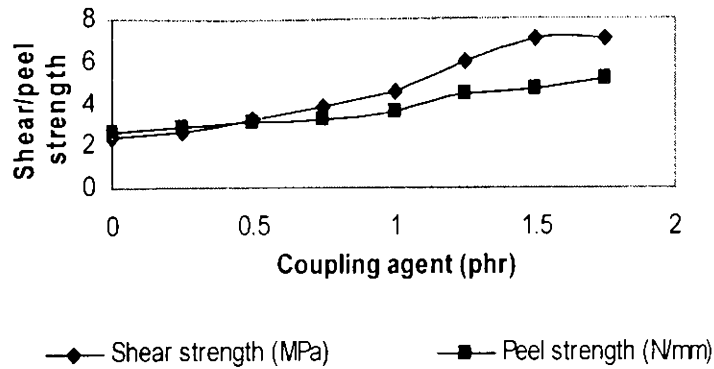

**Fig. 3.12 Effect of coupling agent on Al-Al bonding. Resin with P: F ratio 1: 2.9, CNSL: P ratio 1:1 and resin content 45 phr was used.**

Fig. 3.12 shows the variation of shear strength of Al-Al bonds and peel strength of Al-Al bonds in the presence of the coupling agent 3- amino propyl triethoxy silane. Addition of the silane improves the bonding strength of Al-Al specimens considerably. The effect of coupling agent is more noticeable in the case of shear strength. Coupling agents have the ability to migrate to the interface and improve adhesion. Silane coupling agent above 1.25 phr shows very good improvement in bonding strength values. Chemical bonds are formed between the metal oxide and siloxane. (13) Silanes can form strongly adsorbed polysiloxane films on metal surface. Polysiloxane has an open porous structure and the liquid adhesive can penetrate into them and then harden to form an interpenetrating inter phase region. Another reason for the increase in bond strength on addition of silane, may be the reaction of the amino functional group in the silane coupling agent with the adhesive resin (13). The coupling agent also improves the adhesion by improving the level of wetting. (14).

d. Effect of carbon black on shear/ peel strength

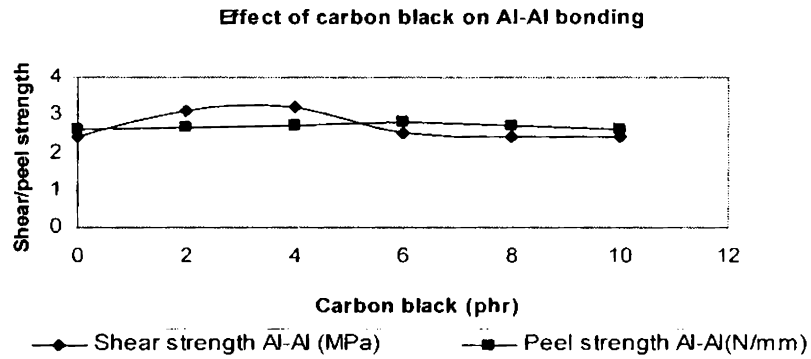

Fig. 3.13 Effect of carbon black on Al-Al bonding. Resin with P: F ratio 1: 2.9, CNSL: P ratio 1:1 and resin content 45 phr was used.

Fig. 3.13 shows the variation of shear strength and peel strength of Al-Al bonds with carbon black content. Carbon black is added to reduce the cost, increase the specific gravity and raise the viscosity of the adhesive formulation (15). The reinforcing quality of carbon black improves the shear strength marginally up to about 4 phr. After that there is a return to the original level. In general, carbon black has only moderate effect on shear and peel strengths

e. Effect of silica on shear/ peel strength

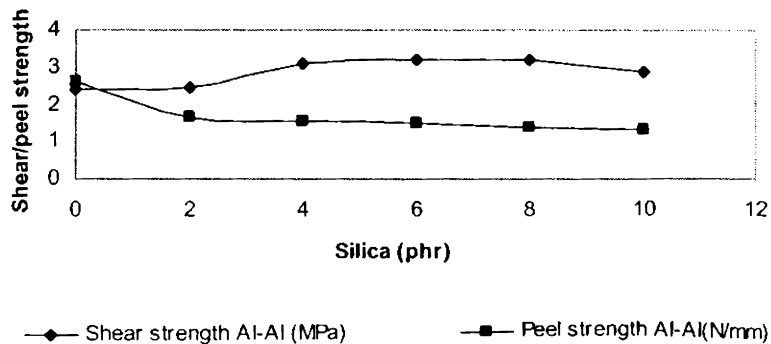
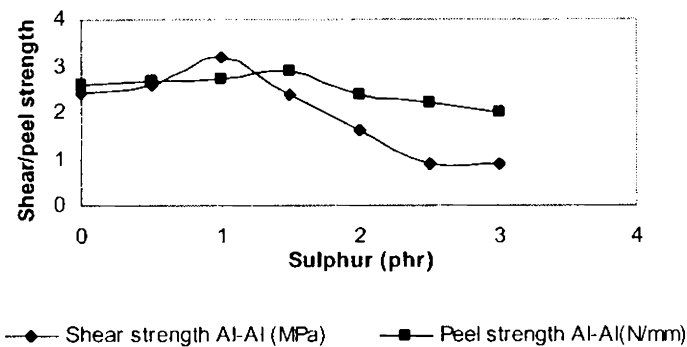

Fig. 3.14 Effect of silica on Al-Al bonding. Resin with P: F ratio 1:2.9, CNSL: P ratio 1:1 and resin content 45 phr was used.

Fig. 3.14 shows the variation of shear strength and peel strength of Al-Al bonds with silica content. Silica content above 4 phr leads to some increase in shear strength. Peel strength on the other hand is reduced by the presence of silica. There is some improvement in cohesive strength of the adhesive layer on addition of silica. It also acts as a rheological modifier, enhancing the flow properties of the adhesive and thereby properly filling of the cavities of the mechanically abraded metal surface.

**f. Effect of sulphur on shear/peel strength**



**Fig. 3.15 Effect of sulphur on Al-Al bonding. Resin with P: F ratio 1: 2.9, CNSL: P ratio 1:1 and resin content 45 phr was used.**

Fig. 3.15 shows the variation of shear strength and peel strength of Al-Al bonds with sulphur content. Low amounts of sulphur improve the shear strength of the adhesives initially. Sulphur may act as a weak adhesion promoter in this concentration range. A minimal amount of crosslinking may be responsible for this. But beyond this point there is a general deterioration of properties. The adhesion promoter quality of sulphur is not very evident in this case.

### 3.3.2. Rubber-metal bonding

Butyl rubber and aluminium substrates were used for this study.

#### a. Shear strength

##### 1. Effect of P: F ratio

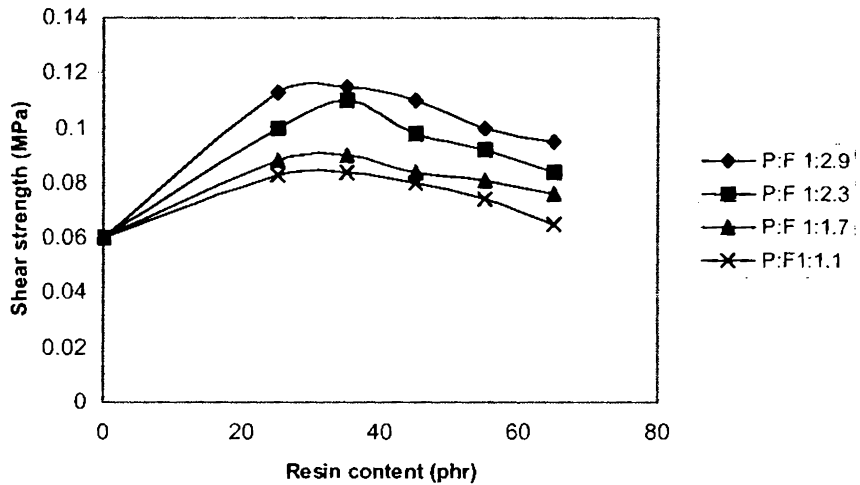

**Fig. 3.16 Variation of shear strength of IIR- Al bonds with resin content. Resin with CNSL: P ratio 1:1 was used.**

Fig. 3.16 shows the variation of shear strength IIR- Al bonds with resin content of adhesive formulation. For all P: F ratios (1:1.1, 1:1.7, 1:2.1, 1:2.9) the shear strength initially increases and reaches a maximum between 30 to 35 phr resin. On addition of higher amounts of resin there is loss in shear strength. On addition of more resin the cured adhesive becomes stiffer and its modulus increases beyond the modulus of butyl rubber. An optimum modulus is reached between a resin content of 30 to 35 phr. Higher formaldehyde content leads to higher mechanical strength and higher methylol contents. Hence a ratio of 1:2.9 between phenol and formaldehyde gives the best shear strength values.

T493

T  
678:60  
MAT

2. Effect of CNSL: P ratio of resin

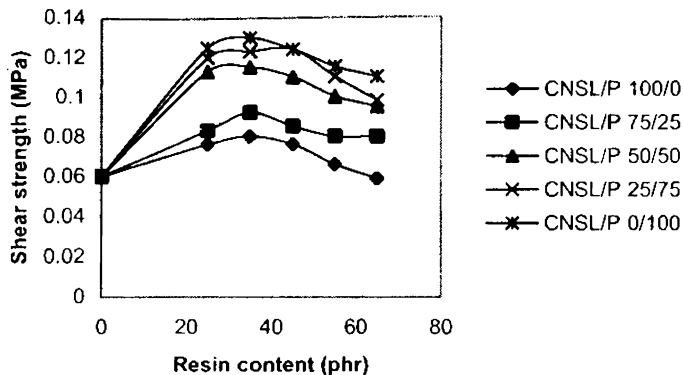

Fig. 3.17 Variation of shear strength of IIR- Al bonds for different CNSL/P ratios. Resin with P: F ratio 1: 2.9 was used.

Referring to Fig. 3.17 it is seen that the presence of CNSL leads to a steady reduction of shear strength of IIR- Al bonds. But addition of CNSL up to 25% causes only a very marginal reduction in shear strength. Steric hindrance due to aliphatic side chain of CNSL can be the reason for reduction in shear strength. Here again, maximum shear strength is observed at about 35% resin content. Replacement of 25% phenol with CNSL can be an attractive proposal.

b. Peel strength

1. Effect of P: F ratio of resin

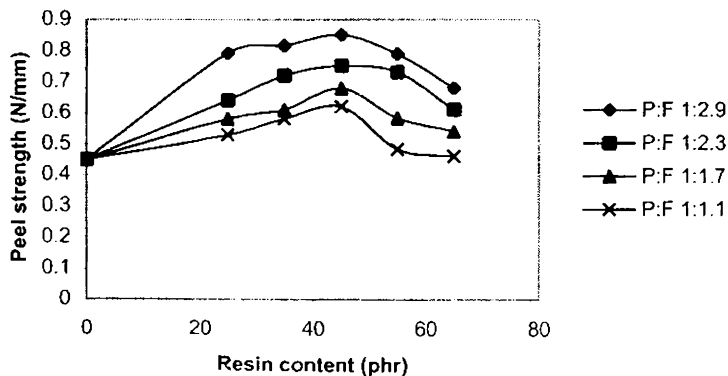
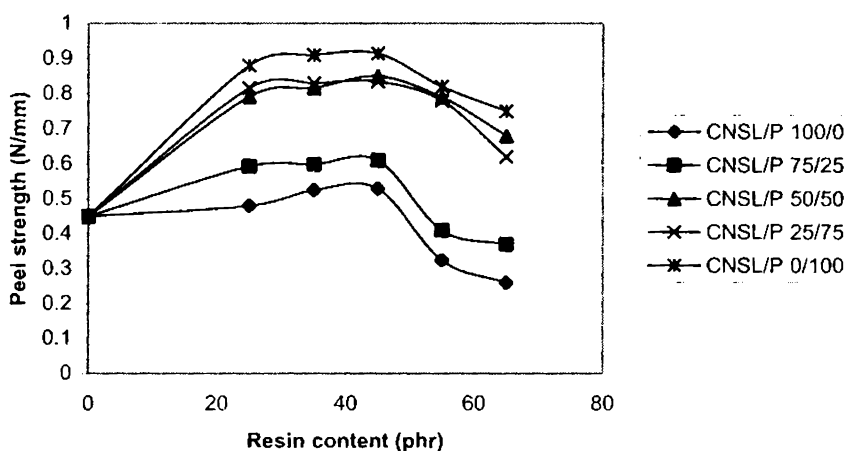

Fig. 3.18 Variation of peel strength IIR- Al bond for different P/F

Fig. 3.18 is a plot of  $180^\circ$  peel strength of IIR-Al substrates bonded with an adhesive formulation containing CNSL-phenol-hexa copolymer and neoprene rubber. Peel strength values are also not very high. Maximum values are reached about 45% resin content. Higher formaldehyde content is found to improve the peel strength. Resin content beyond 45% is found to lower the peel strength.

## 2. Effect of CNSL: P ratio of resin



**Fig. 3.19** Variation of peel strength of IIR- Al bonds for different CNSL/P ratios. Resin with P: F ratio= 1:2.9 was used.

Peel strength of IIR-Al bond as a function of resin content is shown in Fig. 3.19. About 45% resin content is seen to be optimum, although in the range 25-45% the variation is not much. In agreement with earlier observations pure phenol gives the best results, although replacing it with up to 25% CNSL does not lower the peel strength much.

## c. Effect of coupling agent on shear/ peel strength

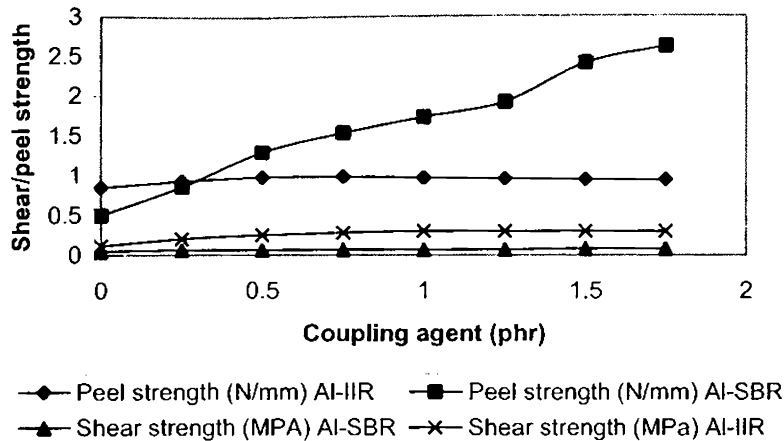

**Fig. 3.20 Effect of coupling agent on R- M bonding. Resin with P: F ratio 1: 2.9, CNSL: P ratio 1:1 and resin content 45 phr was used.**

Fig. 3.20 shows the effect of addition of a coupling agent to adhesive formulation. The coupling agent used is 3- aminopropyl triethoxysilane. Only in the case of peel strength of Al- SBR bonds the coupling agent concentration shows any influence on the adhesive properties. Al-SBR bonds show a high value of peel strength on addition of 1 to 1.75 phr of coupling agent. There is hardly any effect on the shear properties of Al- SBR bonds. The addition of coupling agent depends on the nature of the substrate and this particular coupling agent is found to work well for improvement of peel strength of Al-SBR bonds but not shear strength. The coupling agent has no effect on the performance of Al-IIR bonds.



d. Effect of carbon black on shear/ peel strength

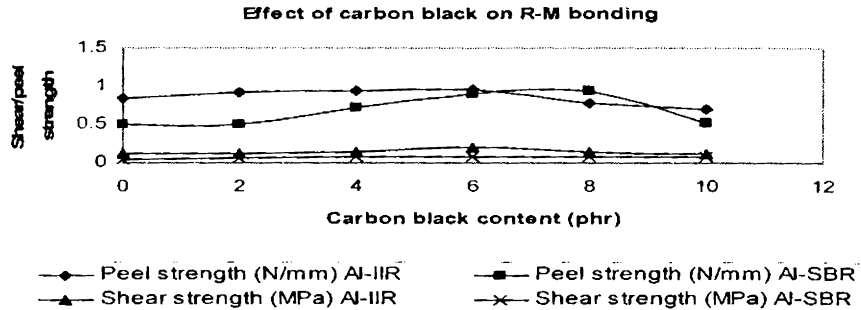

Fig. 3.21 Effect of carbon black on R- M bonding. Resin with P: F ratio 1: 2.9, CNSL: P ratio 1:1 and resin content 45 phr was used.

Addition of carbon black is seen to improve somewhat the peel strength of AI- IIR and AI- SBR substrates. This effect is more marked in the case of SBR. An optimum carbon black content of 6 to 8% is indicated. The improvement in cohesive strength resulting from the presence of carbon black is responsible for better peel strength. Carbon black tie up more rubber per unit weight of carbon thereby enhancing cohesive forces (16). Beyond 8% peel strength decreases due to decrease in molecular flexibility.

e. Effect of silica on shear/ peel strength

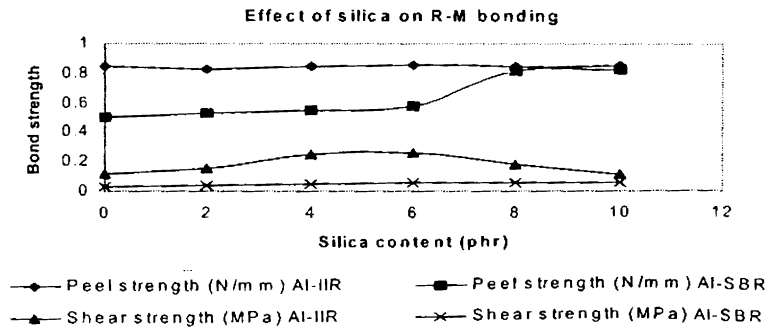
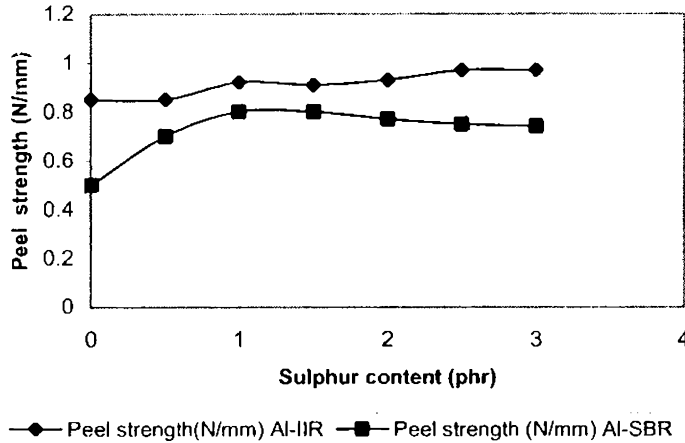

Fig. 3.22 Effect of silica on R- M bonding. Resin with P: F ratio 1: 2.9, CNSL: P ratio 1:1 and resin content 45 phr was used.

Addition of silica to the formulation for Al-SBR bonding shows improvement in peel strength beyond 6% (Fig. 3.22). The effect on peel and shear strength of Al- IIR bonds and shear strength of Al-SBR bonds is negligible.

**f. Effect of sulphur on shear/ peel strength**



**Fig. 3.23 Effect of sulphur on R- M bonding. Resin with P: F ratio 1: 2.9, CNSL: P ratio 1:1 and resin content 45 phr was used.**

Varying amounts of sulphur were added to the formulation for bonding IIR and SBR to Al. Sulphur is known to enhance adhesion between metallic (17) and rubber substrates. Fig. 3.23 shows the variation in peel strength of rubber metal specimens on adding progressively larger amounts of sulphur. There is not much variation in bonding strength on addition of sulphur although slight improvement is noticed in the case of Al-SBR.

**3.3.3 Rubber-rubber bonding**

Butyl- butyl specimens were employed for most of the experiments. The rest of the experiments were on SBR-SBR specimens.

**a. Shear strength**

**1. Effect of P: F ratio of resin**

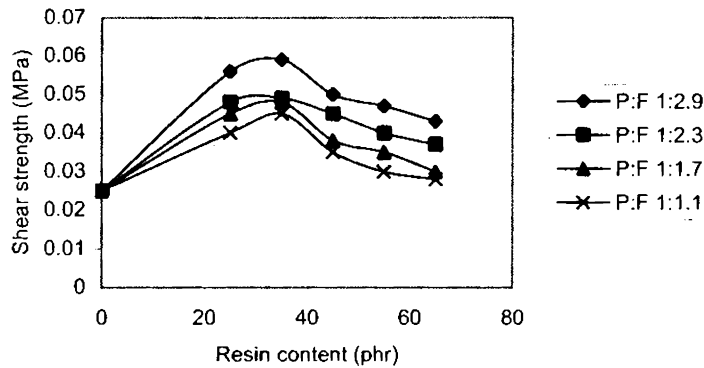

**Fig. 3.24** Variation of shear strength of IIR- IIR bonds for different P/F ratios. CNSL: P ratio= 1:1

Fig. 3.24 is a plot of change in shear strength with resin content for butyl/butyl substrates. Here again a P: F ratio 1: 2.9 gives the best results. Optimum resin content appears to occur at about 30 to 35 phr. The shear strength values attained for IIR-IIR bonding are not high. Comparing the results obtained for Al-Al bonding (Section 3.10.1) the performance of these adhesive formulation for IIR-Al bonding and IIR-IIR bonding is not satisfactory.

**2. Effect of CNSL: P ratio of resin**

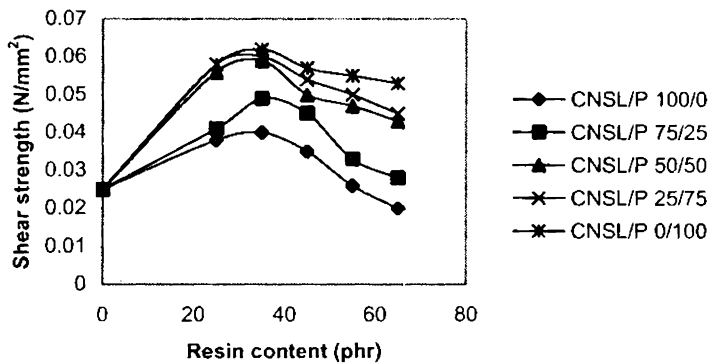

**Fig. 3.25** Variation of shear strength IIR- IIR bonds for different CNSL/P ratios. P: F ratio 1: 2.9.

Fig. 3.25 shows the variation of shear strength of butyl – butyl bonds with resin content. Each curve corresponds to one ratio of CNSL/P. As in the earlier case

pure phenol gives the best properties. But replacement of phenol up to 25 phr with CNSL is seen to affect the performance very little. An optimum shear strength occurs at around 35 phr resin content.

**b. Peel strength**

**1. Effect of P: F ratio of resin**

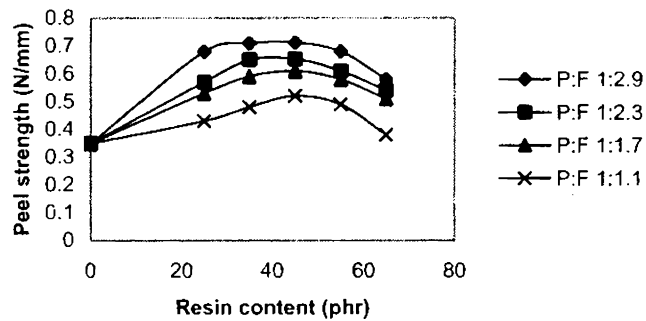

**Fig. 3.26 Variation of peel strength IIR- IIR bond for different P/F ratios. Resin with CNSL: P ratio 1:1 was used.**

Fig. 3.26 shows the variation in peel strength of IIR-IIR bonds with resin content of the formulation. Each graph corresponds to a different P: F ratio. The higher the formaldehyde content the better the peel strength. In the range of 35 to 55% for most cases the peel strength is not very sensitive to resin content.

2. Effect of CNSL: P ratio of resin

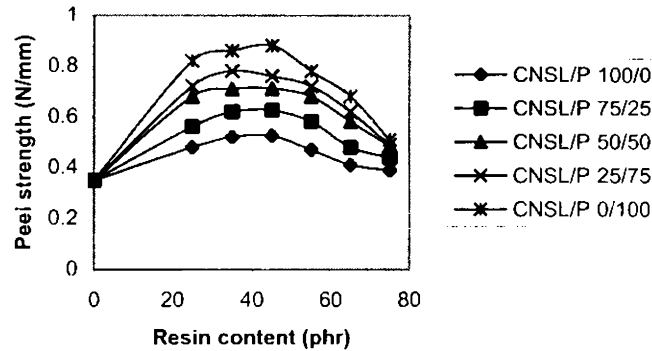

Fig. 3.27 Variation of peel strength IIR- IIR bond for different CNSL/P ratios. Resin with P: F ratio 1:2.9 was used.

The variation of peel strength of butyl- butyl bonds with resin content is shown in Fig. 3.27 where each curve represents a different CNSL/P ratio. Although pure phenol gives the best results partial replacement with CNSL upto 25% appears to be a viable alternative. Peel strength is found to reduce with increase of resin content beyond 45%. Higher resin content leads to higher modulus and presumably too high a modulus for IIR-IIR bonding.

b. Effect of coupling agent on shear/ peel strength

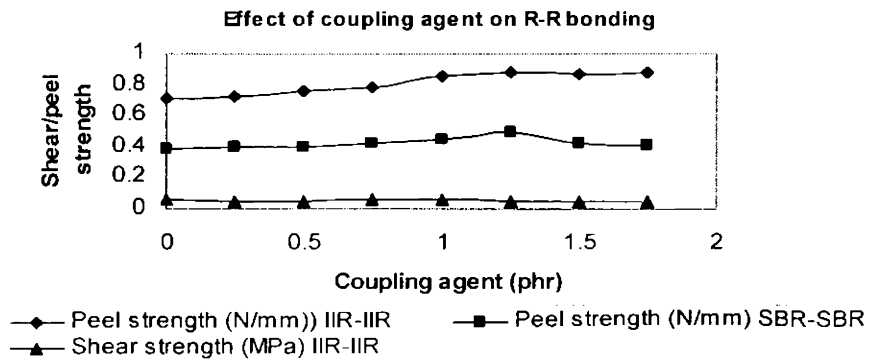
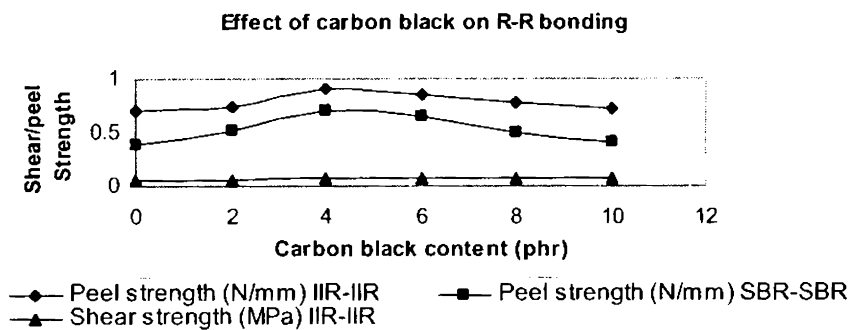

Fig. 3.28 Effect of coupling agent on R- R bonding. Resin with P: F ratio 1:2.9, CNSL: P ratio 1:1 and resin content 45 phr was used.

Fig. 3.28 shows the effect of varying amounts of coupling agent on shear and peel strength of butyl-butyl substrates. There is only a small improvement in shear and peel strength. The effect on SBR-SBR bonds is also negligible. The coupling agent works well only with metallic substrates.

#### d. Effect of carbon black on shear/ peel strength

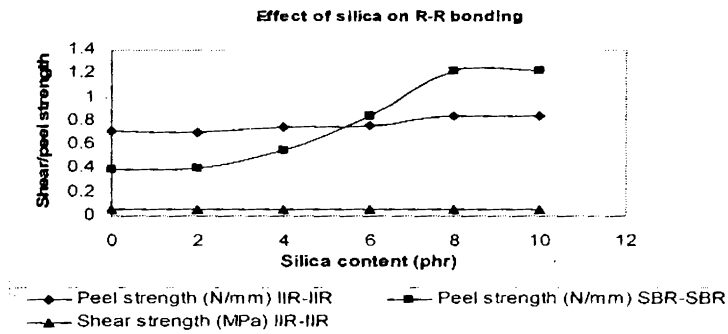

**Fig. 3.29 Effect of carbon black on R- R bonding. Resin with P: F ratio 1: 2.9, CNSL: P ratio 1:1 and resin content 45 phr was used.**

Fig. 3.29 shows the effect of carbon black on butyl-butyl bonding. At about 4 phr carbon black content, peel strength of both IIR-IIR and SBR-SBR specimens shows the maximum improvement, though moderate. Shear strength of IIR-IIR specimens, on the other hand, does not show any improvement on addition of carbon black. This is in agreement with observations made in Section 3.10.2 on the effect of carbon black on the peel strength of IIR-Al bonds.

Carbon black generates a unique three-dimensional visco- elastic network which produces a partial immobilization of the chain segments of the polymer and improves the strength of the elastomer. Increasing the carbon black loading serves to make additional carbon black surface available for rubber attachments and improves the peel strength up to 4phr. Further addition of carbon black decreases the peel strength. The reduction in strength may be due to agglomeration of the carbon black aggregates to a domain that acts like a foreign body or due to the physical contact between adjacent aggregates (18).

e. Effect of silica on shear/ peel strength



**Fig. 3.30 Effect of silica on R- R bonding. Resin with P: F ratio 1: 2.9, CNSL: P ratio 1:1 and resin content 45 phr was used.**

Fig. 3.30 shows the effect of silica content on IIR-IIR and SBR-SBR specimens. SBR-SBR specimens show improvement in peel strength from 4 phr onwards. Substantial improvement is noticed at 8 phr which remains constant on addition of more silica. Shear strength of IIR-IIR specimens does not improve on addition of silica.

f. Effect of sulphur on shear/ peel strength

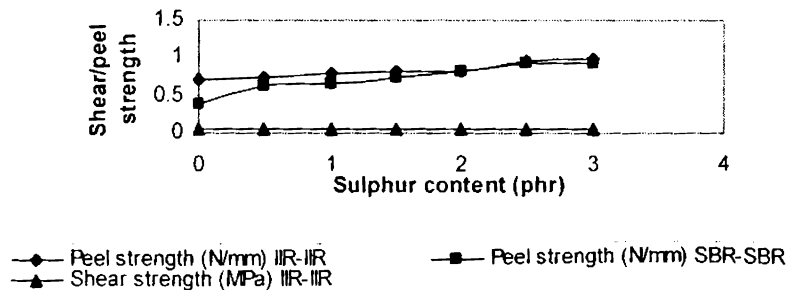

**Fig. 3.31 Effect of sulphur on rubber- rubber bonding. Resin with P: F ratio 1: 2.9, CNSL: P ratio 1:1 and resin content 45 phr was used.**

Fig. 3.31 shows the variation in shear/ peel strength of rubber specimens on adding progressively larger amounts of sulphur. A marginal improvement in adhesive formulation is observed in the case of peel strength of IIR-IIR and SBR-SBR bonds. Chemical interaction between sulphur and the rubber substrates can be the underlying reason. Shear properties of IIR-IIR bonds, however, do not show any improvement.

Table 3.3 shows the optimum values of coupling agent, carbon black, silica and sulphur for M-M bonding, R-M bonding and R-R bonding.

**TABLE 3.3**

**Optimum values of coupling agent, carbon black, silica and sulphur for M-M bonding, R-M bonding and R-R bonding.** (Resin with P: F ratio 1:2.9, CNSL:P ratio 1:1 and resin content 45 phr was used)

| Optimum value  | Al-Al bonding        |                      | Al-SBR bonding       | R-R bonding          |         |
|----------------|----------------------|----------------------|----------------------|----------------------|---------|
|                | Shear strength (MPa) | Peel strength (N/mm) | Peel strength (N/mm) | Peel strength (N/mm) |         |
|                |                      |                      |                      | SBR-SBR              | IIR-IIR |
| Coupling agent | 1.5 phr              | 1.5 phr              | 1.75phr              | 1.25 phr             | 1 phr   |
| Carbon black   | 4 phr                | 4 phr                | 8 phr                | 4 phr                | 4 phr   |
| silica         | 4phr                 | Decreases            | 8 phr                | 8 phr                | 8 phr   |
| sulphur        | 1 phr                | 1.5 phr              | 1 phr                | 2.5 phr              | 2.5 phr |



### 3.4 CONCLUSIONS

Judging from the bonding studies on Al-Al specimens a cure time of 2.5 hours and a cure temperature 140°C are found to give the best results for an adhesive formulation consisting of neoprene and CNSL-phenol-hexa copolymer. A resin content of 45- 55 phr at a P: F ratio of 1: 2.9 gives the best overall properties. Addition of 3- aminopropyl triethoxy silane improves the shear strength and peel strength of adhesives used in metal-to-metal bonding considerably. Although phenol alone gives the best shear and peel strengths, replacement of phenol with 25% CNSL for resin synthesis gives an almost equivalent performance.

Peel and shear strength values obtained for IIR-Al bonding are not very high. However, the best peel strength is obtained when 45 phr resin of P: F ratio 1:2.9 and CNSL: P ratio 1:1 is added to the formulation. The same resin when added at the rate of 35 phr gives maximum shear strength. Addition of coupling agent is seen to give higher peel strength in the case of SBR-Al bonds only. Addition of HAF carbon black up to 8 phr improves the peel strength of SBR-Al bonds. Addition of 6-8 phr silica improves the peel strength of Al-SBR bonds

For IIR-IIR bonds, similarly, 35-45 phr resin of P: F ratio 1: 2.9 gives the highest shear and peel strengths. In this case also, 25% phenol can be replaced with CNSL with very little loss in properties. Addition of coupling agent has no substantial effect on the shear / peel strength of SBR-SBR and IIR-IIR bonds. Carbon black improves the peel strength in these cases marginally upto a maximum of 4 phr. Silica enhances the peel strength of SBR-SBR bonds marginally. Sulphur also improves the peel strength of SBR-SBR bonds to a moderate extent.

The peel and shear values reached indicate that this adhesive system is better suited for Al-Al bonding than either of IIR-Al or IIR-IIR bonding.

### REFERENCES

1. J. Shields, Adhesive Hand book, 2<sup>nd</sup> edition, Newnet Butterworth, London (1976)
2. I. Skiest, 2<sup>nd</sup> edition, Van Nostrand Reinhold, New York (1977).
3. A.K.W. Scheib, Chemistry and Application of Phenolic Resins, Springer-Verlag, Berlin Heidelberg (1977).

4. Encyclopedia of Polymer Science and Technology, Vol 1, Wiley Interscience publications, John Wiley & Sons, Inc., New York, 556 (1985)
5. ASTM D 3188-00
6. ASTM D 3185-99
7. ASTM D 2656-79
8. ASTM D 903-98 (2004)
9. ASTM D 1002-49 (1981)
10. H.Kollek, Int.J. Adhesion and Adhesives, 5, 75 (1985)
11. W.H. Weinberg, J.Vac. Sci. Technol., 11, 262 (1979)
12. B.G. Crowther, Rapra Review Reports, 8(3), 6 (1996)
13. A.J Kinloch, Adhesion and Adhesives, PP 156-157, Chapman and Hall, New York (1981).
14. J.A. Brydson, Plastic Materials, Butterworth-Heinemann Ltd., 7<sup>th</sup> edition, London, 128 (1999).
15. G.F Morton and G.B Quinton in Rubber Technology and Manufacture, C.M Blow and Hepburn (eds), P 467, Butterworths, London (1977)
16. M.Kardan, Carbon black reinforcement of adhesives and sealants, paper presented at the Adhesive and Sealant Council, Spring Convention, Las Vegas, April (2000)
17. C.P.J. van der Aar, L.van der Does, J.W.M. Noordemeer and A. Bantger, Progress in Rubber and Plastic Tech., Vol 16, No 2, 87-115 (2000)
18. B.B. Boonstran in: Rubber Technology, Van Nostrand Reinhold, New York (1973)

# *Chapter 4*

## **AGEING STUDIES ON RUBBERS MODIFIED BY CNSL-PHENOL- HEXA RESIN**

---

### 4.1 INTRODUCTION

### 4.2 COMPOUNDING AND CURING OF ELASTOMERS

#### 4.2.1 Materials

- a. Elastomers
- b. Compounding ingredients
- c. Solvents

### 4.3 COMPOUNDING OF RUBBERS BY TWO ROLL MILLING

- a. NBR
- b. SBR
- c. IIR
- d. CR
- e. EPDM
- f. NR

### 4.4 DETERMINATION OF CURE CHARACTERISTICS

### 4.5 MOULDING AND SAMPLE PREPARATION

### 4.6 AGEING STUDIES

### 4.7 TESTING

- a. Tensile strength, elongation at break and modulus
- b. Tear strength
- c. Miscellaneous tests
  1. Compression tests.
  2. Durometer hardness
  3. Abrasion resistance
  4. Swelling index
  5. Density
  6. Acetone soluble matter
  7. Toluene soluble matter

4.8 REACTION OF PHENOLIC RESIN WITH ELASTOMERS

4.9 RESULTS AND DISCUSSION

4.9.1 NBR- Effect of resin on the ageing properties of vulcanizates.

- a. Resin content
- b. P: F ratio of resin
- c. CNSL: P ratio of resin

4.9.2 SBR – Effect of resin on the ageing properties of vulcanizates

- a. CNSL content.
- b. Resin content
- c. P: F ratio of resin

4.9.3 Effect of resin content on the ageing properties of miscellaneous rubbers

- a. IIR
- b. CR
- c. EPDM
- d. NR

4.10 CONCLUSIONS

REFERENCES

## **AGEING STUDIES ON RUBBERS MODIFIED BY CNSL-PHENOL- HEXA RESIN**

### **4.1. INTRODUCTION**

The linear molecules of a rubber need to be crosslinked into a network to get the desired physical properties in the final product. The crosslinking agents generally used are sulfur and various accelerators, metal oxides, multifunctional compounds, peroxides etc, depending on the nature of the rubber. During crosslinking the rubber passes from a predominantly plastic state to a predominantly elastic one because of the formation of intermolecular bridges.

The mechanical properties of crosslinked rubber undergo a marked change on heating with deterioration in elasticity and strength. The behaviour of rubber when exposed to high temperatures is strongly influenced by the presence or absence of oxygen. More than half of the total change observed on ageing can be attributed to oxidation processes (1). Reaction with oxygen causes chain scission and /or crosslinking. After oxidation a vulcanizate softens or stiffens depending on whether chain scission or crosslinking is more extensive (2-10).

Crosslink shortening with additional crosslink formation, crosslink destruction along with main chain modification and cyclic sulfide formation, S-S bond interchanges and degradation of the rubber backbone occur during ageing (11). These are due to post curing phenomena in which free sulfur is used up in forming new crosslinks and the destruction of the weakest polysulfidic linkages.

The phenomenon of reversion or deterioration of properties, in sulfur based cure systems is due to the decomposition of polysulfidic crosslinks (12-15). This leads to a reduction in crosslink density and consequently a loss of mechanical properties. The chemical changes associated with reversion result in crosslink shortening and crosslink destruction.

Since reversion due to ageing is an undesirable feature of vulcanizates, various compounding methods have been developed to minimize it. There are three possible approaches to this problem. I The established and best-known method to minimize reversion is the efficient cure system. These vulcanization systems reduce reversion by diminishing polysulfidic crosslinks and generating mono and

disulfidic crosslinks in the networks (16). This approach is effective when lowering the sulfur levels does not negatively influence other desirable properties like fatigue, flexural properties, hysteresis etc. II Another solution to counteract reversion is to compensate for the loss of crosslink density and reduce main chain modifications by adding a reactive chemical to the rubber compound to produce thermally stable C-C crosslinks. This allows rubber compounds to operate under more severe service conditions (17). III The loss in physical properties of sulfur cured vulcanizates can also be controlled by adding age resistors that are capable of reacting with the agents causing deterioration of elastomers. Thus the service life of sulfur cured vulcanizates at elevated temperature can be increased by using phenol- formaldehyde resins. These resins can give very thermally stable crosslinks and the vulcanizates are immune to reversion at higher use temperatures (18-20).

In this study, the effect of varying the resin content, CNSL: P ratio (CNSL/P – 100/0, 75/25, 50/50, 25/75, 0/100) and total phenol: formaldehyde ratio (P: F – 1: 2.9, 1:2.3, 1:1.7, 1:1.1) of the resin was studied by incorporating the resin into rubber vulcanizates and testing the properties of the vulcanizates before and after ageing for 1 to 10 days at 100<sup>0</sup>C in an air oven.

## **4.2. COMPOUNDING AND CURING OF ELASTOMERS**

A number of elastomers were subjected to study. These included Acrylonitrile- Butadiene Rubber (NBR), Styrene-Butadiene Rubber (SBR 1502), Isobutylene-Isoprene Rubber (IIR), Chloroprene (CR), Ethylene Propylene Rubber (EPDM) and Natural Rubber (NR).

### **4.2.1 Materials**

#### ***a. Elastomers***

1. **Acrylonitrile- Butadiene Rubber (NBR)** was obtained from Apar Polymers Limited, India. The sample used was grade N 553 with 33% acrylonitrile content and having Mooney viscosity ML (1+4) at 100<sup>0</sup>C of 45.
2. **Styrene-Acrylonitrile Rubber (SBR 1502)** was obtained from Japan Synthetic Rubbers Co.Ltd., Tokyo.

Specifications of SBR

|                         |         |
|-------------------------|---------|
| Volatile matter, % mass | - 0.23  |
| Ash, % mass             | - 0.24  |
| Organic acid            | - 5.53% |
| Bound styrene           | - 24.3  |

3. **Isobutylene-Isoprene Rubber (IIR)** was supplied by Bayer Polymers, India.

4. **Chloroprene (CR W)** was supplied by DuPont, Akron, Ohio.

Mooney viscosity ML (1+4) at 100<sup>0</sup>C - 47

5. **Ethylene Propylene Rubber (EPDM)** was supplied by Zenith Rubber and Plastic Works, Mumbai.

6. **Natural Rubber (NR)** – ISNR- 5 was supplied by the Rubber Research Institute of India, Kottayam, Kerala. Specifications of ISNR-5 is given below.

Mooney viscosity ML (1+4) at 100<sup>0</sup>C – 82

Dirt content, % by mass, max – 0.05

Volatile matter, % by mass, max – 1

Nitrogen, % by mass, max – 0.7

Ash, % by mass, max – 0.6

Initial plasticity, min – 30

Plasticity retention index – 60

*b. Compounding ingredients*

1. **Zinc Oxide** (acivator) was supplied by M/s Meta Zinc Limited, Bombay. It had the following specifications.

Specific gravity – 5.5

ZnO content – 98%

Acidity – 0.4%

Heat loss, max (2hrs at 100<sup>0</sup>C) – 0.5%

2. **Stearic acid** (co-activator) used in the study was supplied by Godrej Soaps (Pvt) Ltd, Bombay and had the following specifications.

Specific gravity – 0.85 ± 0.01

|               |                        |
|---------------|------------------------|
| Melting point | – 50-69 <sup>0</sup> C |
| Acid number   | – 185-210              |
| Iodine number | – 9.5                  |
| Ash content   | – 0.1%                 |

3. **Sulphur** was supplied by Standard Chemical Company (Pvt) Ltd, Chennai. The sample used had the following specifications

|                               |             |
|-------------------------------|-------------|
| Specific gravity              | – 2.05      |
| Acidity                       | – 0.01% max |
| Ash                           | – 0.015 max |
| Solubility in CS <sub>2</sub> | – 98%       |

4. **Tetramethylthiuram disulphide (TMTD)** – It was supplied by Flexys, Netherlands. It had the following specifications

|                  |                      |
|------------------|----------------------|
| Melting point    | - 108 <sup>0</sup> C |
| Moisture content | - 0.12%              |
| Ash              | - 0.03%              |

5. **Mercaptobenzothiazol disulphide (MBTS)**

MBTS was supplied by Bayer Chemicals, Bombay. It had a melting point of 165<sup>0</sup>C and specific gravity- 1.34

6. **Ethylene thiourea (NA 22)**

NA 22 was commercial grade supplied by Standard Chemical Company (Pvt) Ltd., Chennai. It had the following specifications

|                               |             |
|-------------------------------|-------------|
| Specific gravity              | – 2.05      |
| Acidity                       | – 0.01% max |
| Ash                           | – 0.01% max |
| Solubility in CS <sub>2</sub> | – 98%       |

7. **Magnesium Oxide (MgO)** was supplied by Fine Chemicals Ltd., Mumbai.

Specifications

|                      |      |
|----------------------|------|
| Water soluble matter | - 25 |
|----------------------|------|



|  |   |         |
|--|---|---------|
| Loss in ignition at 100 <sup>0</sup> C | - | 8%      |
| Chloride                               | - | 0.1%    |
| Sulphate                               | - | 0.5%    |
| Arsenic                                | - | 0.0001% |
| Iron                                   | - | 0.1%    |
| Lead                                   | - | 0.002%  |

8. **Octylated diphenylamine** was supplied by Yasho Industries Ltd., Mumbai, India.

9. **Styrenated Phenol (SP)** was supplied by Olympic Chemicals, Maharashtra, India.

10. **Precipitated silica** used was of commercial grade supplied by Sameera Chemicals, Kottayam. The specifications are given below

|                                      |   |      |
|--------------------------------------|---|------|
| PH (5% aqueous solution)             | - | 6.3  |
| Specific gravity                     | - | 2.03 |
| SiO <sub>2</sub> on dried sample     | - | 90%  |
| Loss on heating (105 <sup>0</sup> C) | - | 5.5% |

11. **Carbon black (HAF N330)** was obtained from Philip Carbon Black Limited, Kochi, India. It had the following specification

|                |   |                       |
|----------------|---|-----------------------|
| Appearance     | - | black granules        |
| DBP absorption | - | 102 cc/100g           |
| Pour density   | - | 376 kg/m <sup>3</sup> |
| Iodine number  | - | 82                    |

12. **Diethylene glycol (DEG)** was supplied by E. Merk Limited, India.

13. **Diocetyl phthalate (DOP)** was supplied by Vensbar Chemicals (P) Ltd, India and had the following specifications

|                  |   |      |
|------------------|---|------|
| Specific gravity | - | 0.98 |
| Viscosity (cp)   | - | 60   |

14. **Aromatic oil** was supplied by Hindustan Petroleum Corporation. It had the following specifications

|                                   |   |                   |
|-----------------------------------|---|-------------------|
| Specific gravity                  | - | 0.95 -0.98        |
| Viscosity gravity constant (VGC)- |   | 0.907             |
| Aniline point                     | - | 38 <sup>0</sup> C |

15. **Naphthenic oil** was supplied by Indian Oil Corporation. It had the following specifications

|                            |   |                   |
|----------------------------|---|-------------------|
| Colour                     | - | light             |
| Pour point                 | - | 20                |
| Aniline point              | - | 78 <sup>0</sup> C |
| Viscosity gravity constant | - | 0.85-0.9          |
| Aromaticity                | - | 10                |

16. **Paraffinic oil** was supplied by M/s Hindustan Petroleum Limited, India. It had the following specifications

|                            |   |                   |
|----------------------------|---|-------------------|
| Viscosity gravity constant | - | 0.85              |
| Aniline point              | - | 96 <sup>0</sup> C |

*c. Solvents*

1. **Toluene** was supplied by Fine Chemicals Ltd., Mumbai.

Specifications

|                     |   |                 |
|---------------------|---|-----------------|
| Boiling range       | - | 95 <sup>0</sup> |
| Acidity             | - | 0.012           |
| Alkalinity          | - | 0.012           |
| Non volatile matter | - | 0.002%          |

2. **Acetone (AR)** grade was supplied by Qualigens Fine Chemicals. It had the following specifications

|                            |   |             |
|----------------------------|---|-------------|
| Minimum assay              | - | 99.5%       |
| Wt/ml at 20 <sup>0</sup> C | - | 0.789-0.791 |
| Refractive index           | - | 1.35- 1.36  |

### 4.3 COMPOUNDING OF RUBBERS BY TWO ROLL MILLING

Mixing and homogenization of elastomers and compounding ingredients were done on a laboratory size two roll mill. The two roll mill used has rolls of 150 mm diameter and 320 mm length. The mill is equipped with retaining guides, with a distance between the guides at the nip of 250 to 280 mm. The ratio between slow roll and fast roll is 1: 1.25. The clearance between the rolls is adjustable from 0.2 to 8 mm as a minimum range of adjustment.

The mixing was done according to ASTM standards. Rubber was masticated on a cold mill and the compounding ingredients were then incorporated. Resin was added along with the filler. Resin content was varied from 0 to 25 phr. Resins with different phenol: CNSL ratios (CNSL/P – 100/0, 75/25, 50/50, 25/75 and 0/100) and total phenol: formaldehyde ratios (P: F – 1: 2.9, 1:2.3, 1:1.7 and 1:1.1) were incorporated into the rubber.

#### a. NBR

NBR is a copolymer of acrylonitrile and butadiene. Structural formula of NBR is

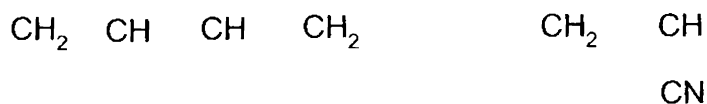

n

NBR is less permeable to gases and have good oil resistance. Due to polarity NBR vulcanizates have higher electrical conductivity.

It was initially compounded using Formulation I which employs a combination of three fillers. As this formulation was difficult to mix subsequently Formulation II which employs only silica filler was employed. Figs 4.1- 4.13 are based on Formulation I and Figs 4.14- 4.23 are based on Formulation II.

NBR was compounded as per ASTM D 3187-00 (2004) (21).

**Table 4.1**  
**Formulation I used for NBR mixing**

|                   | R0  | R5  | R10 | R15 | R20 | R25 |
|-------------------|-----|-----|-----|-----|-----|-----|
| NBR               | 100 | 100 | 100 | 100 | 100 | 100 |
| ZnO               | 4   | 4   | 4   | 4   | 4   | 4   |
| Stearic acid      | 2   | 2   | 2   | 2   | 2   | 2   |
| S                 | 1.5 | 1.5 | 1.5 | 1.5 | 1.5 | 1.5 |
| TMTD              | 0.2 | 0.2 | 0.2 | 0.2 | 0.2 | 0.2 |
| MBTS              | 1   | 1   | 1   | 1   | 1   | 1   |
| Silica            | 50  | 50  | 50  | 50  | 50  | 50  |
| Clay              | 50  | 50  | 50  | 50  | 50  | 50  |
| CaCO <sub>3</sub> | 50  | 50  | 50  | 50  | 50  | 50  |
| DOP               | 5   | 5   | 5   | 5   | 5   | 5   |
| DEG               | 2   | 2   | 2   | 2   | 2   | 2   |
| SP                | 2   | 2   | 2   | 2   | 2   | 2   |
| CI resin          | 5   | 5   | 5   | 5   | 5   | 5   |
| Resin             | 0   | 5   | 10  | 15  | 20  | 25  |

**Table 4.2**  
**Formulation II used for NBR mixing**

|              | R0  | R5  | R10 | R15 | R20 | R25 |
|--------------|-----|-----|-----|-----|-----|-----|
| NBR          | 100 | 100 | 100 | 100 | 100 | 100 |
| ZnO          | 4   | 4   | 4   | 4   | 4   | 4   |
| Stearic acid | 2   | 2   | 2   | 2   | 2   | 2   |
| S            | 1.5 | 1.5 | 1.5 | 1.5 | 1.5 | 1.5 |
| TMTD         | 0.2 | 0.2 | 0.2 | 0.2 | 0.2 | 0.2 |
| MBTS         | 1   | 1   | 1   | 1   | 1   | 1   |
| Silica       | 50  | 50  | 50  | 50  | 50  | 50  |
| DOP          | 5   | 5   | 5   | 5   | 5   | 5   |
| DEG          | 2   | 2   | 2   | 2   | 2   | 2   |
| Resin        | 0   | 5   | 10  | 15  | 20  | 25  |

**b. SBR**

SBR consists of about 25% styrene, with butadiene making up the remainder.



Heat resistance of SBR is better but low temperature flexibility and tensile strength are less than for natural rubber. Its vulcanizates are poor conductors of electricity.

SBR was compounded as per ASTM D 3185 -99 (22). In the case of SBR an additional study was conducted to investigate the effect of directly adding CNSL to the formulation instead of the resin. This formulation is given in Table 4.3. The effect of addition of the resin was studied using the formulation given in Table 4.4

**Table 4.3**  
**Formulation used for SBR for mixing CNSL directly**

|                     | C0  | C5  | C10 | C15 | C20 | C25 |
|---------------------|-----|-----|-----|-----|-----|-----|
| <b>SBR</b>          | 100 | 100 | 100 | 100 | 100 | 100 |
| <b>ZnO</b>          | 4   | 4   | 4   | 4   | 4   | 4   |
| <b>Stearic acid</b> | 2   | 2   | 2   | 2   | 2   | 2   |
| <b>S</b>            | 2   | 2   | 2   | 2   | 2   | 2   |
| <b>TMTD</b>         | 0.2 | 0.2 | 0.2 | 0.2 | 0.2 | 0.2 |
| <b>MBTS</b>         | 0.8 | 0.8 | 0.8 | 0.8 | 0.8 | 0.8 |
| <b>Carbon black</b> | 50  | 50  | 50  | 50  | 50  | 50  |
| <b>Aromatic oil</b> | 5   | 5   | 5   | 5   | 5   | 5   |
| <b>CNSL</b>         | 0   | 5   | 10  | 15  | 20  | 25  |

**Table 4.4**  
**Formulation used for SBR for mixing resin**

|                     | R0         | R5         | R10        | R15        | R20        | R25        |
|---------------------|------------|------------|------------|------------|------------|------------|
| <b>SBR</b>          | <b>100</b> | <b>100</b> | <b>100</b> | <b>100</b> | <b>100</b> | <b>100</b> |
| <b>ZnO</b>          | <b>4</b>   | <b>4</b>   | <b>4</b>   | <b>4</b>   | <b>4</b>   | <b>4</b>   |
| <b>Stearic acid</b> | <b>2</b>   | <b>2</b>   | <b>2</b>   | <b>2</b>   | <b>2</b>   | <b>2</b>   |
| <b>S</b>            | <b>2</b>   | <b>2</b>   | <b>2</b>   | <b>2</b>   | <b>2</b>   | <b>2</b>   |
| <b>TMTD</b>         | <b>0.2</b> | <b>0.2</b> | <b>0.2</b> | <b>0.2</b> | <b>0.2</b> | <b>0.2</b> |
| <b>MBTS</b>         | <b>0.8</b> | <b>0.8</b> | <b>0.8</b> | <b>0.8</b> | <b>0.8</b> | <b>0.8</b> |
| <b>Carbon black</b> | <b>50</b>  | <b>50</b>  | <b>50</b>  | <b>50</b>  | <b>50</b>  | <b>50</b>  |
| <b>Aromatic oil</b> | <b>5</b>   | <b>5</b>   | <b>5</b>   | <b>5</b>   | <b>5</b>   | <b>5</b>   |
| <b>Resin</b>        | <b>0</b>   | <b>5</b>   | <b>10</b>  | <b>15</b>  | <b>20</b>  | <b>25</b>  |

**c. IIR**

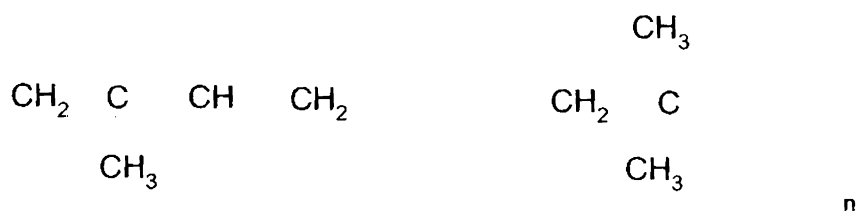

IIR consists of isobutene with a minor part of isoprene.

IIR has excellent impermeability to gases, outstanding dielectric properties, good resistance to tearing, good ageing properties at elevated temperatures and good chemical stability. They also resist weathering, sunlight, ozone, mineral acids, oxygenated solvents, water absorption, animal and vegetable oils. Resistance to flexing and abrasion is outstanding. IIR was compounded as per ASTM D 3188-00 (23)

**Table 4.5**  
**Formulation used for IIR**

|                       | R0  | R5  | R10 | R15 | R20 | R25 |
|-----------------------|-----|-----|-----|-----|-----|-----|
| <b>IIR</b>            | 100 | 100 | 100 | 100 | 100 | 100 |
| <b>ZnO</b>            | 4   | 4   | 4   | 4   | 4   | 4   |
| <b>Stearic acid</b>   | 2   | 2   | 2   | 2   | 2   | 2   |
| <b>S</b>              | 2   | 2   | 2   | 2   | 2   | 2   |
| <b>TMTD</b>           | 1   | 1   | 1   | 1   | 1   | 1   |
| <b>MBTS</b>           | 0.5 | 0.5 | 0.5 | 0.5 | 0.5 | 0.5 |
| <b>Carbon black</b>   | 50  | 50  | 50  | 50  | 50  | 50  |
| <b>Paraffinic oil</b> | 5   | 5   | 5   | 5   | 5   | 5   |
| <b>Resin</b>          | 0   | 5   | 10  | 15  | 20  | 25  |

**d. CR**

Structure of CR is

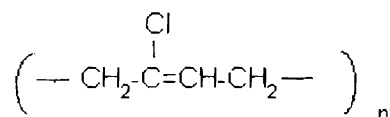

CR has good mechanical strength, high ozone and weather resistance, good ageing resistance, low flammability, good resistance towards chemicals, moderate oil and fuel resistance and adhesion to many substrates. CR was compounded as per ASTM D 3190-00 (24)

**Table 4.6**  
**Formulation used for CR**

|                                | R0  | R5  | R10 | R15 | R20 | R25 |
|--------------------------------|-----|-----|-----|-----|-----|-----|
| <b>CR</b>                      | 100 | 100 | 100 | 100 | 100 | 100 |
| <b>MgO</b>                     | 4   | 4   | 4   | 4   | 4   | 4   |
| <b>ZnO</b>                     | 5   | 5   | 5   | 5   | 5   | 5   |
| <b>Carbon black</b>            | 50  | 50  | 50  | 50  | 50  | 50  |
| <b>Naphthenic oil</b>          | 5   | 5   | 5   | 5   | 5   | 5   |
| <b>Ethlene thiourea</b>        | 0.5 | 0.5 | 0.5 | 0.5 | 0.5 | 0.5 |
| <b>Octylated diphenylamine</b> | 1   | 1   | 1   | 1   | 1   | 1   |
| <b>Resin</b>                   | 0   | 5   | 10  | 15  | 20  | 25  |

**e. EPDM**

In EPDM, ethylene and propylene monomers combined to form a chemically saturated stable polymer backbone and a third conjugated diene monomer is terpolymerized in a controlled manner to maintain a saturated backbone and place the reactive unsaturation in a side chain available for vulcanization. The two most widely used diene monomers are ethylene norbornene and dicyclopentadiene.

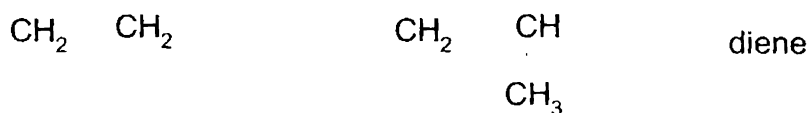

**EPDM polymer structure is**

EPDM have excellent ageing resistance, ozone resistance, weather resistance and resistance to chemicals. Colour retention in coloured compounds is excellent. It exhibits good dielectric qualities and high heat resistance. Low temperature properties are excellent. Resilience and tensile strength of EDDM rubbers are low, and resistance to petroleum derivatives extremely poor. EPDM was compounded as per ASTM D 3568-03 (25)

**Table 4.7  
Formulation used for EPDM**

|                | R0  | R5  | R10 | R15 | R20 | R25 |
|----------------|-----|-----|-----|-----|-----|-----|
| EPDM           | 100 | 100 | 100 | 100 | 100 | 100 |
| ZnO            | 4   | 4   | 4   | 4   | 4   | 4   |
| Stearic acid   | 2   | 2   | 2   | 2   | 2   | 2   |
| S              | 1   | 1   | 1   | 1   | 1   | 1   |
| TMTD           | 0.5 | 0.5 | 0.5 | 0.5 | 0.5 | 0.5 |
| MBTS           | 2   | 2   | 2   | 2   | 2   | 2   |
| Carbon black   | 50  | 50  | 50  | 50  | 50  | 50  |
| Paraffinic oil | 5   | 5   | 5   | 5   | 5   | 5   |
| Resin          | 0   | 5   | 10  | 15  | 20  | 25  |



**f. NR**

The rubber hydrocarbon component of NR consists over 99.99% of linear cis 1,4 polyisoprene.

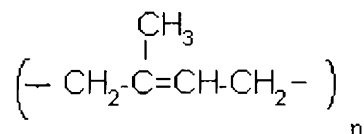

Average molecular weight of polyisoprene in NR ranges from 200,000 to 400,000 with a relatively broad molecular weight distribution. Due to this broad molecular weight distribution, NR has excellent processing behavior. NR has high tensile strength, high rebound elasticity, good low temperature flexibility, excellent dynamic properties, low heat build up and very good resistance to abrasion and fatigue. Poor resistance to oil and ozone and fuels are the drawbacks.

NR was compounded as per ASTM D 3184 –89 (26)

**Table 4.8**  
**Formulation used for NR**

|                           | R0         | R5         | R10        | R15        | R20        | R25        |
|---------------------------|------------|------------|------------|------------|------------|------------|
| <b>NR</b>                 | <b>100</b> | <b>100</b> | <b>100</b> | <b>100</b> | <b>100</b> | <b>100</b> |
| <b>ZnO</b>                | <b>4</b>   | <b>4</b>   | <b>4</b>   | <b>4</b>   | <b>4</b>   | <b>4</b>   |
| <b>Stearic acid</b>       | <b>2</b>   | <b>2</b>   | <b>2</b>   | <b>2</b>   | <b>2</b>   | <b>2</b>   |
| <b>S</b>                  | <b>2.5</b> | <b>2.5</b> | <b>2.5</b> | <b>2.5</b> | <b>2.5</b> | <b>2.5</b> |
| <b>TMTD</b>               | <b>0.2</b> | <b>0.2</b> | <b>0.2</b> | <b>0.2</b> | <b>0.2</b> | <b>0.2</b> |
| <b>MBTS</b>               | <b>0.8</b> | <b>0.8</b> | <b>0.8</b> | <b>0.8</b> | <b>0.8</b> | <b>0.8</b> |
| <b>Carbon black (HAF)</b> | <b>50</b>  | <b>50</b>  | <b>50</b>  | <b>50</b>  | <b>50</b>  | <b>50</b>  |
| <b>Aromatic oil</b>       | <b>5</b>   | <b>5</b>   | <b>5</b>   | <b>5</b>   | <b>5</b>   | <b>5</b>   |
| <b>Resin</b>              | <b>0</b>   | <b>5</b>   | <b>10</b>  | <b>15</b>  | <b>20</b>  | <b>25</b>  |

#### 4.4 DETERMINATION OF CURE CHARACTERISTICS

Cure characteristics of the elastomers were determined on a Goettfert Elastograph Model 67.85. It is a microprocessor controlled rotorless cure meter with quick temperature control mechanism and well defined homogeneous temperature distribution in the die. In this instrument a specimen of definite size is kept in the lower half of the cavity which is then oscillated through a small deformation angle ( $0.2^\circ$ ) at a frequency of 50 oscillations per minute. The torque is measured on the lower oscillating disc half. The following data can be taken from the torque - time curve.

- a. **Minimum torque  $M_L$**  - Measure of the stiffness of the unvulcanized test specimen. It is the torque shown by the mix at the test temperature before the onset of cure.
- b. **Maximum torque  $M_H$**  - Measure of the stiffness or shear modulus of the fully vulcanized test specimen at the vulcanization temperature. It is the torque recorded after curing of the mix is completed.
- c. **Scorch time (T10)**- Measure of the time at which vulcanization begins. It is the time taken for attaining 10% of the maximum torque
- d. **Optimum cure time (T90)** – Time taken for attaining 90% of the maximum torque.
- e. **Cure rate index**– Cure rate index is a measure of the rate of vulcanization based on the difference between optimum vulcanization and incipient scorch time. Cure rate index was determined from the following equation  
$$CRI = 100 / (T90 - T10)$$

The Elastograph Microprocessor evaluates the vulcanization curve and prints out the data after each measurement. A typical cure rate curve for NBR is shown below.

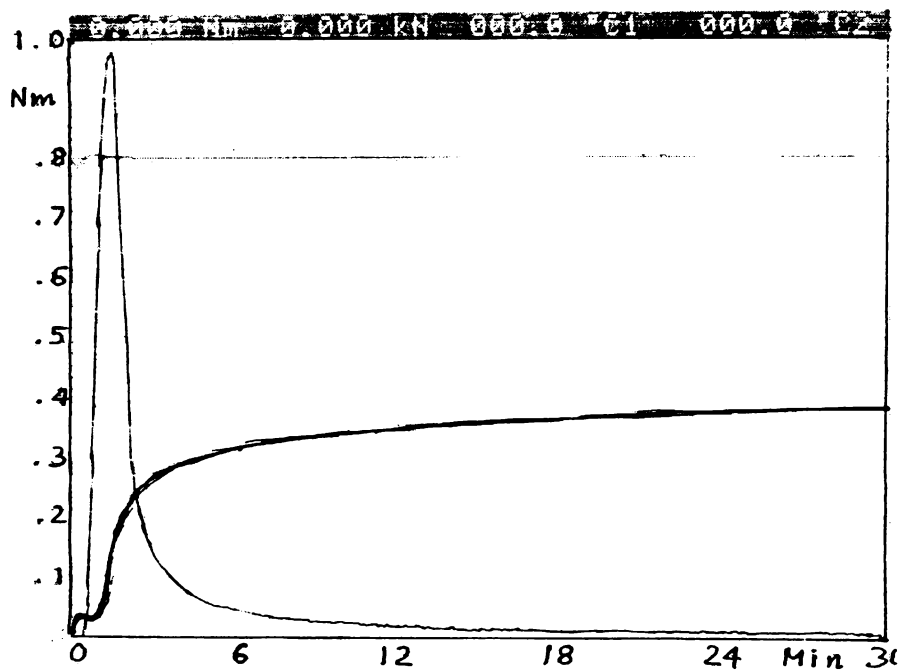

Fig.4.1 Cure rate curve for NBR (Resin content 25 phr, P: F ratio 1:2.9, CNSL:P ratio 1:1)

Tables 4.9 to Table 4.16 show the cure characteristics of different rubber formulations.

**Table 4.9**  
**Vulcanization characteristics of NBR for different resin contents**

| P: F ratio | Resin content | Vulcanization characteristics |                         |                      |                      |
|------------|---------------|-------------------------------|-------------------------|----------------------|----------------------|
|            |               | Scorch time (min)             | Optimum cure time (min) | Minimum torque (N.m) | Maximum torque (N.m) |
| 1: 2.9     | 0             | 1.1                           | 3.5                     | 0.188                | 0.552                |
|            | 5             | 1.13                          | 3.9                     | 0.12                 | 0.62                 |
|            | 10            | 1.15                          | 4.2                     | 0.11                 | 0.43                 |
|            | 15            | 1.14                          | 5.6                     | 0.13                 | 0.311                |
|            | 20            | 1.2                           | 8.5                     | 0.11                 | 0.321                |
|            | 25            | 1.8                           | 12.4                    | 0.027                | 0.3833               |

**Table 4.10**  
**Vulcanization characteristics of NBR for different P: F ratios**

| Resin content | P: F ratio | Vulcanization characteristics |                         |                      |                      |
|---------------|------------|-------------------------------|-------------------------|----------------------|----------------------|
|               |            | Scorch time (min)             | Optimum cure time (min) | Minimum torque (N.m) | Maximum torque (N.m) |
| 25            | 1:2.9      | 1.8                           | 12.4                    | 0.027                | 0.3833               |
|               | 1:2.3      | 0.5                           | 12.42                   | 0.097                | 0.749                |
|               | 1:1.7      | 0.1                           | 11.1                    | 0.13                 | 0.357                |
|               | 1:1.1      | 1.2                           | 12.4                    | 0.1084               | 0.5454               |

**Table 4.11**  
**Vulcanization characteristics of SBR for different CNSL contents**

|       |    | Scorch time (min) | Optimum cure time (min) | Minimum torque (N.m) | Maximum torque (N.m) |
|-------|----|-------------------|-------------------------|----------------------|----------------------|
| 1:2.9 | 0  | 1.2               | 12.1                    | 0.112                | 0.712                |
|       | 5  | 3.8               | 19.5                    | 0.1127               | 0.631                |
|       | 10 | 2.5               | 13.1                    | 0.1933               | 0.6032               |
|       | 15 | 1.8               | 11.9                    | 0.133                | 0.548                |
|       | 20 | 1.6               | 10.7                    | 0.125                | 0.563                |
|       | 25 | 1.1               | 13.9                    | 0.123                | 0.592                |

**Table 4.12**  
**Vulcanization characteristics of SBR for different resin contents**

| P: F ratio | Resin content | Vulcanization characteristics |                         |                      |                      |
|------------|---------------|-------------------------------|-------------------------|----------------------|----------------------|
|            |               | Scorch time (min)             | Optimum cure time (min) | Minimum torque (N.m) | Maximum torque (N.m) |
| 1:2.9      | 0             | 1.2                           | 12.1                    | 0.112                | 0.712                |
|            | 5             | 1.4                           | 13.4                    | 0.12                 | 0.61                 |
|            | 10            | 1.5                           | 14.2                    | 0.13                 | 0.54                 |
|            | 15            | 1.1                           | 13.2                    | 0.12                 | 0.61                 |
|            | 20            | 1.3                           | 14.5                    | 0.11                 | 0.59                 |
|            | 25            | 1.6                           | 15.2                    | 0.12                 | 0.512                |

**Table 4.13**  
**Vulcanization characteristics of SBR for different P: F ratios**

| Resin content | P: F ratio | Vulcanization characteristics |                         |                      |                      |
|---------------|------------|-------------------------------|-------------------------|----------------------|----------------------|
|               |            | Scorch time (min)             | Optimum cure time (min) | Minimum torque (N.m) | Maximum torque (N.m) |
| 25            | 1:2.9      | 1.6                           | 15.2                    | 0.12                 | 0.512                |
|               | 1:2.3      | 1.1                           | 3.2                     | 0.1406               | 0.6464               |
|               | 1:1.7      | 1.5                           | 4.1                     | 0.1025               | 0.6406               |
|               | 1:1.1      | 1.2                           | 2.2                     | 0.1377               | 0.6792               |

**Table 4.14**  
**Vulcanization characteristics of CR for different resin contents**

| P: F ratio | Resin content | Vulcanization characteristics |                         |                      |                      |
|------------|---------------|-------------------------------|-------------------------|----------------------|----------------------|
|            |               | Scorch time (min)             | Optimum cure time (min) | Minimum torque (N.m) | Maximum torque (N.m) |
| 1:2.9      | 0             | 0.20                          | 9.4                     | 0.16                 | 0.99                 |
|            | 5             | 0.12                          | 10.3                    | 0.12                 | 0.719                |
|            | 10            | 0.16                          | 11.1                    | 0.11                 | 0.729                |
|            | 15            | 0.16                          | 11.7                    | 0.12                 | 0.610                |
|            | 20            | 0.11                          | 12.2                    | 0.13                 | 0.629                |
|            | 25            | 0.20                          | 13.2                    | 0.12                 | 0.52                 |

**Table 4.15**  
**Vulcanization characteristics of EPDM for different resin contents**

| P: F ratio | Resin content | Vulcanization characteristics |                         |                      |                      |
|------------|---------------|-------------------------------|-------------------------|----------------------|----------------------|
|            |               | Scorch time (min)             | Optimum cure time (min) | Minimum torque (N.m) | Maximum torque (N.m) |
| 1:2.9      | 0             | 0.20                          | 14.4                    | 0.111                | 0.290                |
|            | 5             | 0.12                          | 14.54                   | 0.122                | 0.245                |
|            | 10            | 0.13                          | 13.1                    | 0.121                | 0.294                |
|            | 15            | 0.14                          | 12.4                    | 0.111                | 0.290                |
|            | 20            | 0.20                          | 20                      | 0.144                | 0.394                |
|            | 25            | 0.13                          | 20.4                    | 0.132                | 0.194                |

**Table 4.16**  
**Vulcanization characteristics of IIR for different resin contents**

| P: F ratio | Resin content | Vulcanization characteristics |                         |                      |                      |
|------------|---------------|-------------------------------|-------------------------|----------------------|----------------------|
|            |               | Scorch time (min)             | Optimum cure time (min) | Minimum torque (N.m) | Maximum torque (N.m) |
| 1:2.9      | 0             | 0.5                           | 5.6                     | 0.262                | 0.4267               |
|            | 5             | 1.3                           | 7.9                     | 0.054                | 0.6152               |
|            | 10            | 1.3                           | 11.8                    | 0.061                | 0.611                |
|            | 15            | 1.55                          | 14                      | 0.05                 | 0.541                |
|            | 20            | 1.65                          | 13                      | 0.03                 | 0.550                |
|            | 25            | 1.54                          | 14.2                    | 0.06                 | 0.452                |

**Table 4.17**  
**Vulcanization characteristics of NR for different resin contents**

| P: F ratio | Resin content | Vulcanization characteristics |                         |                      |                      |
|------------|---------------|-------------------------------|-------------------------|----------------------|----------------------|
|            |               | Scorch time (min)             | Optimum cure time (min) | Minimum torque (N.m) | Maximum torque (N.m) |
| 1:2.9      | 0             | 0.3                           | 12                      | 0.1                  | 1.18                 |
|            | 5             | 0.4                           | 14.3                    | 0.21                 | 0.9462               |
|            | 10            | 0.5                           | 12.4                    | 0.182                | 1.11                 |
|            | 15            | 0.6                           | 11.3                    | 0.244                | 0.9462               |
|            | 20            | 1.1                           | 14.4                    | 0.15                 | 1.1                  |
|            | 25            | 1.2                           | 12.8                    | 0.1914               | 1.109                |

#### **4.5 MOULDING AND SAMPLE PREPARATION**

Initially cure characteristics of the mixes were determined at 150°C on a Goettfert Elastograph (Model 67.85). Vulcanization to optimum cure time was then carried out in an electrically heated hydraulic press with 30 cm x 30 cm platens and 13.72 MPa at 150°C. Mouldings were cooled quickly in water at the end of the curing cycle and stored in a cold and dark place for subsequent physical testing. From the vulcanized sheets dumb-bell specimens and angular specimens were punched out.

#### **4.6 AGEING STUDIES**

Oxidative ageing tests were carried out as per ASTM D573-88 (27) procedure, using an oven at 100°C. Specimens were subjected to ageing for 1, 2, 3, 4, 5, 6, 7, 8, 9 and 10 days. Physical properties of the specimens before and after ageing were determined after 24 hours of conditioning at ambient temperature.

#### 4.7 TESTING

##### a. Tensile strength, elongation at break and modulus (ASTM (D 412-98 a) (28).

From the vulcanized sheet dumb-bell shaped specimens were punched and were tested on a Zwick tensile testing machine. The crosshead speed was maintained at 500 mm/minute.

##### b. Tear strength

This was carried out according to the standard ASTM D 624-00 (29) using angular specimens punched out from compression moulded sheets. Throughout the test the rate of the grip was kept at 500 mm/min.

##### c. Miscellaneous tests

1. **Compression tests**- ASTM D 395-03 (30) was used for the compression test. Test specimens were compressed for 22 hours at 70<sup>0</sup>C in an air oven and the final thickness was measured 30 minutes after removal from the clamp.
2. **Durometer hardness** – Hardness of the samples was measured by means of Shore A Durometer according to ASTM D 676-86 (31)
3. **Abrasion resistance**- Abrasion resistance was measured using a DIN Abrader as per DIN 53516 with a load of 5N. (32)
4. **Swelling index**- Swelling index was measured as per ASTM D 3616-95 (33). 0.5 g of the vulcanizate was kept in toluene for 20 hours. Samples were taken out, quickly dried with a filter paper and the swollen weight was found. The swollen samples were dried in a vacuum oven at 60<sup>0</sup>C for 12 hours and the deswollen weight was noted.

Swelling index = (swollen weight- deswollen weight) /mass of dried gel

Gel % = mass of gel x 100/ initial weight

5. **Density**- density of the vulcanizate was determined according to ASTM D 297-93 (34)



6. **Acetone soluble matter-** Acetone soluble matter was determined as per ASTM D 297-93 (2002) (34). Approximately 2 gm of the sample was cut into strips and extracted with acetone for 16 hours using extraction apparatus at 70<sup>0</sup>C and then dried at 70<sup>0</sup>C for 2 hours.

Acetone soluble matter, % = gms of extract x 100/gm of specimen.

7. **Toluene soluble matter-** was determined by extracting the sample with toluene for 24 hours.

Toluene soluble matter = gms of extract x 100/ gm of specimen.

#### 4.8 REACTION OF PHENOLIC RESIN WITH ELASTOMERS (35)

Three types of chemical reactions are possible during the curing of rubber in the presence of phenolic resin - self-hardening of phenolic resin, crosslinking of phenolic resin with rubber and vulcanization of rubber.

There are two possible mechanisms for resin cure of unsaturated rubbers- The 'chroman mechanism' and 'allyl hydrogen mechanism'

##### (1) The chroman mechanism

###### a. Formation of quinone methide

At high temperature water is eliminated from the resin leading to the formation of a quinone methide.

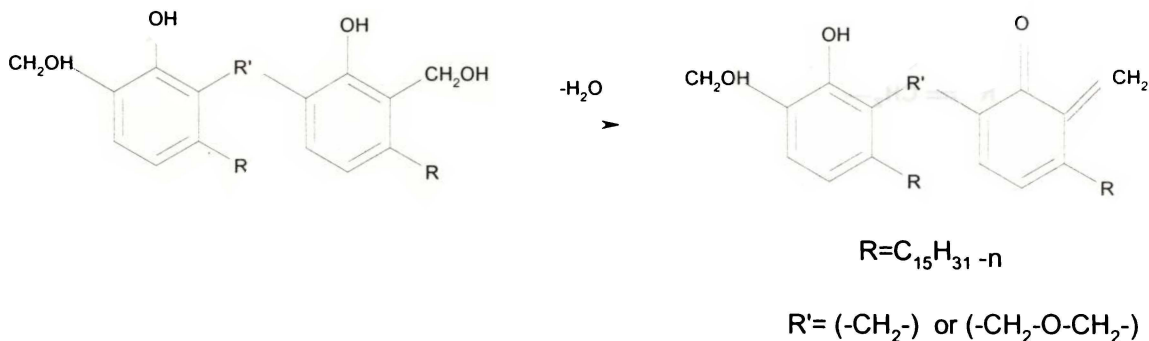

**Fig. 4.2 Formation of quinone intermediate**

6. **Acetone soluble matter**- Acetone soluble matter was determined as per ASTM D 297-93 (2002) (34). Approximately 2 gm of the sample was cut into strips and extracted with acetone for 16 hours using extraction apparatus at 70°C and then dried at 70°C for 2 hours.

Acetone soluble matter, % = gms of extract x 100/gm of specimen.

7. **Toluene soluble matter**- was determined by extracting the sample with toluene for 24 hours.

Toluene soluble matter = gms of extract x 100/ gm of specimen.

#### 4.8 REACTION OF PHENOLIC RESIN WITH ELASTOMERS (35)

Three types of chemical reactions are possible during the curing of rubber in the presence of phenolic resin - self-hardening of phenolic resin, crosslinking of phenolic resin with rubber and vulcanization of rubber.

There are two possible mechanisms for resin cure of unsaturated rubbers- The 'chroman mechanism' and 'allyl hydrogen mechanism'

##### (1) The chroman mechanism

###### a. Formation of quinone methide

At high temperature water is eliminated from the resin leading to the formation of a quinone methide.

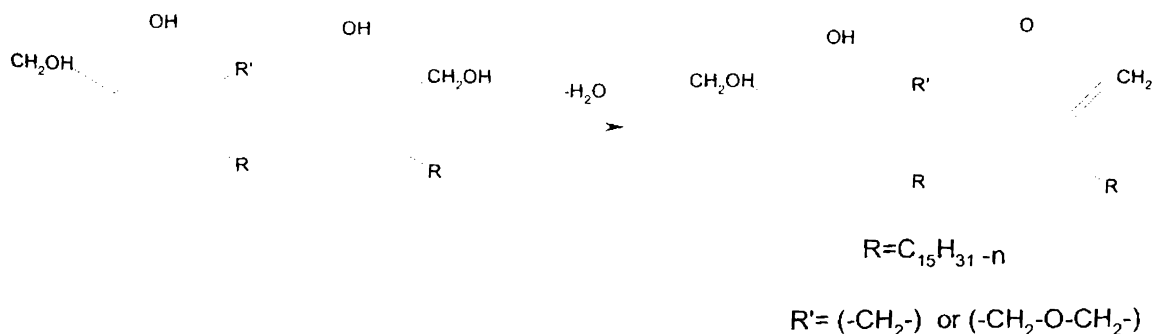

**Fig. 4.2 Formation of quinone intermediate**

b. Reaction between quinone intermediate and rubber

The quinone intermediate combines with a rubber double bond in a 1,4-cycloaddition (Diels-Alder type) reaction to give a product with a chroman structure. Subsequent dehydration and a second addition of a molecule of rubber give the crosslinked product.

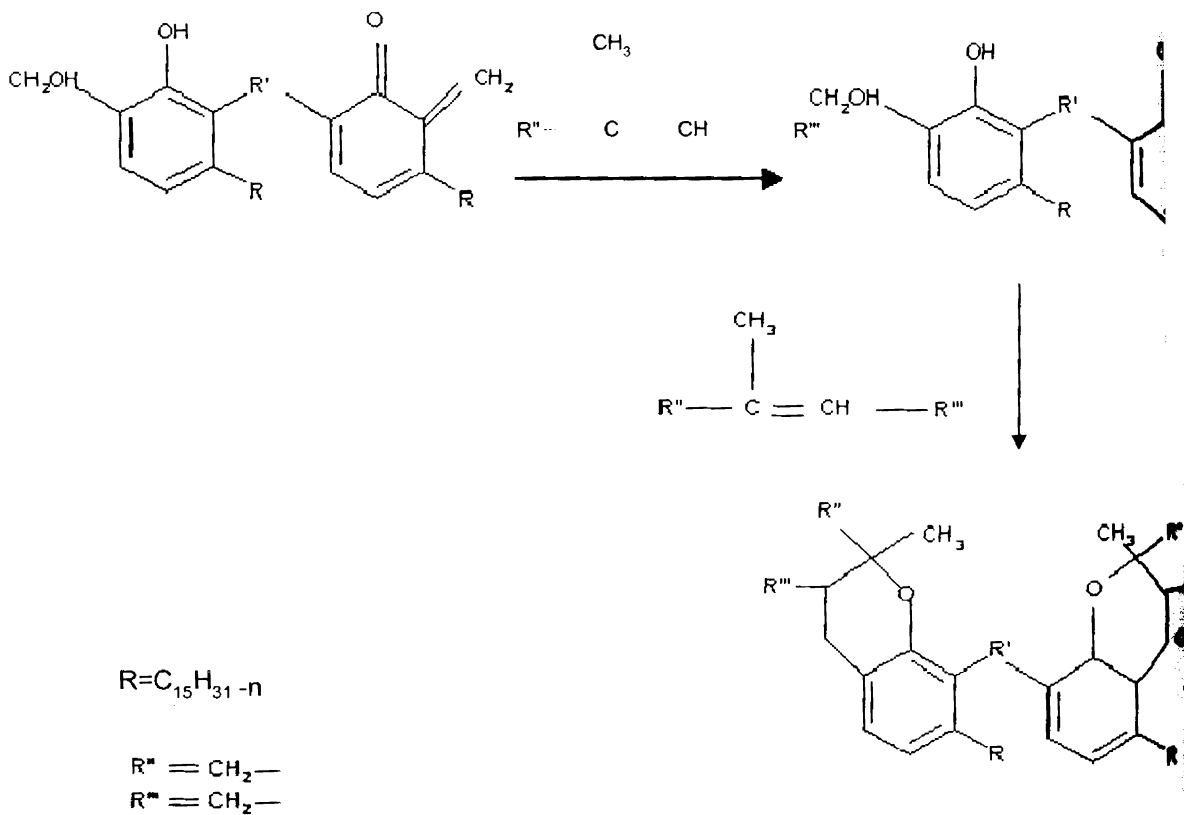
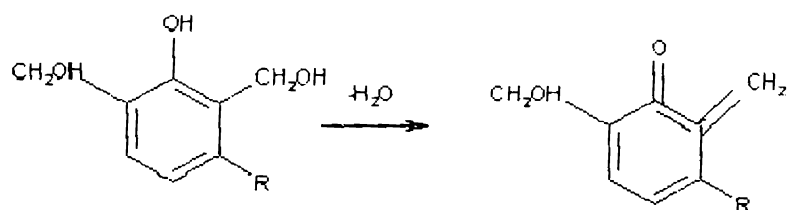

Fig. 4.3 Reaction of phenolic resin with elastomers (Chroman mechanism)

**(2) The allyl hydrogen mechanism**

a. Formation of quinone methide



**Fig.4.4 Formation of quinone intermediate**

b. Reaction of quinone intermediate and rubber

O-methylene quinone abstracts an allyl hydrogen from the unsaturated rubber.

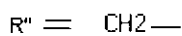
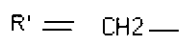
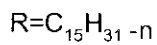
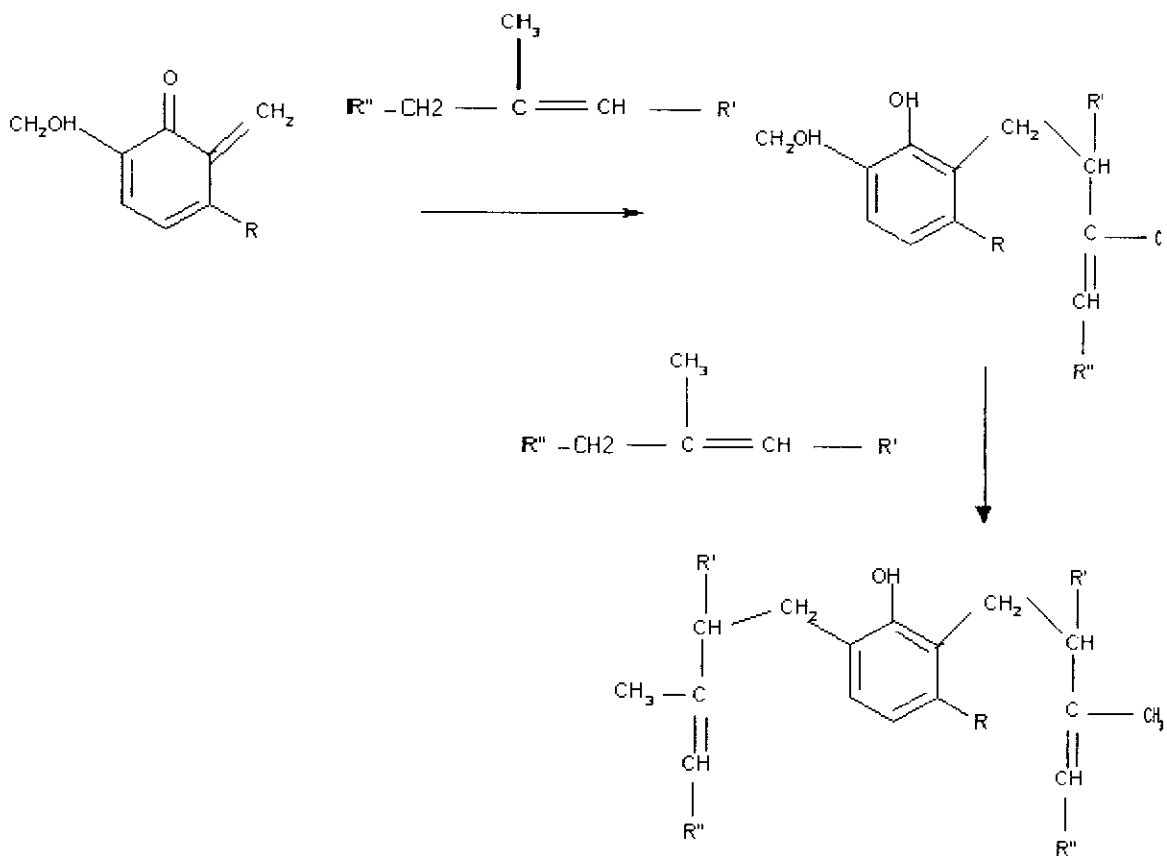

**Fig. 4.5 Reaction of phenolic resin with elastomers (Allyl hydrogen mechanism)**

### c. Reaction between NBR and phenolic resin (36)

In the case of NBR,  $C \equiv N$  undergoes a different reaction with PF resin.

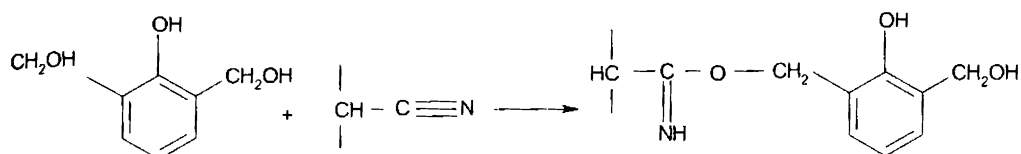

Fig. 4.6 Reaction between NBR and phenolic resin

Sulphur crosslinking of the monomeric units also usually happens along with resin crosslinking.

In this study, the effect of incorporation of the resin into various elastomers has been investigated in terms of the retention of mechanical and other physical properties.

## 4.9 RESULTS AND DISCUSSION

The resin prepared by the condensation of CNSL- phenol- formaldehyde (Section 2.3) was added to various elastomers to observe the effect on elastomer ageing properties. Different proportions of the resin were milled into each rubber compound during the mixing process. The properties of the resin cured rubber after various periods of ageing at 100<sup>0</sup>C were evaluated and compared to investigate the role of the resin in improving the ageing properties.

In the case of SBR and NBR a more exhaustive study was conducted in order to understand the effect of stoichiometry of the resin on the properties of the vulcanizates.

### 4.9.1 NBR- Effect of resin on the ageing properties of vulcanizate

#### a. Resin content

##### 1. Effect of resin content on the properties of vulcanizates

In this study resin with P: F ratio 1: 2.9 and CNSL: P 1: 1 is used.

### 1. Tensile strength

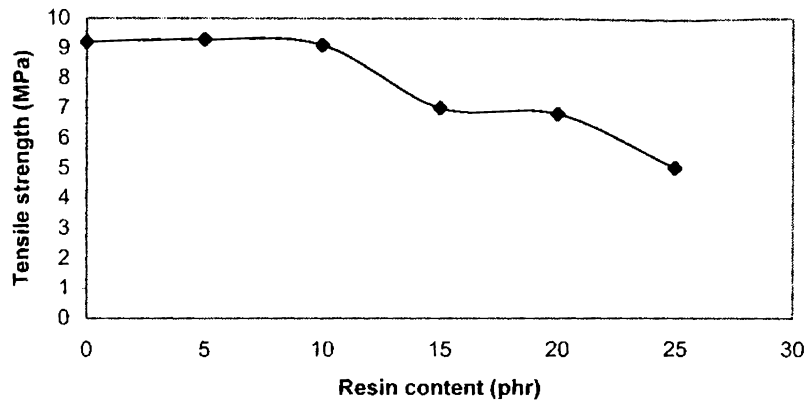

**Fig. 4.7 Variation of tensile strength with resin content of NBR**

Fig. 4.7 shows the variation of tensile strength with resin content on NBR. Addition of resin decreases the tensile strength of NBR vulcanizates. This tendency increases as the resin content goes up. The reduction in tensile strength as the resin content increases can be attributed to the plasticization effect of the resin (37) or the slow rate of crosslinking reaction involving the rubber and resin (38).

### 2. Elongation at break

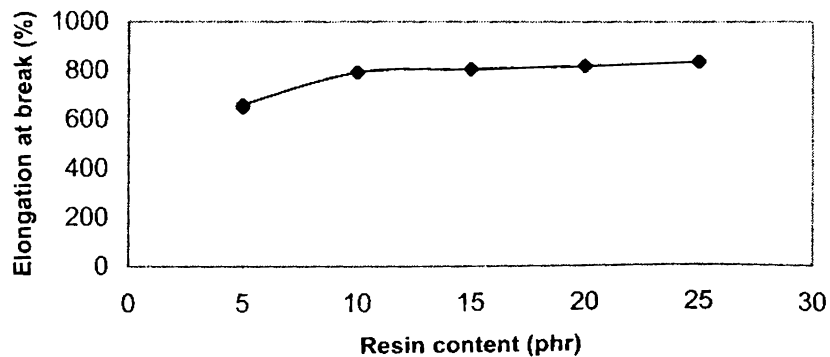

**Fig. 4.8 Variation of elongation at break with resin content of NBR**

Fig. 4.8 shows the effect of addition of resin on the elongation at break of vulcanizates. Elongation at break shows a marginal increase as resin content increases.

### 3. Modulus

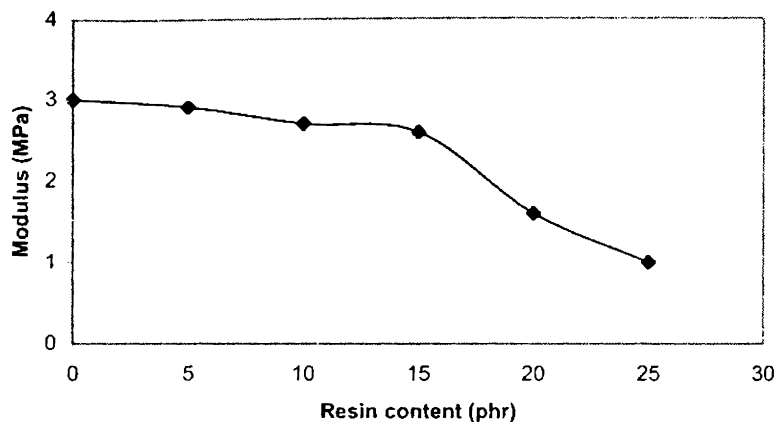

**Fig. 4.9 Variation of modulus with resin content of NBR**

Fig. 4.9 shows the variation of modulus with resin content. As resin content increases modulus decreases. Possibly the long side chain of CNSL gives flexibility to the vulcanizates and reduces the modulus.

### 4. Tear strength

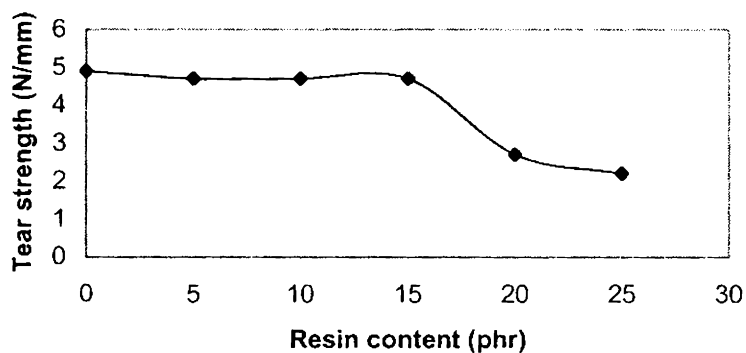
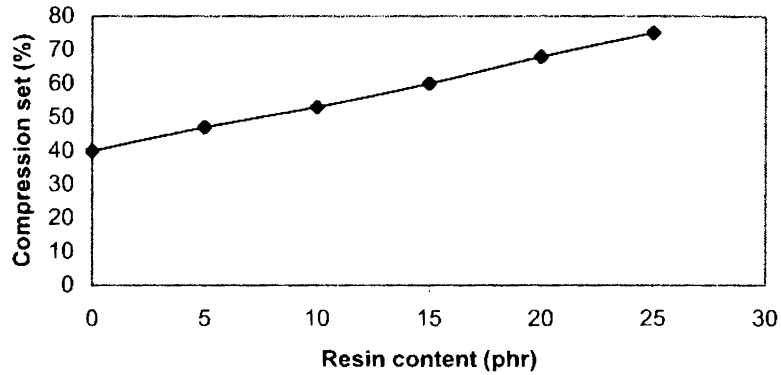

**Fig. 4.10 Variation of tear strength with resin content of NBR**

Fig. 4.10 shows the effect of addition of resin on tear strength of NBR vulcanizates. Tear strength decreases as resin content increases from 15 phr onwards. The resin can lead to reduction in crystallinity which is one of the factors



### 5. Compression set



**Fig. 4. 11 Variation of compression set with resin content of NBR**

Compression set increases linearly with resin content (Fig 4.11). Compression set indicates loss of elasticity and resilience of the rubber. The presence of the resin is responsible for this.

### 6. Swelling index

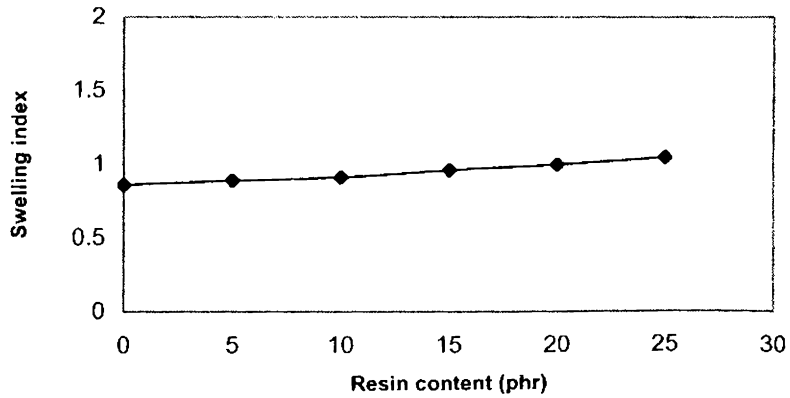

**Fig. 4.12 Variation of swelling index with resin content of NBR**

The effect of resin content on swelling index is shown in Fig 4.12. The swelling index is seen to increase only slightly with increase in resin content.

### 7. Abrasion loss

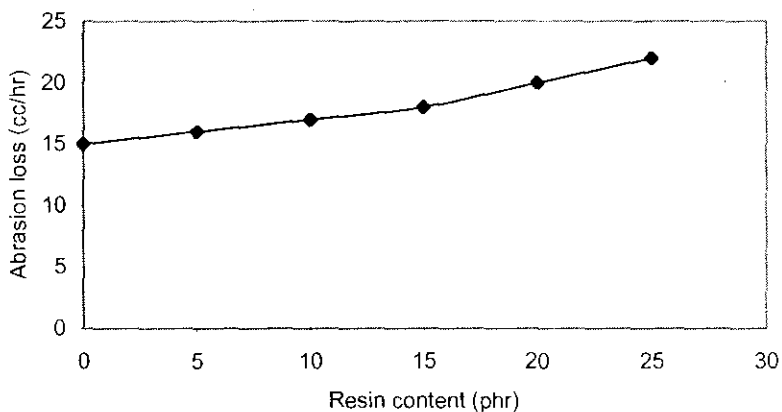

Fig. 4.13 Variation of abrasion loss with resin content of NBR

Variation of abrasion loss with resin content is shown in Fig 4.13. Abrasion loss values increase with increase in resin content which can be due to higher percentages of uncrosslinked material at higher resin percentages.

### 8. Acetone soluble matter

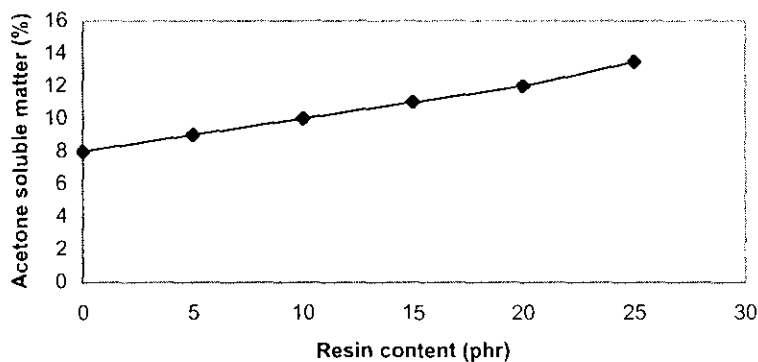
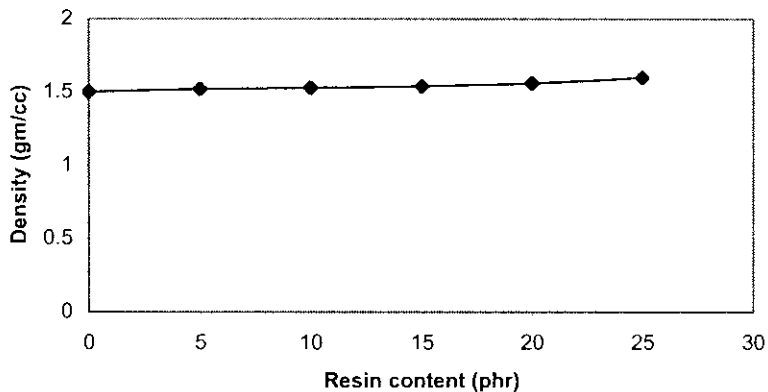

Fig. 4.14 Variation of acetone soluble matter with resin content of NBR

Acetone soluble matter increases as resin content increases. Acetone soluble matter is the uncrosslinked resin present in the rubber. At higher percentages of resin the acetone extractable matter is naturally more (Fig. 4.14).

## 9. Density



**Fig. 4.15** Variation of density with resin content of NBR

As the resin content increases, the average density goes up marginally as can be expected.

## II. Effect of resin content on ageing properties of NBR vulcanizates using Formulation I.

In this study resin with P: F ratio 1: 2.9 and CNSL: P 1:1 is used.

### 1. Tensile strength

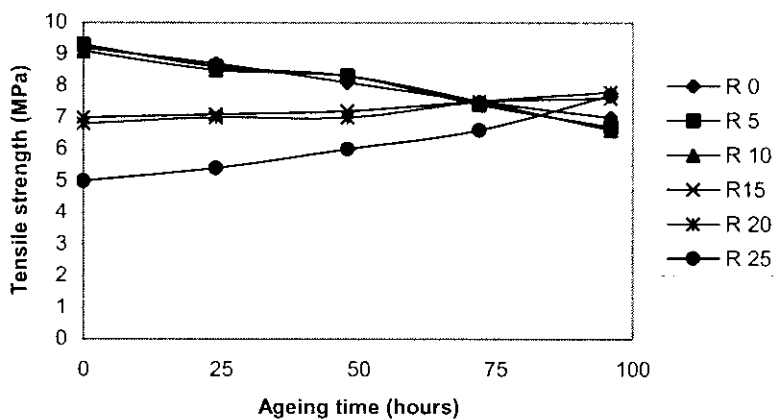

**Fig. 4.16** Variation of tensile strength with resin content for NBR vulcanizates.

Fig. 4.16-4.18 show the effect of ageing for different periods (24 hours, 48 hours, 72 hours and 96 hours) on mechanical properties of the vulcanizate containing different percentages of the resin as ageing stabilizer using Formulation I. Referring to Fig 4.16 tensile strength of samples containing lower percentages of the resin (0-10 phr) decreases steadily as the ageing period increases. But for higher resin samples (15-25 phr) tensile strength after ageing shows an increasing tendency. After 96 hours ageing the tensile strength for the high resin samples are marginally higher. Beyond 96 hours, the high resin samples may gain strength further. It is likely that rubber- resin interactions will continue to take place as the ageing process continues. This may be attributable to the post curing reactions taking place in the vulcanizate during the ageing period, resulting in additional crosslinks and leading to an increase in cross link density (39, 40).

## 2. Elongation at break

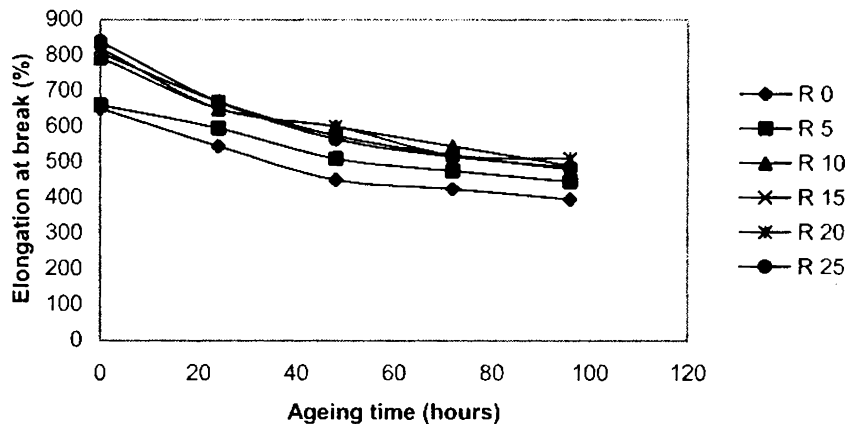
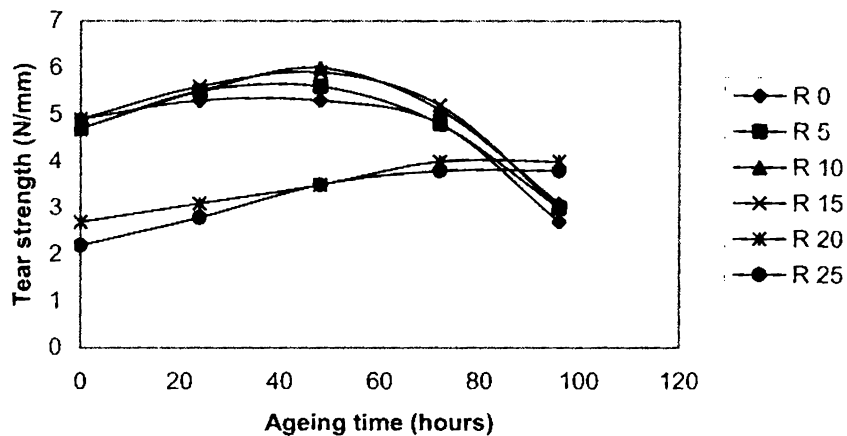

Fig. 4.17 Variation of elongation at break with resin content for NBR vulcanizates.

The elongation at break (Fig. 4.17) is comparatively high for the high resin samples. But as the ageing period increases the fall in elongation at break is steeper for the high resin samples. Rubber-resin interactions causes a gradual fall in elongation as ageing proceeds.

### 3. Tear strength



**Fig. 4.18** Variation of tear strength with resin content for NBR vulcanizates

Fig. 4.18 shows the effect of ageing on tear strength of samples containing various percentages of resin. Here again, at higher percentages of the resin the tear strength steadily increases with ageing period. After about 50 hours ageing there is a fall in tear strength in the case of low resin samples.

It is clear that the crosslinking process proceeds at an extremely slow rate. The positive effect of incorporation of the resin is noticeable only beyond 20 phr resin. Ageing studies leading to prolonged periods are necessary to establish long term ageing properties. The age stabilization can be attributed to slow crosslinking reactions involving the resin and the rubber which take more than 96 hours for completion.

#### b. P: F ratio of resin

In this study resin with CNSL: P ratio 1:1 and resin content of 25 phr and P:F ratios 1:2.9, 1: 2.3, 1:1.7 and 1:1.1 were used.

The moulding studies using the first formulation was modified by reducing the filler content because the compound become very sticky during mixing. So for the following cases Formulation II was used.

### 1. Tensile strength

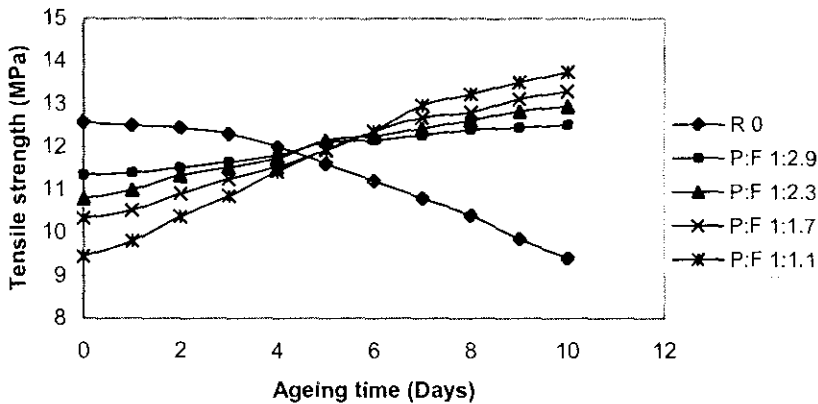

**Fig. 4.19 Variation of tensile strength with ageing time of NBR vulcanizates containing resin with different P: F ratios**

Fig. 4.19 shows the variation of tensile strength with ageing time of samples containing P: F ratios, 1: 2.9, 1:2.3, 1:1.7 and 1:1.1.

The immediate effect of adding the resin was to lower the tensile strength of the unaged material. This can be attributed either to the slow curing nature of the resin or to the slow rate of cross-linking reaction involving the resin and rubber. The tensile strength of the vulcanizate without added resin decreased with ageing time. The reduction in tensile strength may have been caused by a decrease in the number of polysulfidic crosslinks and an increase in the number of monosulfidic ones, or by network disruption resulting from backbone chain scission and crosslink rupture (12- 15). Each backbone scission creates two chain end segments attached to the network at one end. These segments have non-load-bearing effects and can be expected to lower the strength.

The tensile strength of vulcanizates containing resin increased with ageing time. This points to the formation of additional network chains resulting from crosslinking between the resin and the NBR (39,40). The increase in tensile

strength during ageing is most obvious for vulcanizates with P: F ratio 1:1.1. The improvement of properties on ageing was more pronounced when a resin containing a relatively low amount of formaldehyde was used. The shape of the tensile strength curves when resin is added is typical of resin cured systems. From the standpoint of the stability of properties on ageing, a resin with P: F ratio 1: 2.9 can be considered the best, as the change in tensile strength was least. Such a resin completes its reaction with rubber at an early stage of ageing, hence the high initial tensile strength values.

## 2. Elongation at break

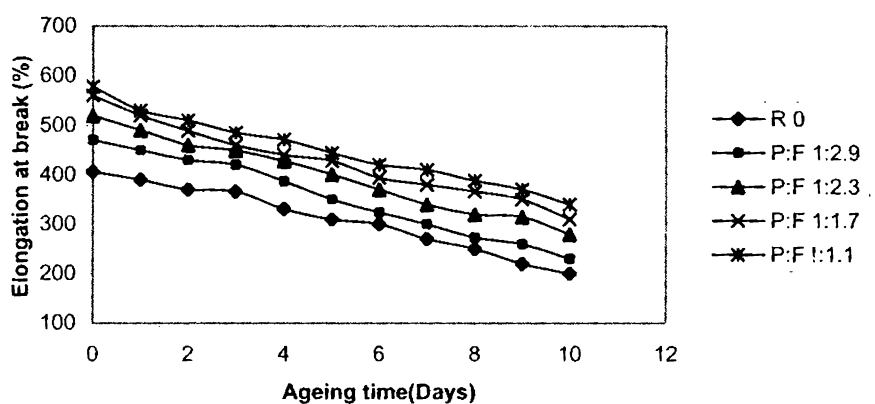

**Fig. 4.20** Variation of elongation at break with ageing time of NBR vulcanizates containing resin with different P: F ratios

Fig. 4.20 shows the variation in elongation at break with ageing time of samples containing P: F ratios 1: 2.9, 1: 2.3, 1: 1.7 and 1: 1.1. There was a general increase in elongation at break on addition of the resin. The effect was greater for resins containing less formaldehyde. This can again be attributed to the smaller size of the molecules when more formaldehyde was present. However, in all cases there was a steady reduction in elongation at break on ageing suggesting a more crosslinked structure.

### 3. Modulus

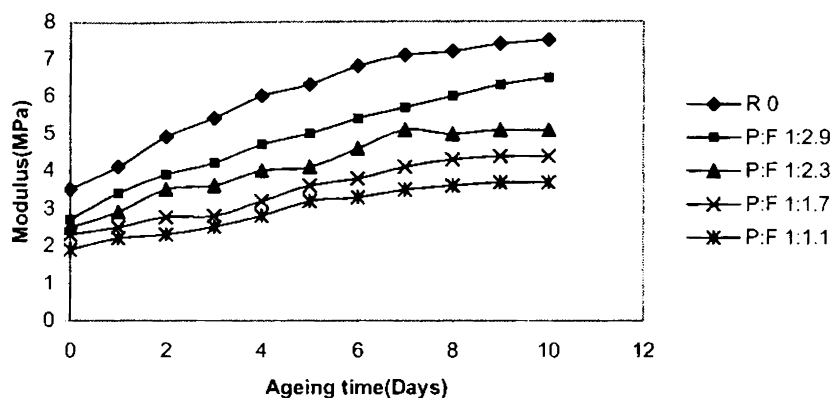

**Fig. 4.21 Variation of Modulus with ageing time of NBR vulcanizates containing resin with different P: F ratios**

The tensile modulus was also lower for unaged samples containing resin than for those without resin. As the ageing time increased the modulus increased for all the samples (Fig. 4.21). This could have been due to the stiffening of the vulcanizate as ageing proceeds. The resin with a P: F ratio of 1: 2.9 showed the greatest effect. Interestingly, samples without resin also showed increasing modulus on ageing. Stiffening due to degradation can be the reason for this.

### 4. Tear strength

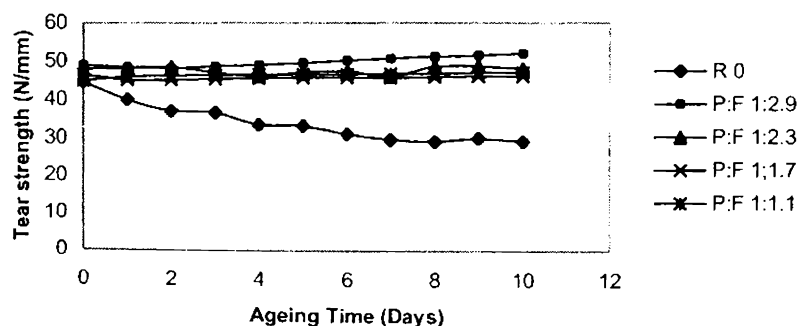
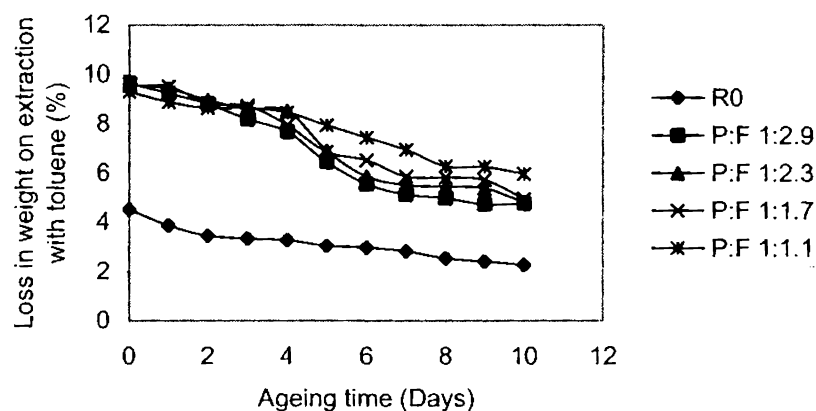

**Fig. 4.22 Variation of tear strength with ageing time of NBR vulcanizates containing resin with different P: F ratios**



Fig. 4.22 shows the variation in tear strength. The tear strength of the samples without any resin decreased with ageing time and that of samples containing resin showed very little change. Resins containing more formaldehyde showed marginally higher tear strength. The resin with a P: F ratio 1:2.9 gave the best protection against a reduction in tear strength.

### 5. Loss in weight on extraction with toluene



**Fig. 4.23 Variation of loss in weight on extraction with toluene of NBR vulcanizates containing resin with different P: F ratios**

Fig. 4.23 shows the variation of loss in weight on extraction with toluene for vulcanizates with different P: F ratios. The extent of matter soluble in toluene decreased with ageing time for vulcanizates containing resin due to the formation of additional crosslinks in the vulcanizates. In general, extractable matter, rubber or resin, is more in samples containing resin. There is very little change in extractable matter with formaldehyde content.

## 6. Swelling index

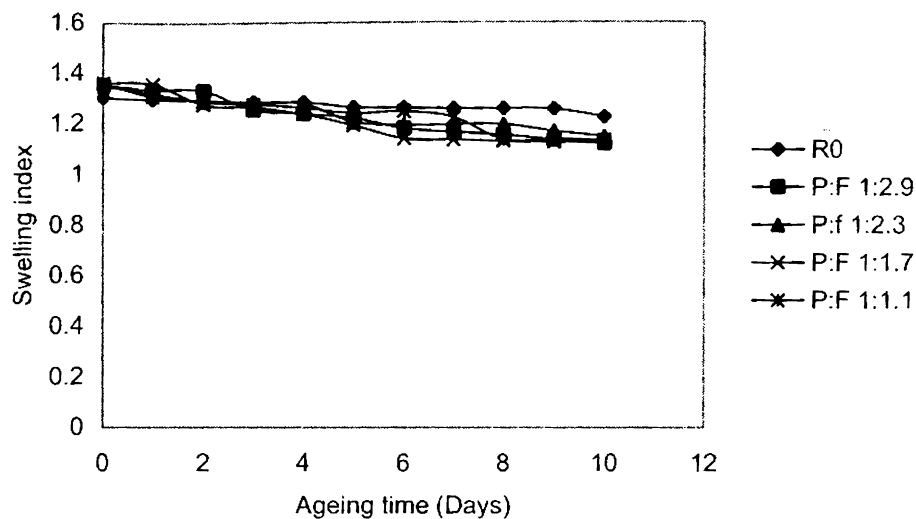

**Fig. 4.24 Variation of swelling index of NBR vulcanizates containing resin with different P: F ratios**

Fig. 4.24 shows the variation of swelling index. Swelling index decreases as ageing time increases. As formaldehyde content changes, there is very little change in swelling index.

7. Loss in weight on extraction with acetone

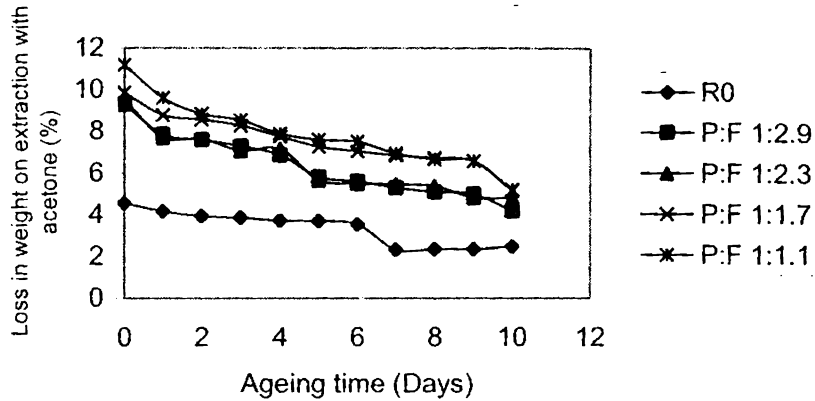

Fig. 4.25 Variation of loss in weight on extraction with acetone of NBR vulcanizates containing resin with different P: F ratios

Fig. 4.25 shows the variation of loss in weight on extraction with acetone. Acetone soluble matter is more in vulcanizates containing resin. There is not much change in weight on extraction with acetone with formaldehyde content.

c. CNSL: P ratio

1. Tensile strength

In this study resin with P: F ratio 1: 2.9 and resin content 25 phr was used.

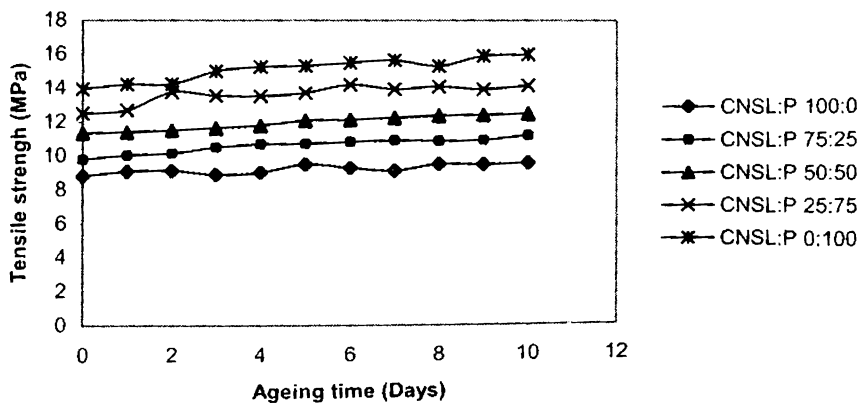

Fig. 4.26 Variation of tensile strength with ageing time of NBR vulcanizates containing resin with different CNSL: P ratios

Fig. 4.26 shows the variation in tensile strength. The tensile strength of the samples showed only a marginal increase with ageing time. As the CNSL content increased the tensile strength of the vulcanizates decreased. CNSL is less reactive than phenol. Crude CNSL also contains constituents that may not react with formaldehyde. The structure of CNSL is less conducive to a compact crosslinked structure in comparison with phenol. For these reasons, increasing amounts of CNSL leads to lowering of tensile strength.

## 2. Elongation at break

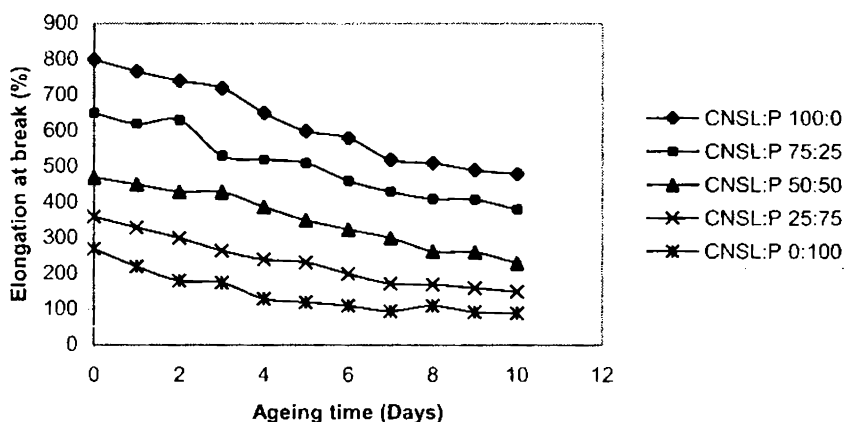
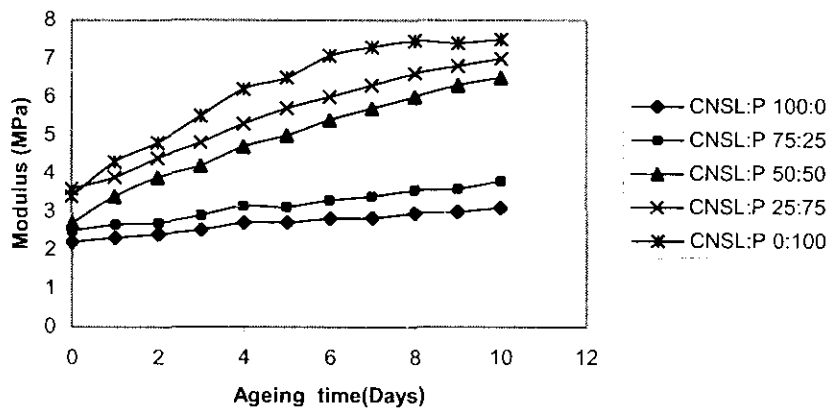

Fig. 4.27 Variation of elongation at break with ageing time of NBR vulcanizates containing resin with different CNSL: P ratios

Fig. 4.27 shows the variation in elongation at break. As the CNSL content increased, the elongation at break increased. The long aliphatic chain of the CNSL molecule leads to higher plasticity. Hence samples containing more CNSL show greater elongation. Ageing has the effect of reducing the elongation of all samples.

### 3. Modulus



**Fig. 4.28** Variation of tensile modulus with ageing time of NBR vulcanizates containing resin with different CNSL: P ratios

Fig. 4.28 shows the variation in tensile modulus. As the CNSL content increased, the modulus decreased. This may be due to the long side chain of CNSL, which can create steric hindrance to the crosslinking reaction. Ageing improves the modulus in all cases although to a lesser extent when more CNSL is present.

### 4. Tear strength

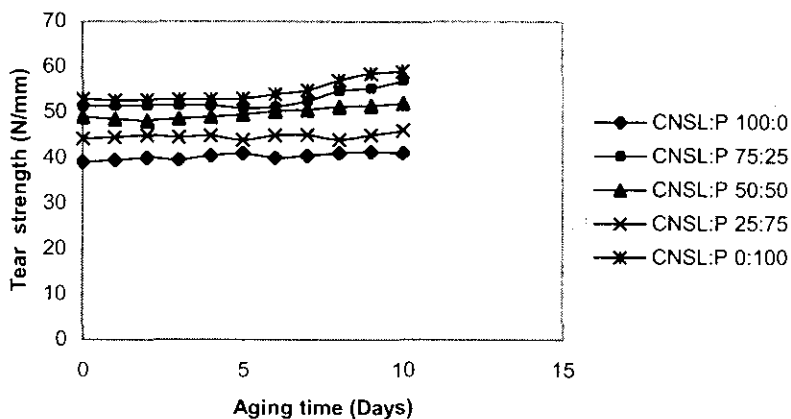

**Fig. 4.29** Variation of tear strength with ageing time of NBR vulcanizates containing resin with different CNSL: P ratios

Fig. 4.29 shows the variation in tear strength with ageing time of vulcanizates with different CNSL: P ratios. There is a general but slight increase in tear strength on ageing. As CNSL content increased, the tear strength decreased. This could have been due to the lower reactivity of CNSL due to the presence of side chain.

### 5. Loss in weight on extraction with toluene

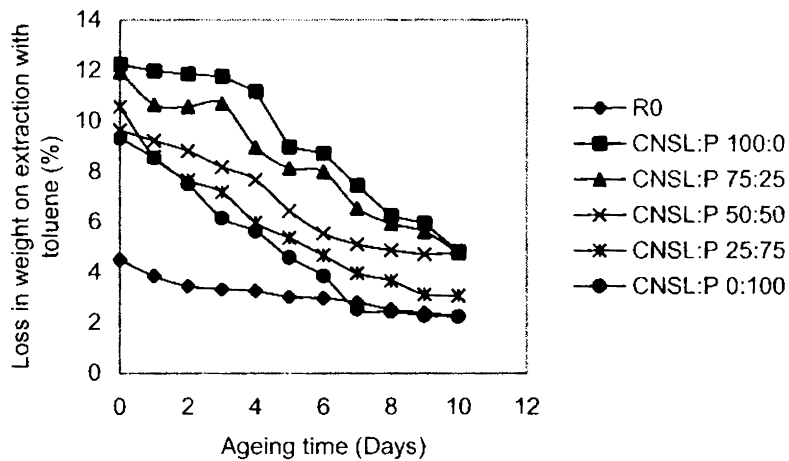

**Fig. 4.30 Variation of loss in weight on extraction with toluene with ageing time of NBR vulcanizates containing resin with different CNSL: P ratios**

Fig. 4.30 shows the variation of loss in weight on extraction with toluene of NBR vulcanizates with different CNSL: P ratios. As CNSL content increases the extent of matter soluble in toluene increases. The compactness of the vulcanizate decreases due to the long side chain of CNSL. Matter soluble in toluene decreased with increases ageing time due to progressive crosslinking between resin and rubber

### 6. Swelling index

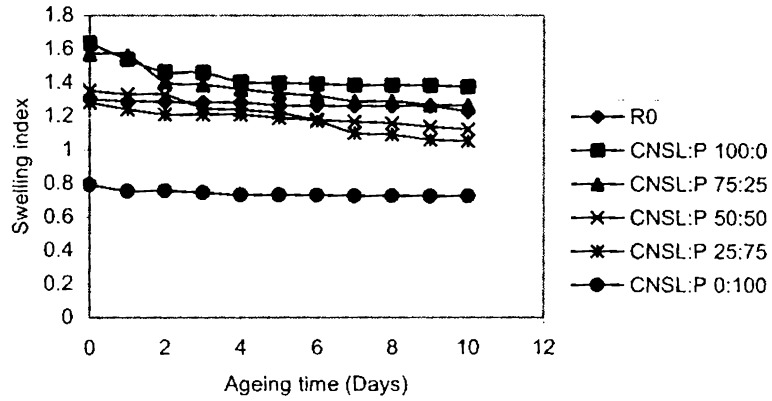

**Fig. 4.31 Variation of swelling index with ageing time of NBR vulcanizates containing resin with different CNSL: P ratios**

Fig. 4.31 shows the variation of swelling index. As CNSL content increases swelling index increases.

### 7. Loss in weight on extraction with acetone

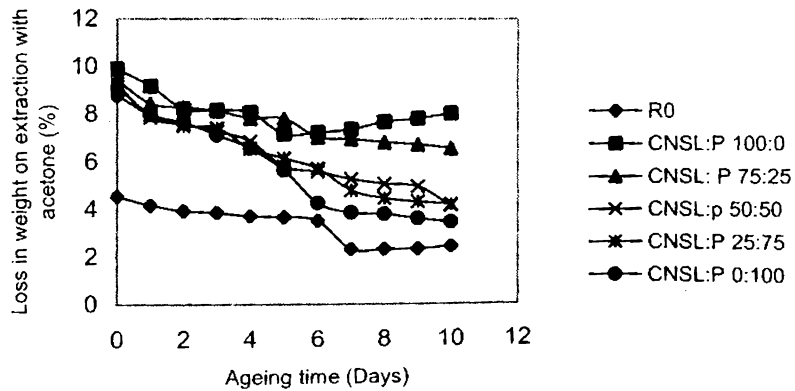

**Fig. 4.32 Variation of loss in weight on extraction with acetone with ageing time of NBR vulcanizates containing resin with different CNSL: P ratios**

Fig. 4.32 shows the variation of loss in weight on extraction with acetone. Loss in weight on extraction with acetone decreases as ageing time increases. More and more of the resin get incorporated in the vulcanizate as ageing time increases. As CNSL content increases, matter soluble in acetone increases. This is due to the unreacted CNSL present in the vulcanizate at high CNSL contents.

#### 4.9.2 SBR- Effect of resin on the ageing properties of vulcanizates.

##### a. CNSL Content.

##### 1. Tensile strength

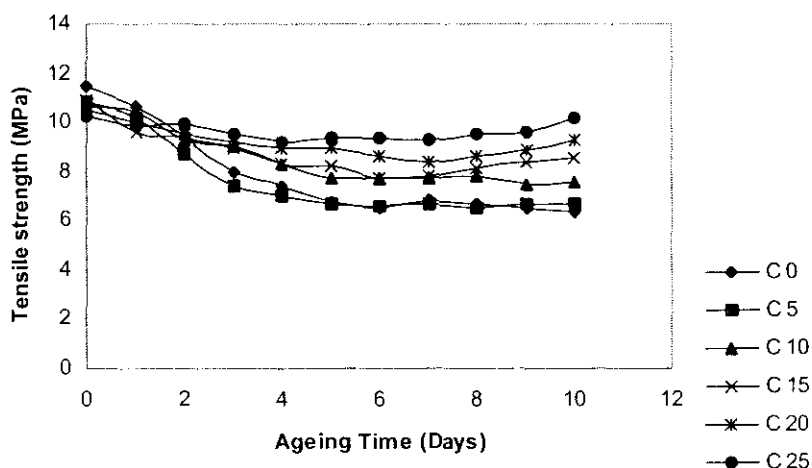
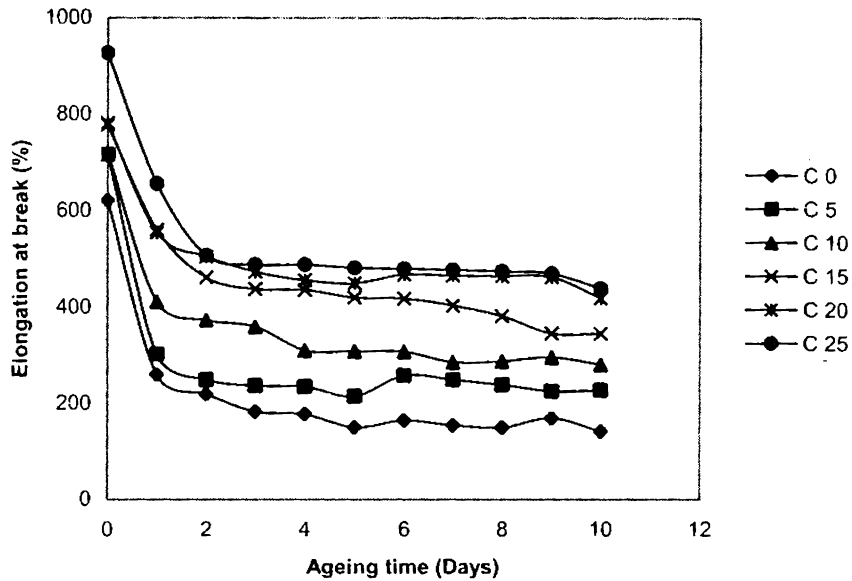

**Fig. 4.33** Variation of tensile strength with ageing time of SBR vulcanizates with different CNSL contents (C 0- 0phr CNSL, C 5- 5 phr CNSL, C 10- 10 phr CNSL, C 15 – 15 phr CNSL, C 20- 20 phr CNSL, C 25- 25 phr CNSL)

Fig. 4.33 shows the variation in tensile strength with progressive ageing. The immediate effect of adding CNSL is to decrease the tensile strength of the unaged material marginally. This can be attributed to the slow reaction between CNSL and rubber. Tensile strength of vulcanizates without any CNSL and those containing lower than 15% CNSL decreased noticeably with ageing time. The presence of CNSL is seen to retard the ageing action at higher percentages of CNSL (like 25%). The antioxidant behavior of CNSL by virtue of the substituted phenol structure may account for this.



## 2. Elongation at break



**Fig. 4.34 Variation of elongation at break with ageing time of SBR vulcanizates with different CNSL contents**

Fig. 4.34 shows the variation in elongation at break with CNSL content. There was a general increase in elongation at break on addition of CNSL for the unaged material. At initial stages of ageing elongation at break falls for all the samples. Elongation at break decreases soon after due to additional crosslinking and stiffening of rubber chains. But it stabilized after about 2 days of ageing. All the ingredients of CNSL have high boiling points. The plasticiser action of CNSL is hence sustained even after prolonged ageing

### 3. Modulus

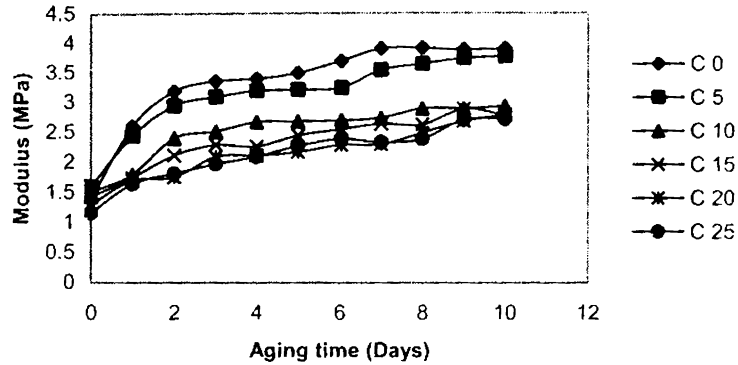

Fig. 4.35 Variation of tensile modulus with ageing time of SBR vulcanizates with different CNSL contents

Fig. 4.35 shows the variation in modulus. Modulus of all the samples increased with ageing time. This could have been due to the stiffening of the vulcanizate as ageing time increased. Some interaction between CNSL and rubber is indicated.

### 4. Tear strength

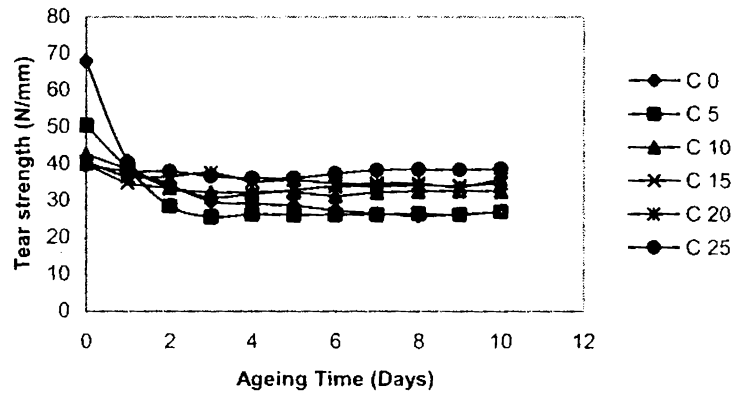
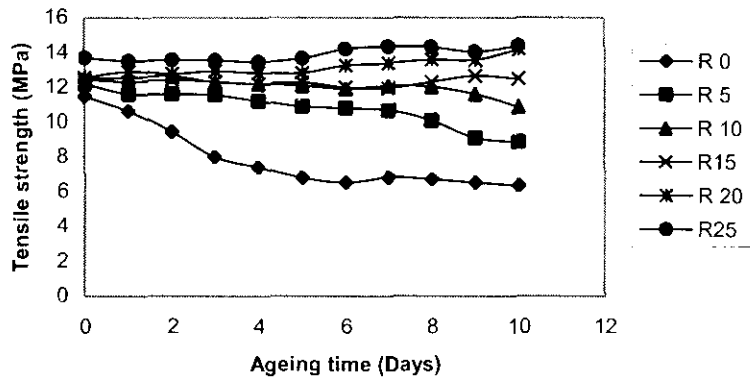

Fig. 4.36 Variation of tear strength with ageing time of SBR vulcanizates with different CNSL contents

Fig. 4.36 shows the variation in tear strength. The immediate effect of adding CNSL is to lower the tear strength of unaged vulcanizates. Tear strength of the vulcanizates without any added CNSL and those containing lower amounts of CNSL (0-15 phr) decreased with ageing time in the beginning. Tear strength values largely remained steady on further ageing for all the samples. The presence of CNSL is seen to retard crack generation and propagation. This is likely to be related to the long chain substitution which can lead to chain entanglement.

## b. Resin content

### 1. Tensile strength



**Fig. 4.37 shows the variation of tensile strength with ageing time of SBR vulcanizates with different resin contents (R 0- 0phr resin, R 5- 5 phr resin, R 10- 10 phr resin, R 15 – 15 phr resin, R 20- 20 phr resin, R 25- 25 phr resin)**

Fig. 4.37 shows the variation in tensile strength with ageing time of vulcanizates containing different percentages of phenol- CNSL- hexa resin. The immediate effect of adding the resin is to increase the tensile strength of the unaged vulcanizates. This can be due to additional crosslinking reactions involving rubber and resin. Tensile strength of vulcanizates without any added resin and those containing lower percentages of resin decreases with ageing time. Tensile strength of vulcanizates with higher amounts of resin content on the other hand increased with ageing time. This indicates additional network chains resulting from crosslinking between resin and rubber. Samples containing resin maintain higher values of tensile strength at all stages of ageing.

## 2. Elongation at break

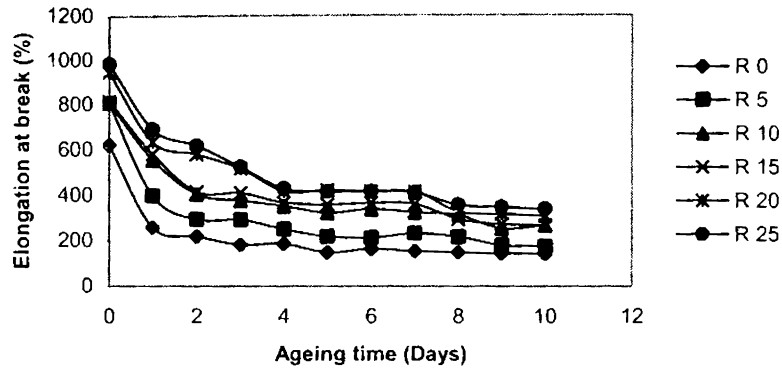

**Fig. 4.38** shows the variation of elongation at break with ageing time of SBR vulcanizates with different resin contents

Fig. 4.38 shows the variation in elongation at break with resin content. Addition of resin increased the elongation at break of unaged vulcanizates indicating some plasticizing action. But it decreased with ageing time at initial stages of ageing. After about 2 days the values get more or less stabilized. Crosslinking of the resin and progressive reaction with the rubber may be responsible for this.

## 3. Modulus

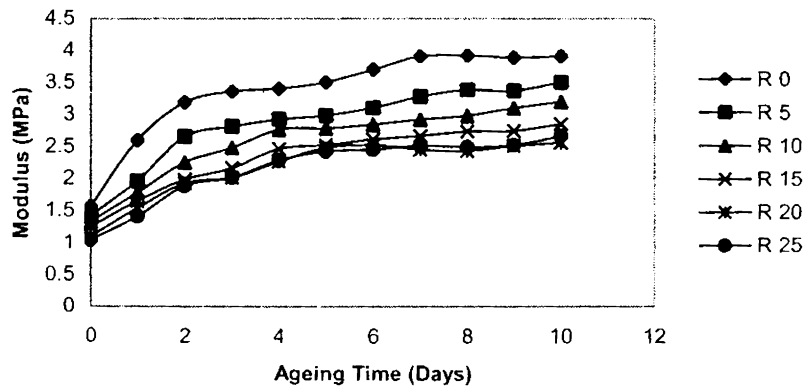

**Fig. 4.39** Variation of modulus with ageing time of SBR vulcanizates with different resin contents

Fig. 4.39 shows the variation in modulus with ageing time of vulcanizates containing different amounts of resin. Modulus of all the samples increased with ageing time. This may be the result of stiffening of chains as ageing proceeds.

**4. Tear strength**

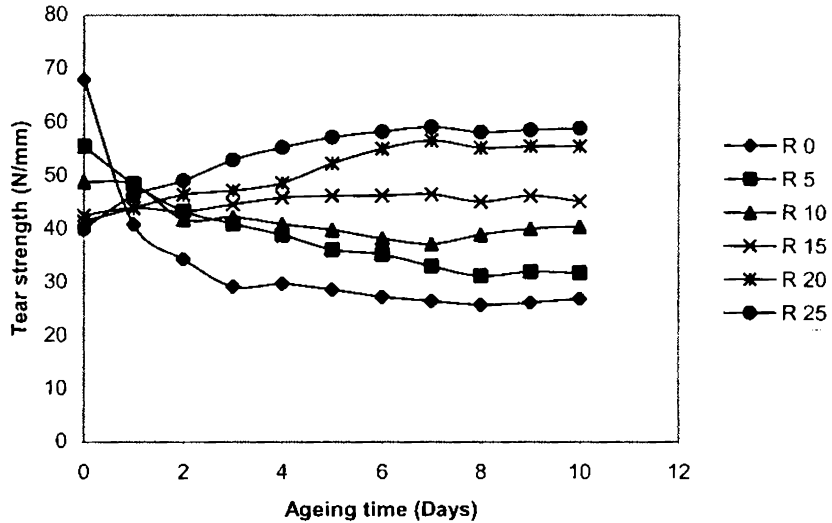

**Fig. 4.40 Variation of tear strength with ageing time of SBR vulcanizates with different resin content**

Fig. 4.40 shows the variation in tear strength with ageing time of vulcanizates containing different amounts of resin. Vulcanizates without any added resin showed a sharp decreasing tendency with ageing time in the beginning. Tear strength of vulcanizates containing higher amounts of resin increased with ageing time. This again points to the progressive reactions in the blend as ageing proceeds.

### 5. Swelling index

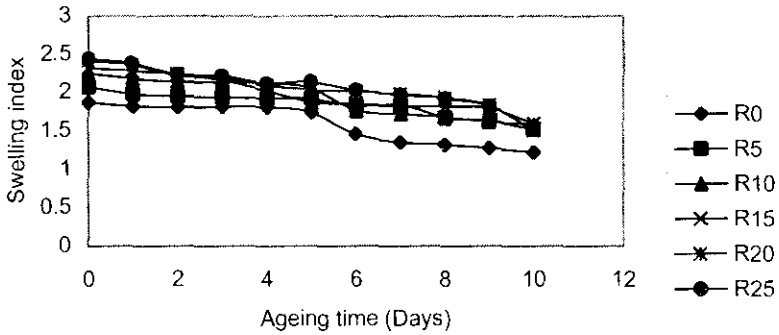

**Fig. 4.41 Variation of swelling index with ageing time of SBR vulcanizates with different resin content**

Fig. 4.41 shows the variation of swelling index. Swelling index decreases as ageing time increases. This indicates increasing levels of cross linking on ageing which is along expected lines.

### 6. Acetone soluble matter

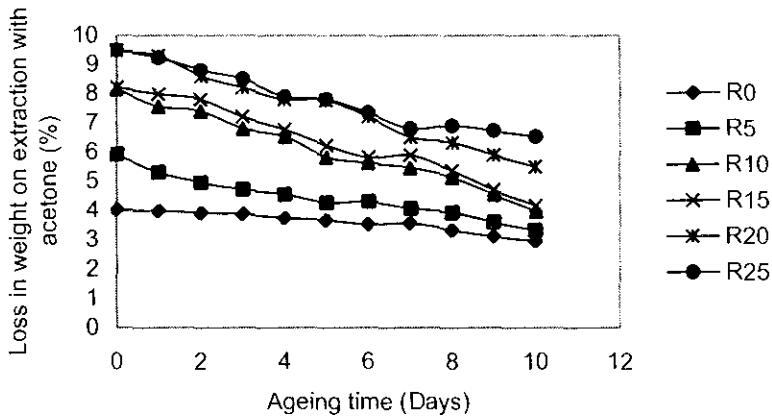

**Fig. 4.42 Variation of loss in weight on extraction with acetone with ageing time of SBR vulcanizates with different resin content**

Fig. 4.42 shows the variation in loss of weight on extraction with acetone. As ageing time increases the matter soluble in acetone decreases. It indicates that

more and more resin gets crosslinked or alternatively, gets incorporated into the network as ageing proceeds. The sample not containing the resin also shows the presence of low molecular weight extractable matter. At low resin percentage, say 5%, the extractable matter after 10 days of ageing is not very different from that of the sample containing no resin. So at this resin content it can be assumed that the resin has fully and inextricably integrated into the rubber.

### c. P: F ratio of resin

In this study a resin with CNSL: P ratio 1:1 and resin content 25 phr was used.

#### 1. Tensile strength

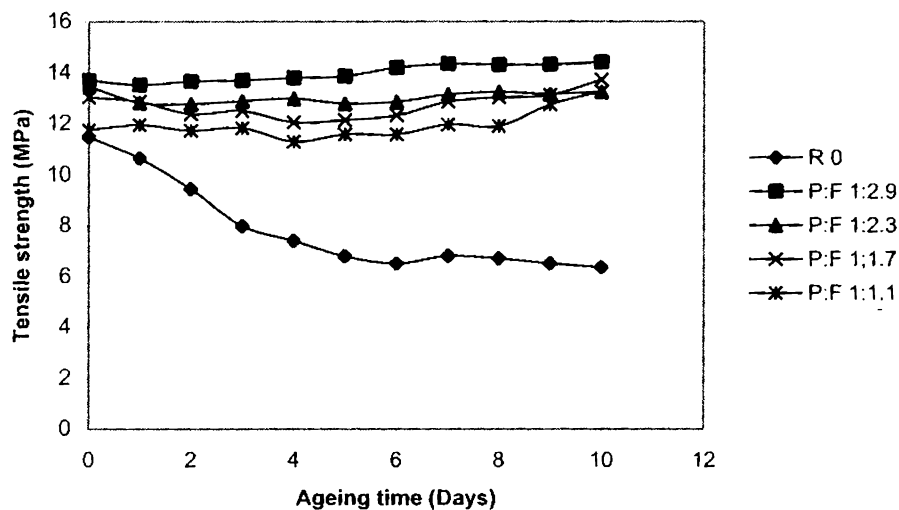
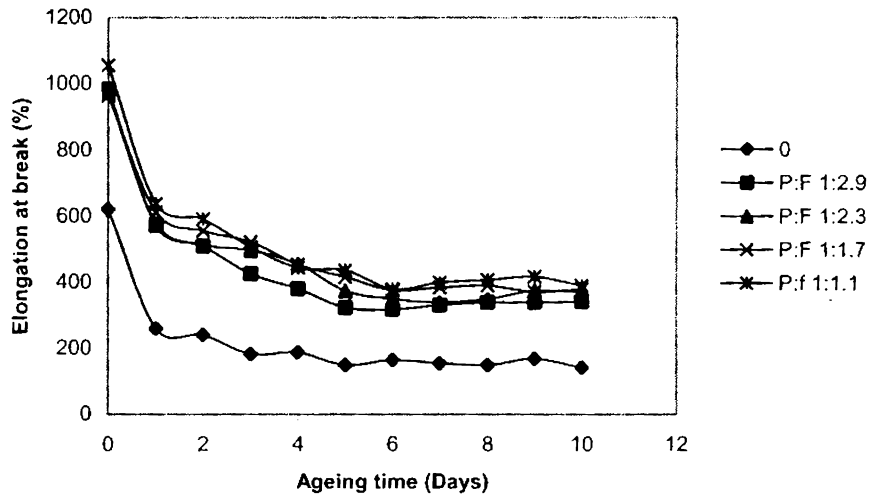

**Fig. 4.43 Variation of tensile strength with ageing time of SBR vulcanizates with resin having different P: F ratios (P: F refers phenol:formaldehyde ratio)**

Fig. 4.43 shows the variation in tensile strength with ageing time of samples with P: F ratios 1: 2.9, 1:2.3, 1:1.7 and 1:1.1. The tensile strength is higher when a resin containing higher amount of formaldehyde is used. Vulcanizates having resin with P: F ratio 1: 2.9 showed almost constant tensile strength. Such a resin completes its reaction with rubber at an early stage of ageing and shows high initial

tensile strength values. Without the resin, there is rapid fall of tensile strength on ageing.

## 2. Elongation at break

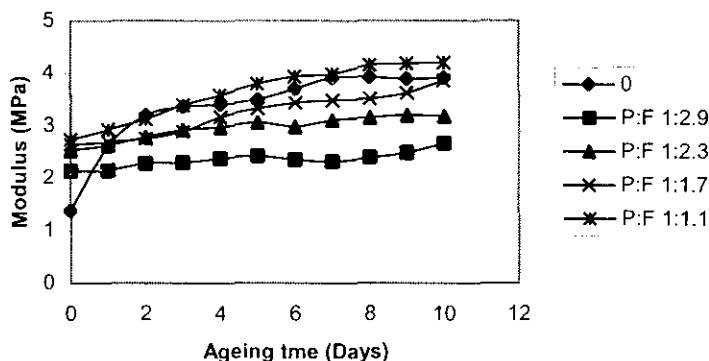

**Fig. 4.44 Variation of elongation at break with ageing time of SBR vulcanizates with resin having different P: F ratios**

Fig. 4.44 shows the variation in elongation at break with ageing time of samples with P: F ratios 1: 2.9, 1:2.3, 1:1.7 and 1:1.1. In all cases there is a reduction in elongation at break on ageing at the early stages. The presence of resin leads to greater elongation and lower formaldehyde content is conducive to higher levels of elongation at break.



### 3. Modulus



**Fig. 4.45** Variation of modulus with ageing time of SBR vulcanizates with resin having different P: F ratios

Fig. 4.45 shows the variation in tensile modulus. As the ageing time increased the modulus increased for all the samples. This could have been due to the stiffening of the network as ageing proceeds. Vulcanizates containing resin with P: F ratio 1:2.9 showed the least variation in modulus on addition of resin. In all cases, there is a rapid fall in modulus at early stages of ageing. The increase in modulus is maximum for a P: F ratio of 1:1.1. At low formaldehyde content (P: F=1:1.1) the condensate will have more benzene rings per molecule. This may affect the chain flexibility and lead to a higher modulus.

### 4. Tear strength

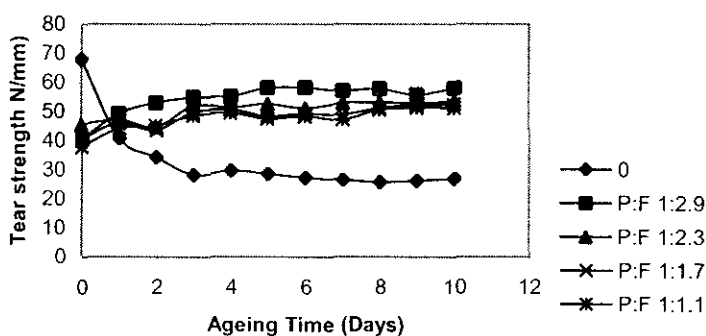

**Fig. 4.46** Variation of tear strength with ageing time of SBR vulcanizates with resin having different P: F ratios

Fig. 4.46 shows the variation in tear strength with ageing time of vulcanizates with different P: F ratios. Tear strength of samples without any resin decreased with ageing time. P: F ratio has very little effect on the contribution of the resin to the tear strength. In the presence of the resin, high values of tear strength are sustained upon ageing.

### 5. Swelling index

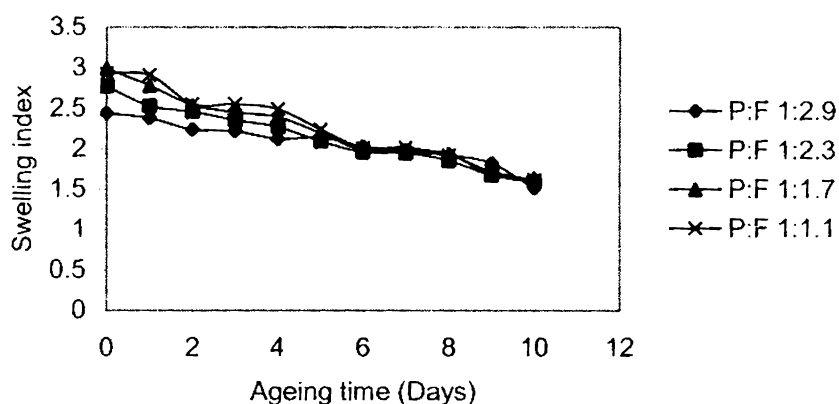

**Fig. 4.47 Variation of swelling index with ageing time of SBR vulcanizates with resin having different P: F ratios**

Fig. 4.47 shows the variation in swelling index. Swelling index decreases as ageing time increases for all samples indicating progressive crosslinking.

## 6. Acetone soluble matter

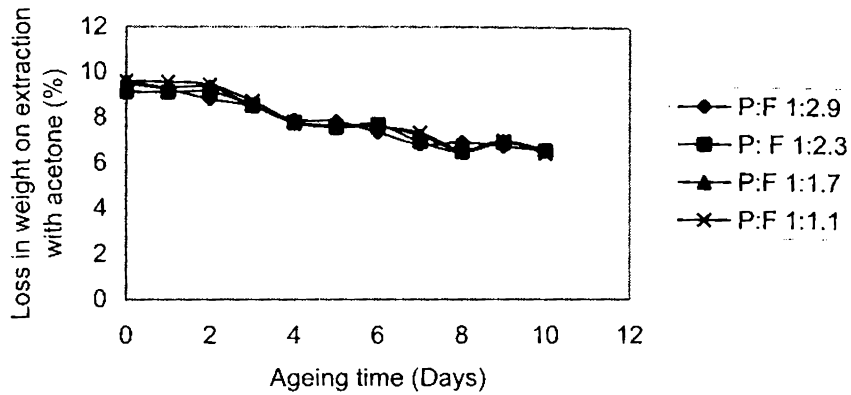

**Fig. 4.48 Variation of acetone soluble matter with ageing time of SBR vulcanizates with resin having different P: F ratios**

Fig. 4.48 shows the variation in acetone soluble matter. Acetone soluble matter decreases as ageing time increases irrespective of the P: F ratio. Again, higher gel contents are indicated as ageing proceeds.

### 4.9.3 Effect of resin content on the ageing properties of miscellaneous rubbers.

In this study resin with P: F ratio 1: 2.9 and CNSL: P ratio 1:1 was used.

#### a. IIR

##### 1. Tensile strength

Figs (4.49-4.52) depict the effect of ageing time on the properties of IIR containing various amounts of the resin.

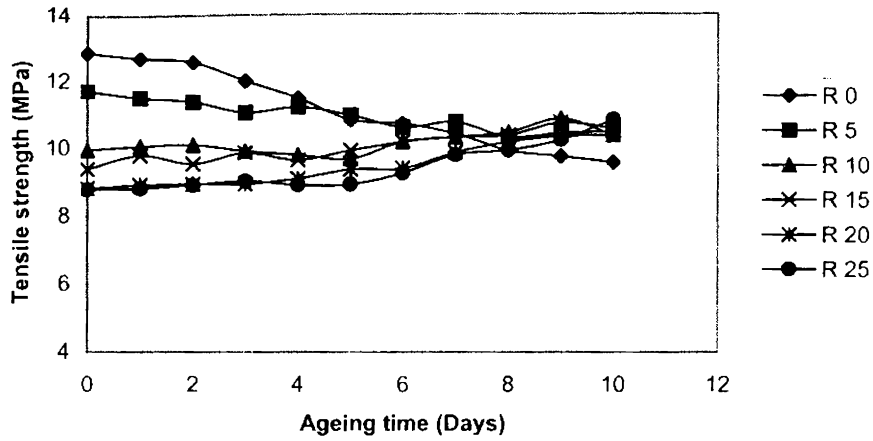

Fig. 4.49 Variation of tensile strength with ageing time of IIR vulcanizates with different resin contents

Referring to Fig. 4.49 before ageing there is a decrease in tensile strength on addition of more and more resin. Tensile strength increases for samples having high resin contents (>15phr).

## 2. Elongation at break

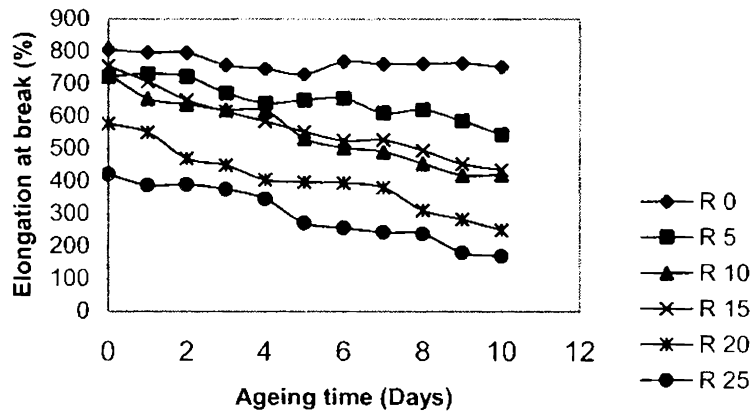
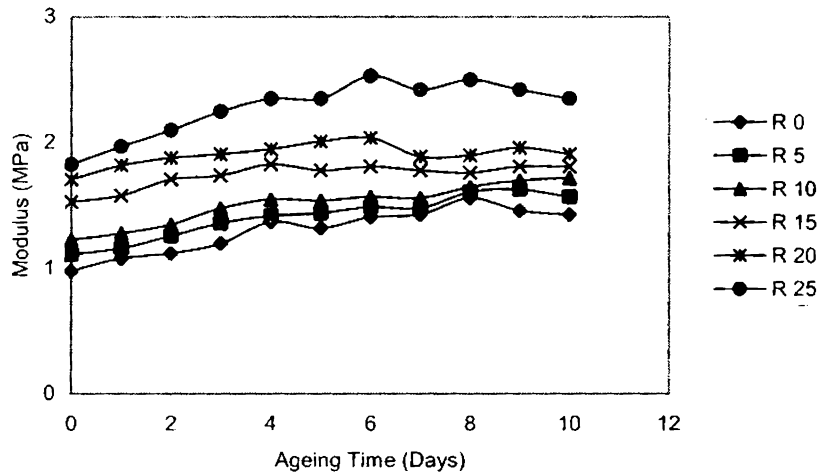

Fig. 4.50 Variation of elongation at break with ageing time of IIR vulcanizates with different resin contents

Fig. 4.50 shows the effect of ageing time on elongation at break. The presence of the resin is seen to lower the elongation at break, the effect steadily increasing on adding more resin. Ageing time has very little effect on the rubber. For higher resin contents there is a steady fall in elongation at break. It is to be concluded that chemical interaction between the resin and rubber increases and intercomponent grafting becomes possible as the resin content increases. This points to some loss of elasticity for samples containing resin as ageing proceeds.

### 3. Modulus



**Fig. 4.51 Variation of modulus with ageing time of IIR vulcanizates with different resin contents**

Fig. 4.51 is a plot of tensile modulus of IIR with ageing time. Maximum tensile modulus is observed for samples containing the maximum resin (25%). There is a slight increase in modulus as ageing proceeds. The magnitude of the modulus almost reaches a constant value at about 7 days and beyond. The slight increase in modulus during ageing suggests the incorporation of the resin into the crosslinked network. The presence of the resin causes stiffening of the chain and leads to a higher modulus.

#### 4. Tear strength

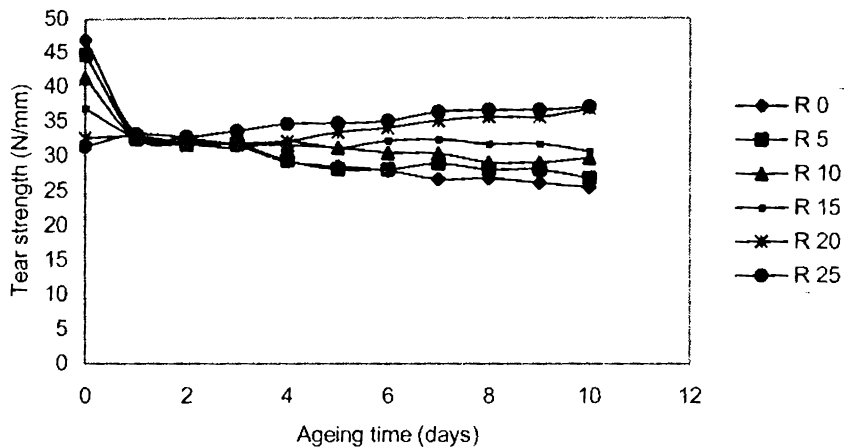

**Fig. 4.52 Variation of tear strength with ageing time of IIR vulcanizates with different resin contents**

Fig. 4.52 shows the effect of ageing time on tear strength of IIR specimens. The effect of the resin is initially to reduce the tear strength but very soon, after one day of ageing, all samples show practically the same tear strength. But beyond that period the tear strength of samples containing the resin shows an increasing trend, the larger the resin content, the higher being the tear strength. Tear strength is one property where the presence of resin subsequently improves the ageing behavior of IIR.

IIR has a limited number of unsaturation sites and shows good ageing characteristics. Even on such a rubber the resin has a very pronounced modifying action.

#### b. CR

##### 1. Tensile strength

Figs 4.53-4.56 show the effect of addition of resin on the properties of CR during ageing.

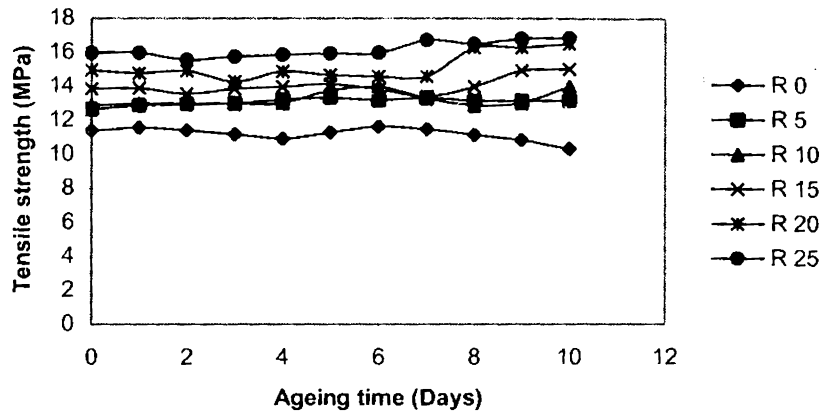

**Fig. 4.53 Variation of tensile strength with ageing time of CR vulcanizates with different resin contents**

Fig. 4.53 shows the variation of tensile strength with ageing time of CR vulcanizates with different resin contents. There is a marginal increase in tensile strength on addition of resin. It is found that ageing does not affect the tensile strength of CR substantially. Even in the absence of resin there is very little reduction in tensile strength after even 10 days of ageing. CR is known to have good thermal resistance.

## 2. Elongation at break

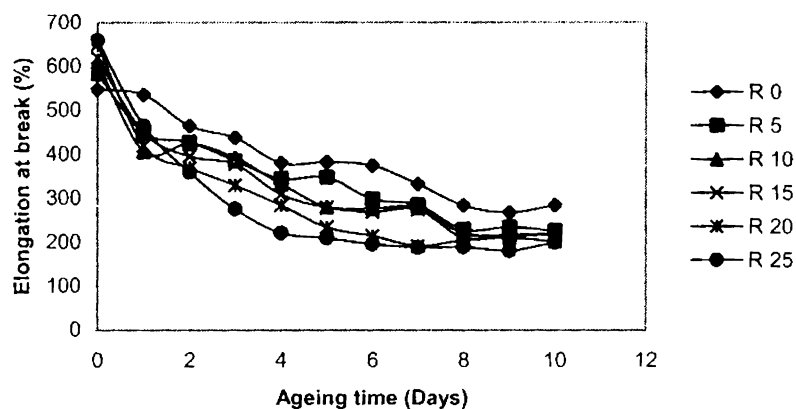
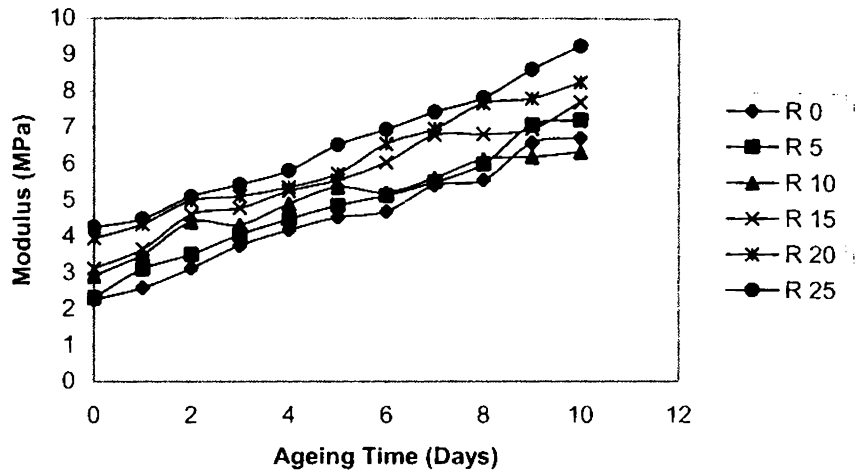

**Fig. 4.54 Variation of elongation at break with ageing time of CR vulcanizates with different resin contents**

Fig. 4.54 shows that elongation at break falls drastically on continuous ageing. The samples containing resin has a comparatively lower elongation at break after ageing. This shows stiffening of the network and possibly incorporation of the resin into the crosslinked network.



### 3. Modulus



**Fig. 4.55 Variation of modulus with ageing time of CR vulcanizates with different resin contents**

Fig. 4.55 shows that there is initially an increase in tensile modulus on addition of resin. All the samples including the one not containing the resin show an increase in modulus as ageing proceeds. Change in modulus on ageing can be the result of chemical changes like dehydrochlorination and interaction between the rubber and resin.

#### 4. Tear strength

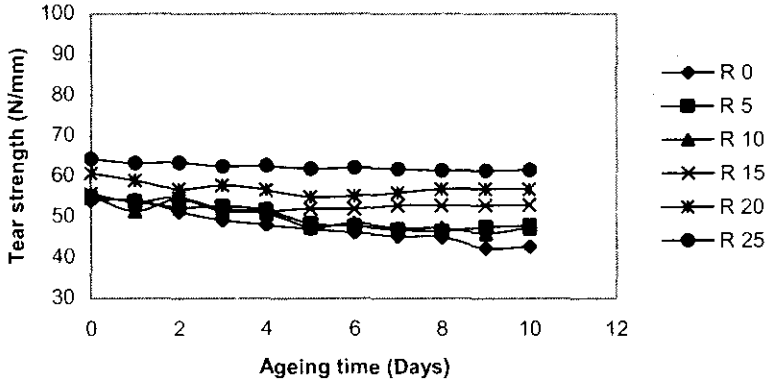

Fig. 4.56 Variation of tear strength with ageing time of CR vulcanizates with different resin contents

Fig. 4.56 is a plot of tear strength with ageing time. CR containing resin has superior tear strength at all stages of the study. Fall in tear strength with ageing time is very moderate.

#### c. EPDM

Figs 4.57-4.59 show the effect of ageing time on the properties of EPDM containing resin.

##### 1. Tensile strength

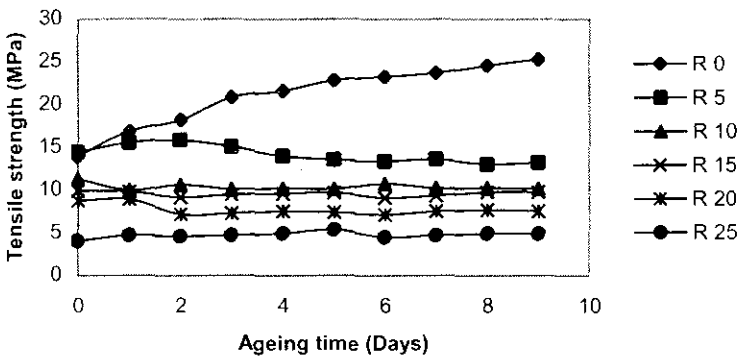
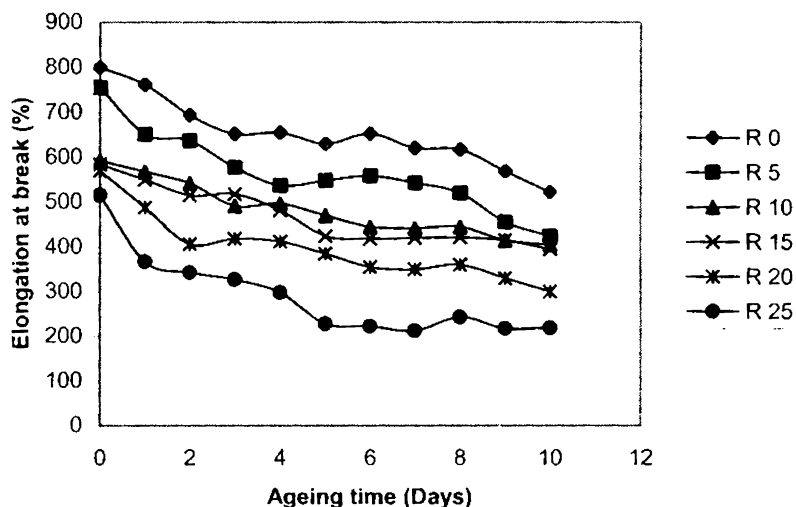

Fig. 4.57 Variation of tensile strength with ageing time of EPDM vulcanizates with different resin contents

Fig. 4.57 shows a reduction in tensile strength on addition of resin. All the samples containing resin show almost constant tensile strength on ageing. EPDM has considerable age resistance. The resin is seen to stabilize the tensile strength.

## 2. Elongation at break



**Fig. 4.58 Variation of elongation at break with ageing time of EPDM vulcanizates with different resin contents**

Fig. 4.58 shows fall in elongation at break on ageing. All samples shows steady reduction in elongation at break on ageing, although elongation at break for samples containing the resin is less at any stage of the ageing process. The resin causes a stiffening of the network without any apparent interaction between the resin and rubber.

### 3. Modulus

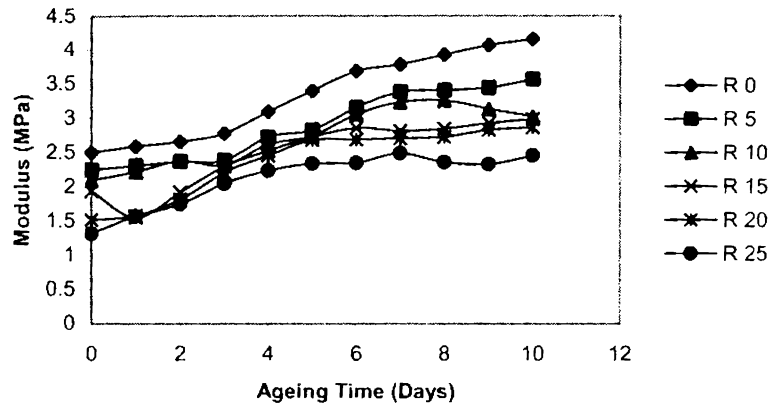

**Fig. 4.59** Variation of modulus with ageing time of EPDM vulcanizates with different resin contents

Fig. 4.59 is a plot of tensile modulus versus ageing time of EPDM. There is a general increase in modulus with ageing time. Samples containing resin have a lower modulus at all stages of the study. Again lack of interaction between resin and rubber is indicated.

### 4. Tear strength

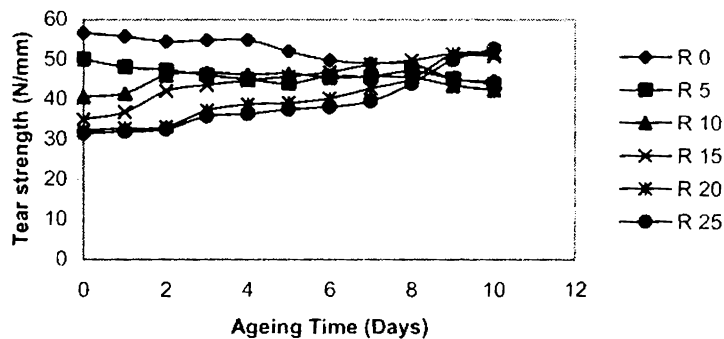
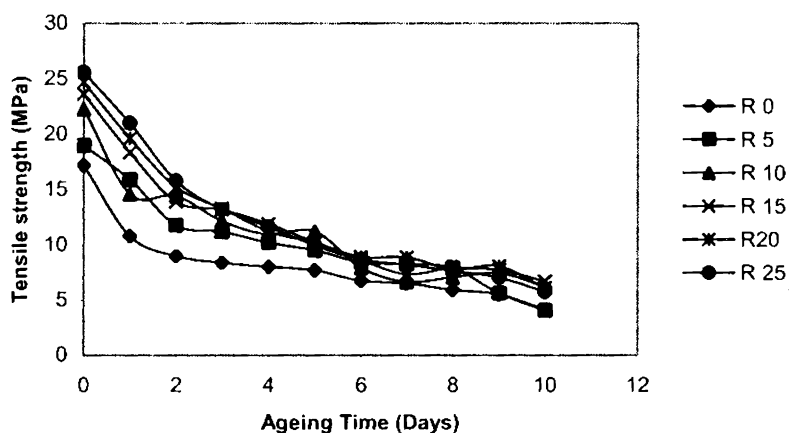

**Fig. 4.60** Variation of tear strength with ageing time of EPDM vulcanizates with different resin contents

Fig. 4.60 shows the change in tear strength with ageing time. Samples containing resin in excess of 10% show an increase in tear strength with ageing time while samples with low resin content show a slight fall in tear strength on ageing. At about 8 days of ageing all samples have practically the same tear strength. The tear strength of samples with higher resin content continues to rise even after that.

#### d. NR

##### 1. Tensile strength



**Fig. 4.61 Variation of tensile strength with ageing time of NR vulcanizates with different resin contents**

Fig. 4.61 shows the variation of tensile strength with ageing time for NR samples. Initially the presence of the resin leads to a high tensile strength. But all the samples show a steep fall in tensile strength on continued ageing. Towards later stages of ageing all the curves come closer. NR is known to undergo chain scission on prolonged periods of ageing. The extent to which this is prevented by the resin is not substantial. Hence this resin cannot be considered as a good ageing modifier for NR.

## 2. Elongation at break

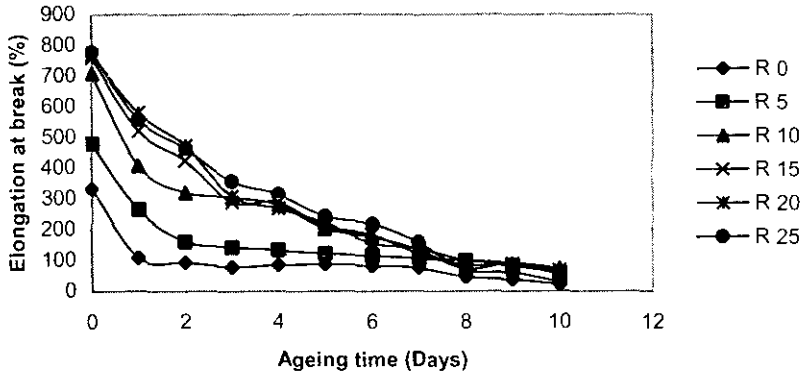

**Fig. 4.62** Variation of elongation at break with ageing time of NR vulcanizates with different resin contents

Fig. 4.62 shows a higher elongation at break for samples containing resin. As in the case of tensile strength there is a steep fall in elongation at break on ageing. The initial high elongation at break of samples containing large amounts of resin falls sharply until at about 8 days of ageing time. The curves almost overlap each other at this stage. The resin is not very effective on prolonged ageing.

## 3. Modulus

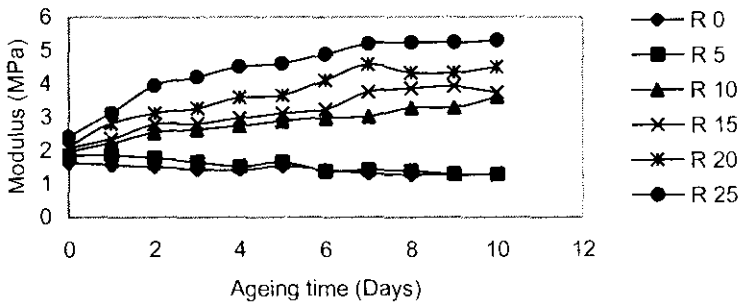

**Fig. 4.63** Variation of modulus with ageing time of NR vulcanizates with different resin contents

Fig. 4.63 shows the variation of modulus on incorporation of resin. Samples containing high amounts of resin show an increase in modulus on ageing while those containing little or no resin show a gradual fall in modulus. This can be attributed to the physical presence of resin in the rubber network.

#### 4. Tear strength

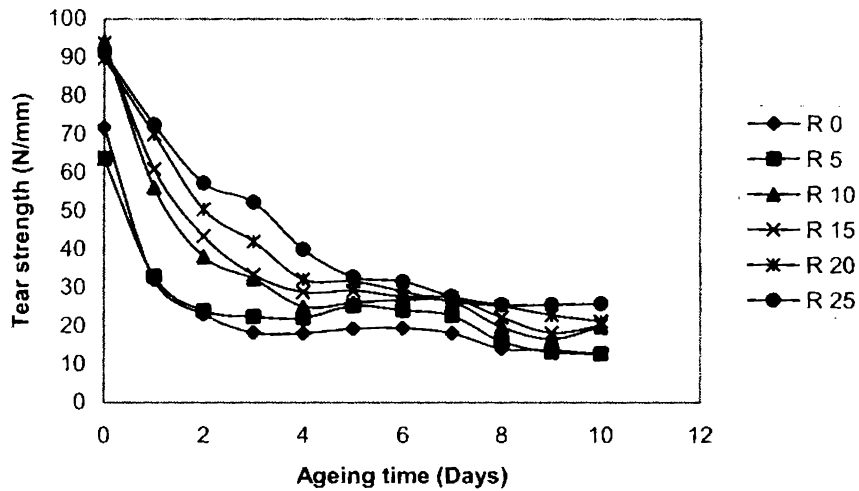

**Fig. 4.64 Variation of tear strength with ageing time of NR vulcanizates with different resin contents**

Fig. 4.64 shows the effect of ageing time on tear strength. Initially high tear strength is observed for samples with high resin content. But towards the later stages of ageing the curves come closer although slightly better retention of tear strength is observed in the case of samples containing high amounts of resin. In general, the resin is not able to prevent fall in most properties on ageing.

#### **4.10 CONCLUSIONS**

The copolymer obtained by condensation of phenol and CNSL with hexamethylenetetramine improves the ageing characteristics of NBR with respect to retention of tensile strength, modulus, tear strength and elongation at break when the resin content is more than 15 phr. Vulcanizates containing resin with a P: F mole ratio 1:2.9 showed the least change in properties on ageing. As the relative amounts of formaldehyde in the resin decreased, the rubber showed increases in tensile strength, tensile modulus and tear strength on ageing. The effect of CNSL was less noticeable than that of phenol. But the addition of CNSL still resulted in substantial improvement in ageing characteristics. Considering the low cost of CNSL and its renewable nature, partial replacement of phenol with CNSL has practical significance.

CNSL improves the ageing characteristics of SBR with respect to tensile strength, modulus, tear strength and elongation at break, when subjected to ageing up to 10 days at 100<sup>0</sup>C. At 15% CNSL, property retention is very high especially in the case of tensile strength, modulus and tear strength. Similarly the resin synthesized from CNSL, phenol and formaldehyde shows very good age modifying properties. In the case of the resin, again, the best results are noticed in the case of tensile strength and tear strength. From the property retention viewpoint about 15% resin is found to be very effective. Vulcanizate containing resin with P: F ratio 1:2.9 showed the least change in properties. The resin is more effective as age resistor than the oil. Tensile strength, modulus and tear strength increases are noticed on ageing.

In the case of IIR the presence of resin leads to reduction in tensile strength, elongation at break and tear strength. IIR shows good ageing properties with resin content above 10 phr.

CR has good inherent resistance to ageing. A marginal increase in tensile strength on addition of resin is retained throughout the ageing period. Tear strength and modulus also show an increase on ageing. The presence of resin does not alter this behavior. The elongation at break reduced on addition of resin and continues to fall on ageing.



Tensile strength, elongation at break, modulus and tear strength of EPDM are found to decrease on addition of resin. Although the samples show good property retention on ageing the use of the resin may not be desirable because of the fall in properties on adding it.

A continuous fall in tensile strength, elongation at break and tear strength in the case of NR is not stopped by the presence of the resin. But initial values of these properties before ageing improve marginally on addition of resin. Only modulus retains/improves the original magnitude on ageing. The presence of resin does not alter this behavior. The use of resin may not be desirable in this case also.

## REFERENCES

1. E.H. Bevilacqua , J. Appl. Polymer Sci., 10,1925 (1966)
2. J.L. Cunnen , Rubber Chem. Technol., 41,182 (1968)
3. J.R. Shelton, Rubber Chem. Technol 56, G71 (1983)
4. P.M. Norling, T.C.P Lee and A.V Tobolsky, Rubber Chem. Technol., 38, 1198 (1965)
5. R.G. Bauman and S.H Maron, J. Polym.Sci., 22, 203 (1956)
6. J.P. Berry and W.F. Watson, J Polym. Sci., 18, 201 (1955)
7. R.W. Keller, Rubber Chem. Technol., 58, 637 (1985)
8. J.L. Morand, Rubber Chem. Technol., 50, 373(1977)
9. J.R. Shelton, Rubber Chem. Technol., 30, 1251 (1957)
10. E.M. Bevilacqua and W.J. Wensch, J.Appl.Polm. Sci., 9, 267 (1965)
11. M.Porter, The Chemistry of Sulfides, A.V. Toboisky ed., Interscience publishers, New York (1968).
12. L. Bateman, The Chemistry and Physics of Rubber-like Substances, Mc Laren and Sons Ltd., London (1963).
13. T.H. Kuran, Rubber World, 192, 20, (1985)
14. A.Y. Corun, Science and Technology of Rubber, F.R Enrich (ed). Academic Press, New York, (1978).
15. L.Slusarski, G.Janowska, J.Therm. Anal. , 30, 1105 (1986).
16. T.O. Skinner and A Awabon , Rubber Age., 99 (11), 76 (1961)
17. R.N. Datte , J.H Wilbrink and F.A Ingham, Indian Rubber J., 8, 52 (1994)
18. J.C. Scarer, Rubber Age, 62,191(1947)
19. R.P. Lattimer, R.A Kinsey and R.W. Layer, Rubber Chem. Technol., 62, 107 (1982)
20. M. Morton, Rubber Technology, Chapman & Hall, (1995).
21. ASTM D 3187-00(2004)
22. ASTM D 3185-99
23. ASTM D 3188-00

#### *Chapter 4*

---

24. ASTM D 3190-00
25. ASTM D 3568-03
26. ASTM D 3184-89
27. ASTM D 573-88
28. ASTM D 412-98 a
29. ASTM D 624-00
30. ASTM D 395-03
31. ASTM D 676-86
32. DIN 53516
33. ASTM D 3616-95
34. ASTM D 297-93
35. S. Van der Meer, *Rec. Trav. Chem.*, 63, 147 (1944)
36. A. Knop, W. Scheib, *Chemistry and Applications of Phenolic Resins*, Springer Verlag, New York (1979)
37. A.R.R. Menon, C.K.S. Pillai and G.B. Nando,, *Journal of Applied Polymer Science*, 68, 1303-1311(1998)
38. A.R.R. Menon, C.K.S. Pillai and G.B. Nando,, *Polymer* 39(17), 4033-4036 (1998)
39. A.R.R. Menon, C.K.S. Pillai and G.B. Nando,, *Journal of Applied Polymer Science*, 51 (13), 2157 (1994)
40. A.R.R. Menon, C.K.S. Pillai and G.B. Nando,, *Kauts.. Gummi Kunsts* 45 (9), 708 (1992)

# Chapter 5

## DEVELOPMENT OF PARTICLEBOARD

---

### 5.1 INTRODUCTION

### 5.2 EXPERIMENTAL

#### 5.2.1 Moulds and other accessories

#### 5.2.2 Moulding procedure

### 5.3 MOULDING OF PARTICLEBOARD

#### 5.3.1 Particleboard from CNSL – hexa reactive mixture (Case 1)

##### a. Ingredients

1. *Binder*
2. *Filler*
3. *Additives*

##### b. Formulation

##### c. Moulding parameters

1. *Cure temperature*
2. *Cure time*
3. *Curing pressure*
4. *Resin content*
5. *P: F ratio*
6. *CNSL: P ratio*

#### 5.3.2 Particleboard from dry moulding powder (Case 2)

##### a. Ingredients

1. *Binder.*
2. *Fillers*
3. *Additives*

##### b. Formulation

##### c. Moulding parameters

1. *Resin content*

*2. P: F ratio*

*3. CNSL: P ratio*

#### **5.4 TESTING OF PARTICLEBOARD**

- a. Density**
- b. Moisture content**
- c. Water absorption**
- d. Tensile strength parallel to surface.**
- e. Tensile strength perpendicular to face (Internal bond strength)**
- f. Static bending tests**
- g. Compressibility**

#### **5.5 RESULTS AND DISCUSSION**

**5.5.1 Effect of moulding conditions and stoichiometry on the properties of particleboard from CNSL-hexa reactive resin (Case 1).**

- a. Effect of cure temperature**
- b. Effect of cure time**
- c. Effect of curing pressure**
- d. Effect of resin content**
- e. Effect of P: F ratio**
- f. Effect of CNSL: P ratio**

**5.5.2 Effect of moulding conditions and stoichiometry on the properties of particleboard from CNSL-phenol-hexa copolymer (Case 2)**

- a. Effect of resin content**
- b. Effect of P: F ratio**
- c. Effect of CNSL: P ratio**

**5.5.3 Effect of fillers**

#### **5.6 CONCLUSIONS**

#### **REFERENCES**

## **DEVELOPMENT OF PARTICLEBOARD**

### **5.1 INTRODUCTION**

Particleboards were first made during the 1930's. The wood particleboard industry evolved due to shortage of timber and the need to dispose of large quantities of sawdust, planar shavings and to a lesser extent, mill residues and other relatively homogeneous waste material produced by other wood industries. They are widely used because they enable wood particles from relatively useless small size and/or low grade timber to be transformed into useful large wooden panels (1).

Properties of the board depend among other things on the kind and amount of binder used. When phenolic resins are used as binders particleboards are characterized by good physical and mechanical properties.

Particleboards are manufactured from particles of wood or other lignocellulose material, formed and pressed together by the use of an organic binder with the help of one or more of agents, such as heat, pressure, catalyst etc (2). The basic material from which particleboards are made are (a) chips, which are wood particles typically used in pulp manufacture (b) flakes, which are mechanically sliced wood particles (c) ribbons, wood particles of specific thickness but varied length (d) shavings, thin, of short length and consisting of ruptured fibers (e) splinters, wood particles greater in length compared to width and (f) sawdust, comparable to particulate fillers but still possessing fibrous structure. Particleboard retains many of the properties of the wood from which it is made.

Particleboards for construction must have high strength and weather resistance. The specific gravity of particleboard may be affected by production parameters like chip form, and reactivity of the resin. Bond strength depends on chip form and binder content.

For special applications, the properties of the boards may be modified by the addition of chemical agents to provide additional properties such as high compressive strength, water resistance, fire resistance and resistance to decay or insect attack.

The largest use of these panels is in the building industry, in which they serve to cover up space – on walls, floors and ceilings. In this application, they may serve various functions- heat insulation, sound insulation etc. They are also widely used in the manufacture of furniture, floor underlayment, cabinets, in home construction and, a significant amount, in the manufacture of automobiles.

Sawdust is recommended as filler for its relatively low specific weight and its abundance as a cheap byproduct in wood workshops. Agricultural wastes such as rice husk, cotton husk, coconut husk etc. can be used for making particleboards that would replace wood products (3-9).

Cost of these boards remains high due to the high cost of the synthetic resin. Natural resin such as that based on CNSL can replace synthetic resins in board manufacture. Application of CNSL as a full or partial replacement for synthetic resin may be of interest in these days of diminishing petroleum resources.

In this study particleboards based on sawdust and CNSL were prepared and the physical and mechanical properties determined for various synthesis and moulding conditions.

## **5.2 EXPERIMENTAL**

This section presents the experimental details of the developmental work on particleboard made from CNSL. Two methods were adopted for the moulding of particleboard.

- a. Board made from CNSL- hexa reactive mixture**
- b. Board made from CNSL- phenol-hexa copolymer resin**

Sections 5.2.1 and 5.2.2 discuss details of mould design and moulding procedure common to both cases. Specific details of each moulding procedure are given in Sections 5.3.1 and 5.3.2.

### **5.2.1 Moulds and other accessories**

The mold is made from mild steel and is a specially designed three piece assembly. The bottom plate and the top plate are separated by a spacer/ frame which holds the mold charge prior to molding. The top plate has a punch that

engages the frame. The punch when pressed by the platen compresses the powder to about one third of its original thickness. The frame has a taper for easy release of the moulded product. Photographs of the mould are given below. The mould is designed for a board of size 300x 300 x 10 mm.

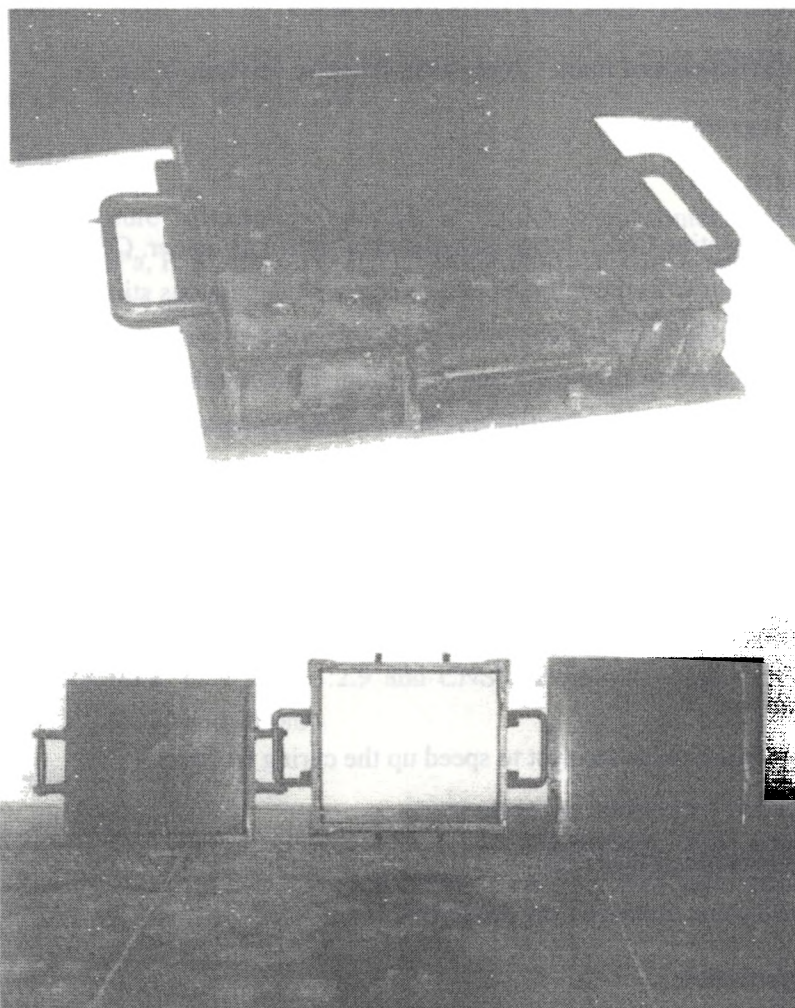

**Fig. 5.1 Three piece mould for particleboard**

### **5.2.2 Moulding procedure**

The mould was heated to moulding temperature prior to molding. The moulding composition was then charged. In order to facilitate easy release of the molding cellophane sheets were kept on both sides of the mould charge. The mould



with the molding composition was placed in a hydraulic press and the required pressure applied. Degassing was done at every five minutes to avoid blisters. After curing, the mould was opened and allowed to cool. The product was then taken out from the mould. A board with dimensions 300x300x10 mm was obtained.

### 5.3 MOULDING OF PARTICLEBOARD

#### 5.3.1 Particleboard from CNSL-hexa reactive mixture (Case 1).

##### a. Ingredients

###### 1. Binder

A reactive CNSL formaldehyde resin served as binder. CNSL and hexa were heated at 100<sup>0</sup>C for 30 minutes in a beaker with continuous stirring. This resin was used for moulding particleboard to study the effect of cure temperature, cure time, curing pressure, resin content and P: F ratio. To study the effect of CNSL: P ratio, resin was prepared by heating mixtures of CNSL, phenol and hexa in different proportions.

###### 2. Filler

Sawdust collected from saw mills. Sawdust contains wood chips of varying sizes from fine dust to pieces as long as 0.5 cm.

###### 3. Additives

1. Magnesium oxide catalyst to speed up the curing reaction.
2. Dimethyl formamide as accelerator.
3. Zinc stearate as lubricant.
4. Naphthalene improve flow properties

##### b. Formulation

|                    |              |
|--------------------|--------------|
| Sawdust            | 100          |
| Resin              | 5-25 %       |
| MgO                | 0.1- 0.5 %   |
| Zinc stearate      | 1 %          |
| Naphthalene        | 0.05- 0.25 % |
| Dimethyl formamide | 0.05- 0.25 % |

**c. Moulding parameters**

Particleboards were made for different values of the following variables

**1. Cure temperature**

Keeping resin content constant at 15%, cure time 15 minutes, curing pressure 13.72 MPa, P: F ratio 1:2.9 and CNSL: P ratio 1:1, cure temperature was varied as 150, 160, 170, 180 and 190<sup>0</sup>C

**2. Cure time**

Keeping cure temperature constant at 150<sup>0</sup>C, resin content 15%, curing pressure 13.72 MPa, P: F ratio 1:2.9 and CNSL: P ratio 1:1, cure time was varied as 5, 10, 15, 20 and 25 minutes.

**3. Curing pressure**

Keeping resin content constant at 15%, cure temperature 150<sup>0</sup>C, cure time 15 minutes, P: F ratio 1:2.9 and CNSL: P ratio 1:1, cure pressure was varied as 3.43, 6.86, 10.78 and 13.72 MPa.

**4. Resin content**

Keeping cure temperature constant at 150<sup>0</sup>C, cure time 15 minutes, curing pressure 13.72 MPa, P: F ratio 1:2.9 and CNSL: P ratio 1:1, resin content was varied as 5, 10, 15, 20 and 25 phr

**5. P: F ratio**

Keeping resin content constant at 15%, cure temperature 150<sup>0</sup>C, cure time 15 minutes, curing pressure 13.72 MPa, and CNSL: P ratio 1:1, P: F ratio was varied as 1:1.1, 1:1.7, 1:2.3 and 1:2.9

**6. CNSL: P ratio**

Keeping resin content constant at 15%, cure temperature 150<sup>0</sup>C, cure time 15 minutes, curing pressure 13.72 MPa and P: F ratio 1:2.9. CNSL: P ratio was varied as 100:0, 75:25, 50:50, 25:75 and 0:100.

Table 5.1 summarizes the moulding parameters maintained for particleboard moulding.

**Table 5.1**  
**Moulding parameters used for particleboard with reactive**  
**CNSL- hexa resin as binder**

| Moulding parameters   |                     |                     |               |            |               |
|-----------------------|---------------------|---------------------|---------------|------------|---------------|
| Cure temperature (°C) | Cure time (minutes) | Curing pressure MPa | Resin content | P: F ratio | CNSL: P ratio |
| 150                   | 15                  | 13.72               | 15            | 1:2.9      | 100:0         |
| 160                   | 15                  | 13.72               | 15            | 1:2.9      | 100:0         |
| 170                   | 15                  | 13.72               | 15            | 1:2.9      | 100:0         |
| 180                   | 15                  | 13.72               | 15            | 1:2.9      | 100:0         |
| 190                   | 15                  | 13.72               | 15            | 1:2.9      | 100:0         |
| 150                   | 5                   | 13.72               | 15            | 1:2.9      | 100:0         |
| 150                   | 10                  | 13.72               | 15            | 1:2.9      | 100:0         |
| 150                   | 15                  | 13.72               | 15            | 1:2.9      | 100:0         |
| 150                   | 20                  | 13.72               | 15            | 1:2.9      | 100:0         |
| 150                   | 25                  | 13.72               | 15            | 1:2.9      | 100:0         |
| 150                   | 15                  | 3.43                | 15            | 1:2.9      | 100:0         |
| 150                   | 15                  | 6.86                | 15            | 1:2.9      | 100:0         |
| 150                   | 15                  | 10.78               | 15            | 1:2.9      | 100:0         |
| 150                   | 15                  | 13.72               | 15            | 1:2.9      | 100:0         |
| 150                   | 15                  | 13.72               | 5             | 1:2.9      | 100:0         |
| 150                   | 15                  | 13.72               | 10            | 1:2.9      | 100:0         |
| 150                   | 15                  | 13.72               | 15            | 1:2.9      | 100:0         |
| 150                   | 15                  | 13.72               | 20            | 1:2.9      | 100:0         |
| 150                   | 15                  | 13.72               | 25            | 1:2.9      | 100:0         |
| 150                   | 15                  | 13.72               | 15            | 1:2.9      | 100:0         |
| 150                   | 15                  | 13.72               | 15            | 1:2.3      | 100:0         |
| 150                   | 15                  | 13.72               | 15            | 1:1.7      | 100:0         |
| 150                   | 15                  | 13.72               | 15            | 1:1.1      | 100:0         |
| 150                   | 15                  | 13.72               | 15            | 1:2.9      | 100:0         |
| 150                   | 15                  | 13.72               | 15            | 1:2.9      | 75:25         |
| 150                   | 15                  | 13.72               | 15            | 1:2.9      | 50:50         |
| 150                   | 15                  | 13.72               | 15            | 1:2.9      | 25:75         |
| 150                   | 15                  | 13.72               | 15            | 1:2.9      | 0:100         |

### **5.3.2 Particleboard from dry moulding powder (Case 2)**

#### **a. Ingredients**

##### **1. Binder.**

A dry moulding powder composition based on phenol-CNSL-hexa copolymer was prepared. Details are given in Section 2.3

##### **2. Fillers**

1. Sawdust – collected from sawmills
2. Rice husk –collected from rice mills.

##### **3. Additives**

1. Magnesium oxide catalyst to speed up the curing reaction.
2. Dimethyl formamide as accelerator.
3. Zinc stearate as lubricant.
4. Naphthalene improve flow properties.

#### **b. Formulation**

|                    |             |
|--------------------|-------------|
| Sawdust            | 100         |
| Resin              | 5-25 %      |
| MgO                | 0.1- 0.5%   |
| Zinc stearate      | 1 %         |
| Naphthalene        | 0.05- 0.25% |
| Dimethyl formamide | 0.05- 0.25% |

#### **c. Moulding parameters**

##### **1. Resin content**

Keeping cure temperature constant at 150<sup>0</sup>C, cure time 15 minutes, curing pressure 13.72 MPa , P: F ratio 1:2.9 and CNSL: P ratio 1:1, resin content was varied as 5, 10, 15, 20 and 25 phr

**2. P: F ratio**

Keeping resin content constant at 15%, cure temperature 150<sup>0</sup>C, cure time 15 minutes, curing pressure 13.72 MPa, and CNSL: P ratio 1:1, P: F ratio was varied 1:1.1, 1:1.7, 1:2.3 and 1:2.9

**3. CNSL: P ratio**

Keeping resin content constant at 15%, cure temperature 150<sup>0</sup>C, cure time 15 minutes, curing pressure 13.72 MPa, P: F ratio 1:2.9 and CNSL: P ratio 1:1, CNSL: P ratio was varied as 100:0, 75:25, 50:50, 25:75 and 0:100.

**Table 5.2**

**Moulding parameters used for moulding particleboard with**

**CNSL- phenol-hexa resin as binder (Moulding temperature =150<sup>0</sup>C, cure time = 15 minutes, Moulding pressure = 13.72 MPa )**

| Resin content | P: F ratio | CNSL: P ratio |
|---------------|------------|---------------|
| 5             | 1:2.9      | 50:50         |
| 10            | 1:2.9      | 50:50         |
| 15            | 1:2.9      | 50:50         |
| 20            | 1:2.9      | 50:50         |
| 25            | 1:2.9      | 50:50         |
| 15            | 1:2.9      | 50:50         |
| 15            | 1:2.3      | 50:50         |
| 15            | 1:1.7      | 50:50         |
| 15            | 1:1.1      | 50:50         |
| 15            | 1:2.9      | 100:0         |
| 15            | 1:2.9      | 75:25         |
| 15            | 1:2.9      | 50:50         |
| 15            | 1:2.9      | 25:75         |
| 15            | 1:2.9      | 0:100         |

## **5.4 TESTING OF PARTICLEBOARD**

**(AS PER IS 2380-1977 (10))**

### **a. Density**

The specimen used was of 7.5 cm wide and 15 cm long.

Density = mass of the specimen in gm / {length (cm) x width (cm) x thickness (cm)} g/cm<sup>3</sup>

### **b. Moisture content**

The specimen used was of 7.5 cm wide and 15 cm long. It was then dried in an oven at 103°C until the mass was constant. The moisture content, expressed as percentage of oven dry mass, was calculated

Moisture content =  $(M_1 - M_0) / M_0 \times 100$

$M_1$  – initial mass

$M_0$  – oven dry mass

### **c. Water absorption**

Test specimen used was 30 X 30 cm size. After conditioning the specimen was weighed and the width, length and thickness measured. The specimen was then submerged horizontally in clean water maintained at a temperature of 27°C. The test specimens were separated by at least 15mm from each other and from the bottom and sides of the container. After a 24 hours submersion, the specimen was suspended to drain for 10 minutes, at the end of which the excess water was removed and the specimen was immediately weighed. The amount of water absorbed was calculated from the increase in mass of the specimen and the water absorption was expressed as percentage by mass after conditioning.

### **d. Tensile strength parallel to the surface**

Tensile strength in the parallel- to- face orientation is the resistance of a board material when pulled apart parallel to its surface. Tensile strength parallel to the surface is the load at the time of fracture divided by the cross sectional area (width x thickness) of the specimen.

l - length of specimen, mm

#### f. Static bending tests

Static bending tests determine both modulus of rupture (MOR) and modulus of elasticity (MOE) of composites. Universal Testing Machine was used for measuring these properties. Samples of 300 mm length, 10mm thickness and 50 mm width were used. The test was conducted at a crosshead speed of 6 mm/min and loading span used was 240 mm.

##### 1. Modulus of rupture (MOR)

Modulus of rupture is the ultimate bending stress of a material in flexure or bending and it is frequently used in comparing one material to another.

$$\text{MOR} = 3PL/2bd^2.$$

MOR - Modulus of rupture, MPa.

P - maximum bending load, N.

L - length of span, mm, 24x thickness.

b - width of specimen, mm.

d - thickness of specimen, mm.

##### 2. Modulus of elasticity (MOE)

Modulus of elasticity is determined from the slope of the straight line portion of the load-deflection curve ( $P_1/Y_1$ ).

$$\text{MOE} = P_1L^3/4bd^3Y_1$$

MOE - stiffness (apparent modulus of elasticity), MPa

P1 - load at proportion limit, N

L - length of span, mm, 24x thickness.

b - width of specimen, mm

d - thickness of specimen, mm

Y1 - centre deflection at proportional limit, mm

A typical load-deflection curve (particleboard moulded with sawdust and CNSL- phenol – hexa copolymer resin with P: F ratio 1:2.9, CNSL: P ratio 1:1 and resin content 25 %) is shown in Fig.5.3

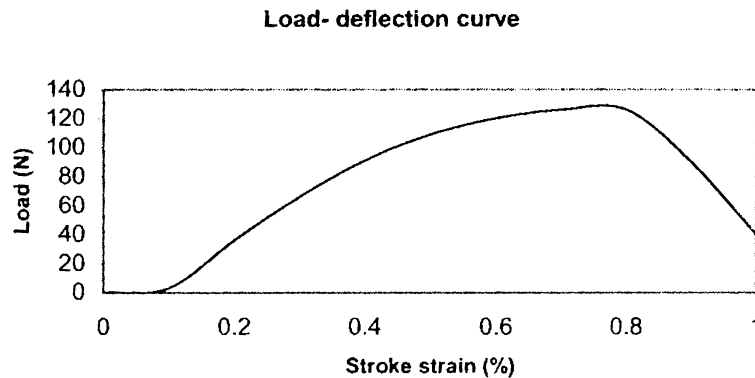

**Fig. 5.4 Load deflection curve for particleboard**

#### **g. Compressibility**

The test specimen used was 50 X 50 X 50 mm. The specimen was prepared by gluing five pieces of the board face to face. The size of the specimen was measured correct to 0.1 mm and mass correct to 0.01g. The test was carried out at room temperature. The specimen was placed horizontally on the platform of the machine in flat position. The load was applied vertically on the specimen, at a constant rate of loading of 0.6 mm/minute.

Initially a load of 10 Kg was given on the specimen and taken as zero position. Then a load of 500 Kg was applied and this load was maintained for 10 minutes. The deformation was measured after 10 minutes and was recorded as the value of compressibility.

### **5.5 RESULTS AND DISCUSSION**

Wood particles consist of cellulose, hemi cellulose, lignin and substances like resins, oils etc. Lignin is highly polymeric substance with a phenolic structure (11). Most abundant chemical sites in the wood cell wall polymers are hydroxyl groups (12)

The sawdust used is predominantly of rosewood. Components of rosewood are geraniol, linalool, nerol, lineole, terpinol, dipentene (13) in addition to cellulose, lignin etc.

Sawdust contain several reactive compounds and functional groups, so that apart from hydrogen bond formation, a number of chemical reactions with phenol-



formaldehyde condensate products can occur (2). The following types of reactions are believed to occur (14). 1) hydrogen bonds form between hydroxyl groups of cellulose and phenolic resin, 2) crosslinking can take place between wood cell wall hydroxyls and formaldehyde and 3) crosslinks take place between the hydroxyl groups on the same or different cellulose, hemi cellulose and lignin polymers. To what extent these three interactions take place is a matter of conjecture.

This section presents the results of various studies relating to the development of particleboards. These results can be divided into two broad categories.

- a. *Particleboard from CNSL- hexa reactive mixture (Case 1) and*
- b. *Particleboards from dry moulding powder consisting of CNSl-phenol- hexa copolymer (Case 2)*

#### **5.5.1. Effect of moulding conditions and stoichiometry on the properties of particleboard from CNSL-hexa reactive resin (Case 1)**

##### **a. Effect of cure temperature**

To study the effect of cure temperature on the properties of particleboard, boards were made with resin content 15 phr, curing pressure 13.42 MPa, cure time 15 minutes, P: F ratio 1:2.9 and CNSL: P ratio 100: 0 and varying cure temperatures.

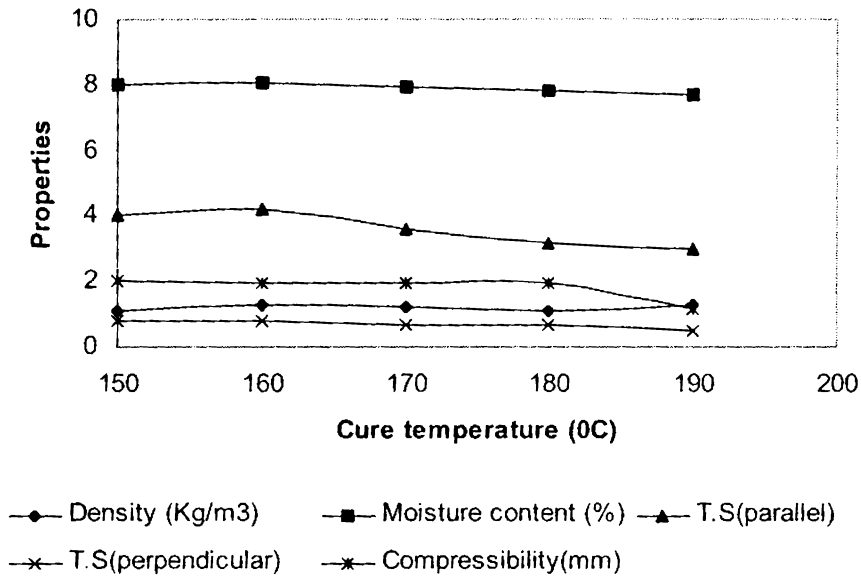

**Fig. 5.5 Variation of properties of the particleboard (Case 1) as a function of cure temperature**

Fig. 5.5 shows the variation in density, moisture content, tensile strength (parallel), tensile strength (perpendicular) and compressibility with cure temperature.

Density is almost constant when the cure temperature changes from 150 to 190°C.

The effect of cure temperature on the moisture content of the resin is not substantial.

Tensile strength (parallel-to- face orientation) is the resistance of a board material when pulled apart parallel to its surface. It is the maximum load a specimen can withstand when subjected to tensile loads in the direction of the length. The board shows maximum tensile strength at 160°C. Tensile strength (parallel) is seen to slightly decrease at high cure temperature. This may be due to

degradation of wood fibers and also the negative effect on the properties of the resin binder.

Tensile strength perpendicular to face is a measure of the resistance of a material when pulled apart in the direction perpendicular to its surface. This test is a true measure of the adhesive / bonding strength of the resin. The stress is applied on a comparatively large area resulting in failure along a section parallel to both faces. Particleboard shows maximum tensile strength (perpendicular) at 150°C. Above this temperature bonding strength decreases. This can be due to possible degradation of fiber or resin. At high temperatures water is eliminated between cellulose hydroxyl groups to form ether bonds (11). Ether bonds are not as amenable as hydroxyl groups to hydrogen bonding with polar phenolic resin. At higher temperatures exudation of extractives to the surface as well as closure of micro pores in cell walls occurs, which reduces the number of active sites for bonding.

Compressibility is almost constant when the cure temperature changes from 150 to 180°C. From 180 to 190°C there is a sudden decrease in compressibility. It is likely that above 180°C the resin becomes too rigid and the board reaches a state of maximum compaction. Hence compressibility falls at this stage.

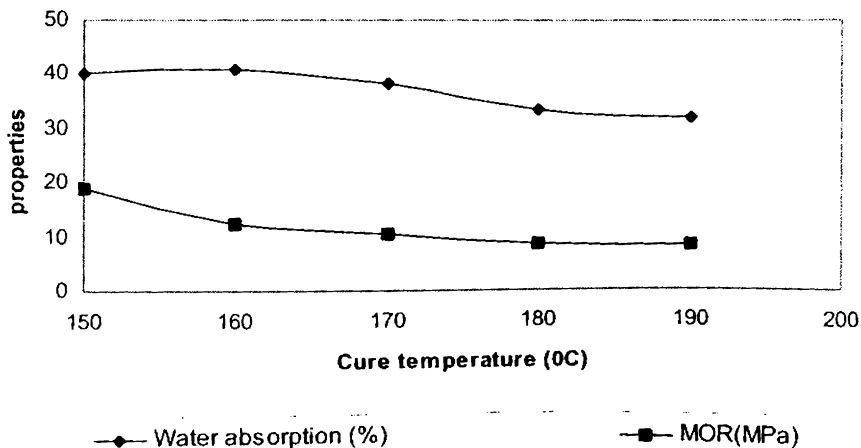
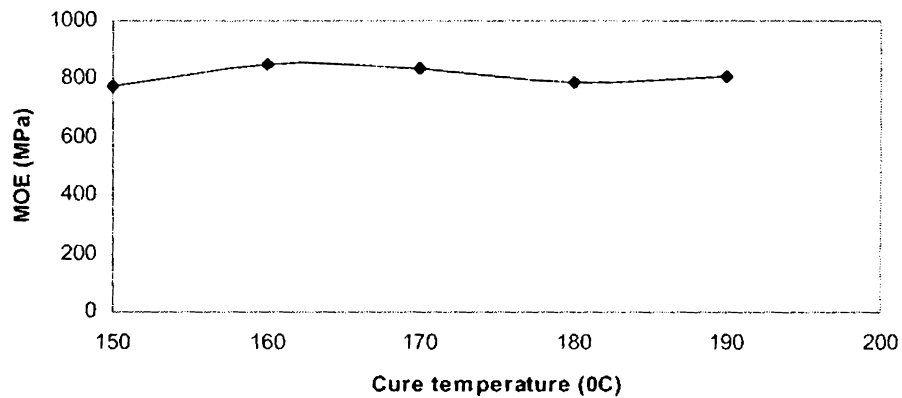

**Fig. 5.6 Variation of properties of the particleboard (Case 1) as a function of cure temperature**

Fig. 5.6 shows the variation in water absorption and MOR with cure temperature.

At high curing temperatures water absorption decreases. At higher temperatures, a more crosslinked and impenetrable board results.

MOR is a measurement of composite board bending strength. MOR is the ultimate bending stress of the material in bending and it is frequently used in comparing one material to another. Maximum MOR is obtained at 150°C which matches the performance required by the Indian Standards. Further increase in cure temperature decreases MOR.



**Fig. 5.7 Variation of MOE of the particleboard (Case 1) as a function of cure temperature**

Fig. 5.7 shows the variation in MOE with cure temperature. MOE is practically unaffected by cure temperature.

**b. Effect of cure time**

To study the effect of cure time on the properties of particleboard, particleboards were made with resin content 15 phr, curing pressure 13.72 MPa,

cure temperature 150°C, P: F ratio 1:2.9 and CNSL: P ratio 100: 0 and varying cure times.

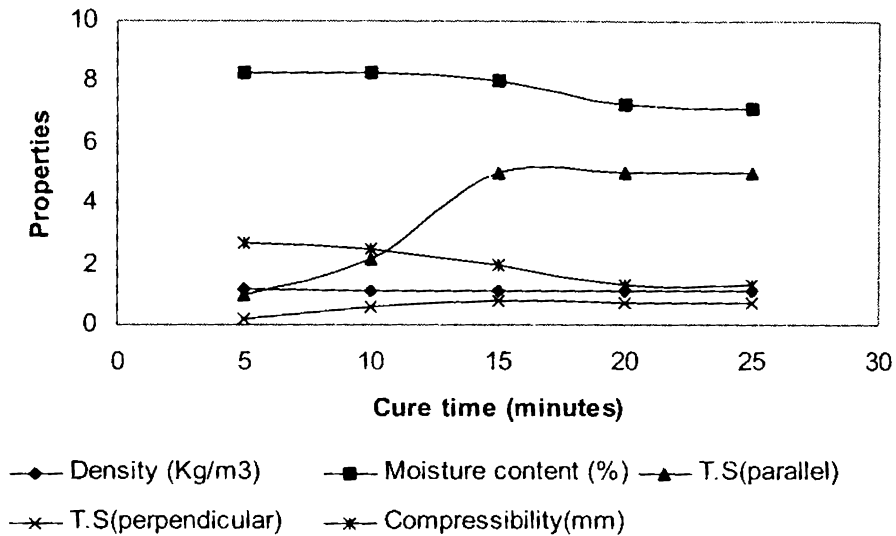

**Fig. 5.8 Variation of properties of the particleboard (Case 1) as a function of cure time**

Fig. 5.8 shows the variation in density, moisture content, tensile strength (parallel), tensile strength (perpendicular) and compressibility with cure time.

Density is almost constant when the cure time varies between 5 and 25 minutes.

Moisture adds to the weight and can also affect the environmental durability of particleboards. Moisture content is almost constant when the cure time increases from 5 to 15 minutes. But there is a slight fall from 15 to 25 minutes. But such long cure times can lead to degradation of properties.

When the cure time increases tensile strength (parallel) increases up to about 15 minutes. Tensile strength is almost constant with further increase in cure time. Optimum cure time is about 15 minutes from the viewpoint of tensile strength (parallel).

Tensile strength (perpendicular) is found to be maximum when the cure time is 15 minutes. Above this time degradation of resin or sawdust can occur which decreases the bonding strength. When the cure time is about 15 minutes the board shows acceptable values. 15 minutes are seen to be the optimum cure time.

Compressibility decreases when the cure time increases from 5 to 15 minutes. Thereafter there is little change in compressibility. At this point the particles were in their most compact form. Therefore no further decrease in volume could take place.

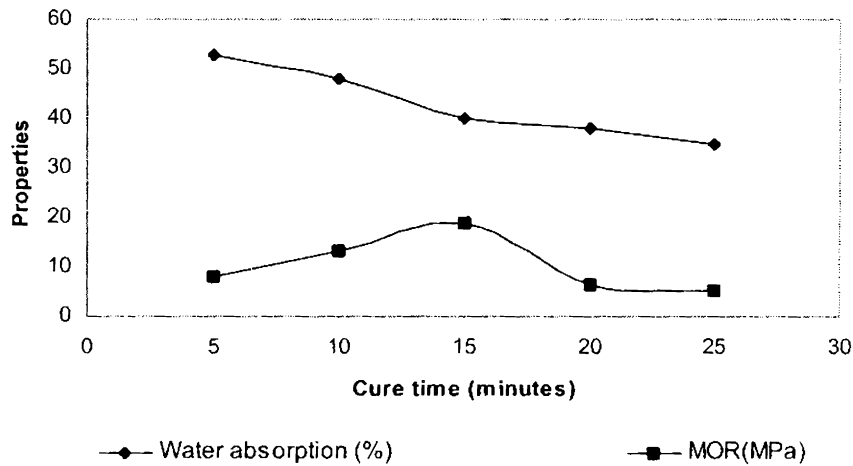

**Fig. 5.9 Variation of properties of the particleboard (Case 1) as a function of cure time.**

Water absorption decreases when the cure time increases from 5 to 25 minutes.

There is an increase in MOR when the cure time increases from 5 to 15 minutes. Further increase in cure time results in reduction of MOR. A cure time 10 minutes is sufficient to get a board with a standard value of MOR.

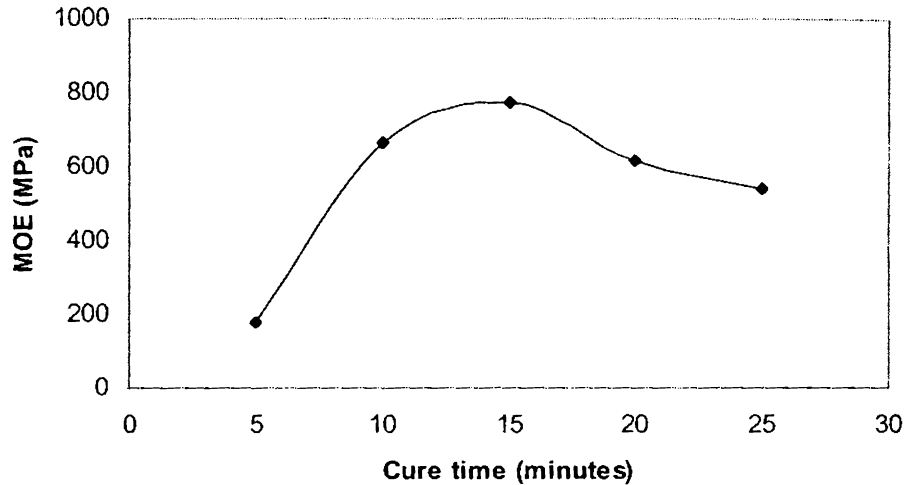

**Fig. 5.10 Variation of MOE of the particleboard (Case 1) as a function of cure time**

Fig. 5.10 shows the variation in MOE with cure time. MOE is maximum at around 15 minutes.

**c. Effect of curing pressure**

Particleboards were moulded with cure temperature 150<sup>0</sup>C, cure time 15 minutes, resin content 15 phr. P: F ratio 1:2.9, CNSL: P ratio 100:0 and varying curing pressures viz. 3.43, 6.86, 10.78 and 13.72 MPa. The boards made at 3.43, 6.86 and 10.78 showed very low bonding strength and the results are not reproduced here. Hence a maximum pressure of 13.72 MPa is needed.

#### d. Effect of resin content

To study the effect of resin content on the properties of particleboard, particleboards were moulded with curing pressure 13.72 MPa, cure time 15 minutes, cure temperature 150°C, P: F ratio 1:2.9 and CNSL: P ratio 100: 0 and varying resin contents

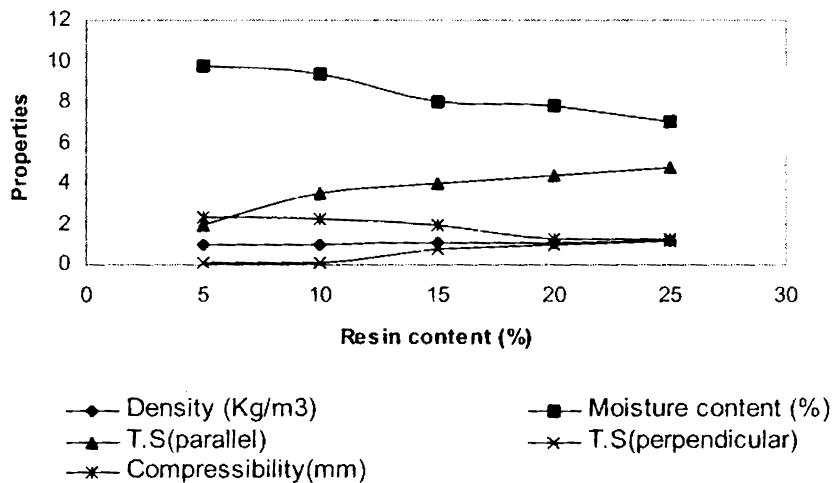

**Fig. 5.11 Variation of properties of the particleboard (Case 1) as a function of resin content**

Fig. 5.11 shows the variation in density, moisture content, tensile strength (parallel), tensile strength (perpendicular) and compressibility with cure time.

A higher resin content increases the average density of the board. A higher density leads to a higher strength. But it is undesirable in particleboards because panels become inconveniently heavy. Although many other properties improve with density practical difficulties arise because of the inability of nails to pierce dense particleboards. On the other hand a low density is meaningful only if mechanical and other properties are satisfactory. There is a small increase in density as the resin content increases from 5 to 25%. The resin content has to be



decided based on changes in properties which are more critical and more sensitive to resin content.

There is a gradual decrease in moisture content as the resin content increases from 5 to 25%. The fall in moisture content with increase resin content can be attributed to many reasons. The higher exothermic temperature reached at higher resin content can lead to a more effective expulsion of moisture. Further, a more effective encapsulation/ bonding of the fibers at higher resin content can prevent subsequent moisture absorption by the particleboard.

There is a gradual increase in tensile strength (parallel) as the resin content increases. A stronger bonding of the fibers can be expected at higher resin contents.

There is a sudden increase in tensile strength (perpendicular) as the resin content increases from 5 to 15%. When the resin content is more than 15 % the board shows tensile strength values as specified by the standards. Below 15% the resin content is not sufficient to give cohesion between the fibers.

There is hardly any dependence of compressibility on resin content.

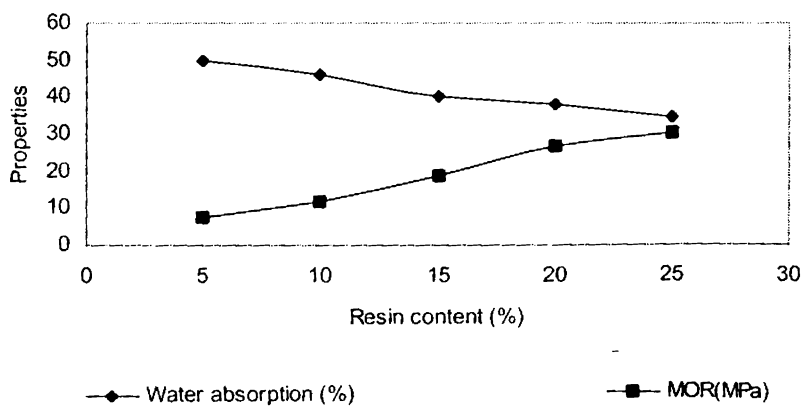
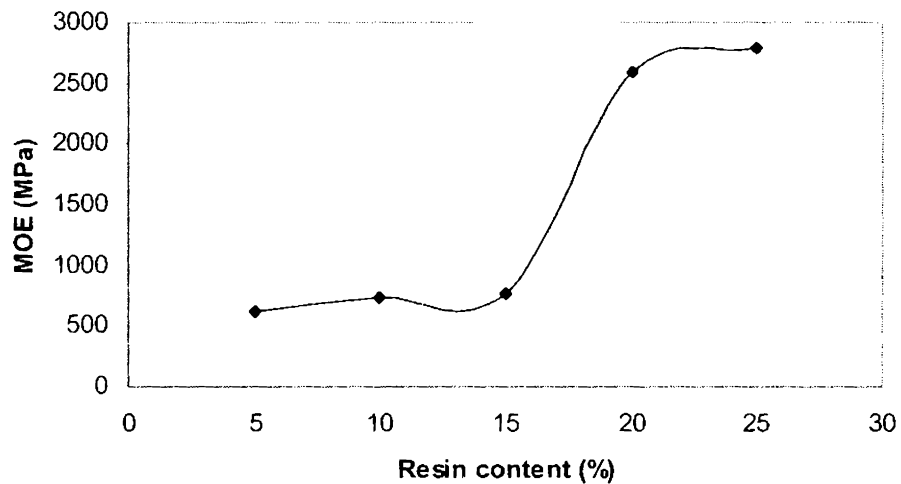

**Fig. 5.12 Variation of properties of the particleboard (Case 1) as a function of resin content**

Fig. 5.12 shows the variation of water absorption and MOR with resin content..

Water absorption decreases gradually as the resin content increases from 5 to 25%. Encapsulation/ binding of the fiber by the resin and closing of the capillaries within the board as the resin content increases can be the reason for this.

MOR increases gradually as the resin content increases from 5 to 25%. When the resin content is about 10% the board shows commercially acceptable values.



**Fig. 5.13 Variation of MOE of the particleboard (Case 1) as a function of resin content**

Fig. 5.13 shows the variation of MOE of the particleboard as a function of resin content. There is a sudden increase in MOE as the resin content increases from 15 to 20%. Above 20% MOE is almost constant. Around 20% resin content is necessary to meet the commercial specifications as far as MOE is concerned.

e. Effect of P: F ratio

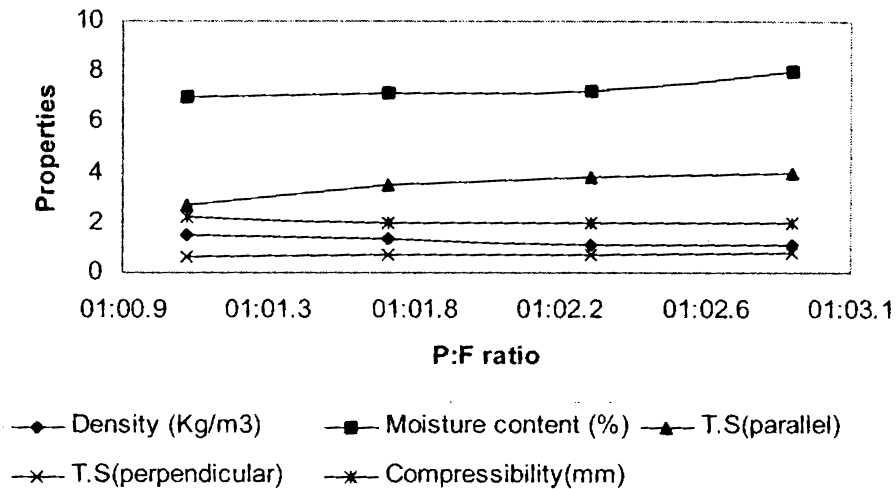

**Fig. 5.14 Variation of properties of the particleboard (Case 1) as a function of P: F ratio**

Fig. 5.14 shows the variation in density, moisture content, tensile strength (parallel), tensile strength (perpendicular) and compressibility with P:F ratio.

Density is almost constant when the formaldehyde content changes from 1:1.1 to 1: 2.9.

Moisture content is almost constant when the formaldehyde content increases from 1:1.1 to 1: 2.9. The slight increase indicated may be due to greater presence of CH<sub>2</sub>OH groups as the formaldehyde proportion increases.

Tensile strength (parallel) increases as formaldehyde content increases. Bonding between the fibers is good when a resin containing higher amounts of

formaldehyde is used. At high formaldehyde content the degree of crosslinking is high.

Particleboard prepared from resin containing higher amounts of formaldehyde showed slightly improved bonding strength. Resin with high formaldehyde content may be more reactive towards fibers apart from being more crosslinkable.

Compressibility decreases as formaldehyde content increases. A higher degree of crosslinking and binding between sawdust and resin may be responsible for this.

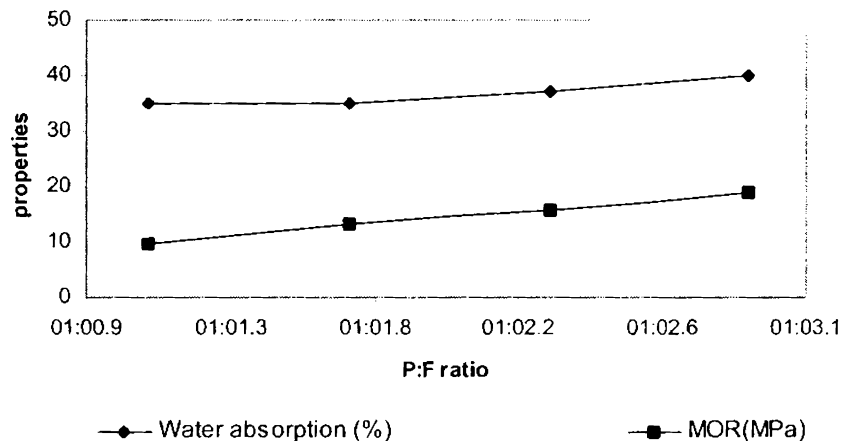

**Fig. 5.15 Variation of properties of the particleboard (Case 1) as a function of P: F ratio**

There is not much variation in water absorption as the formaldehyde content changes.

MOR increases gradually as the formaldehyde content increases. Resins with P: F ratio 1: 1.7 and less shows values higher than that required by the standard.

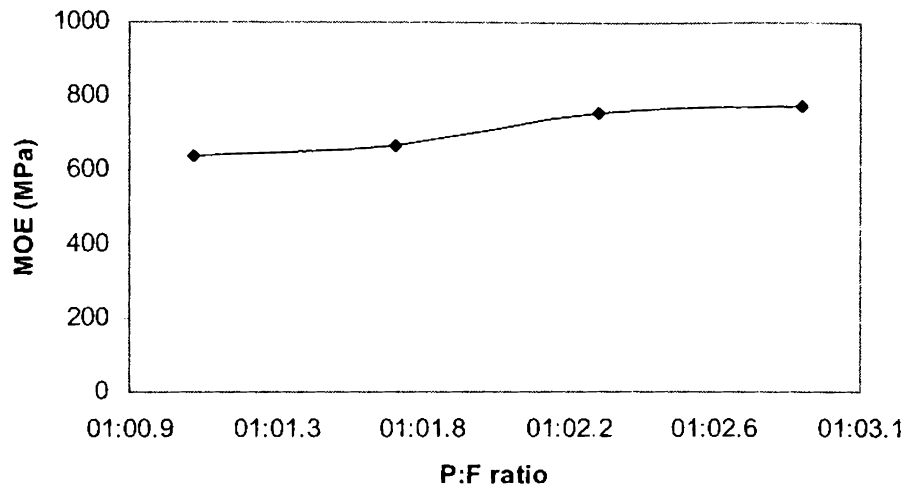

**Fig. 5.16 Variation of MOE of the particleboard (Case 1) as a function of P: F ratio**

Fig. 5.16 shows the variation in MOE with P: F ratio. MOE increases only slightly as formaldehyde content increases.

## f. Effect of CNSL: P ratio

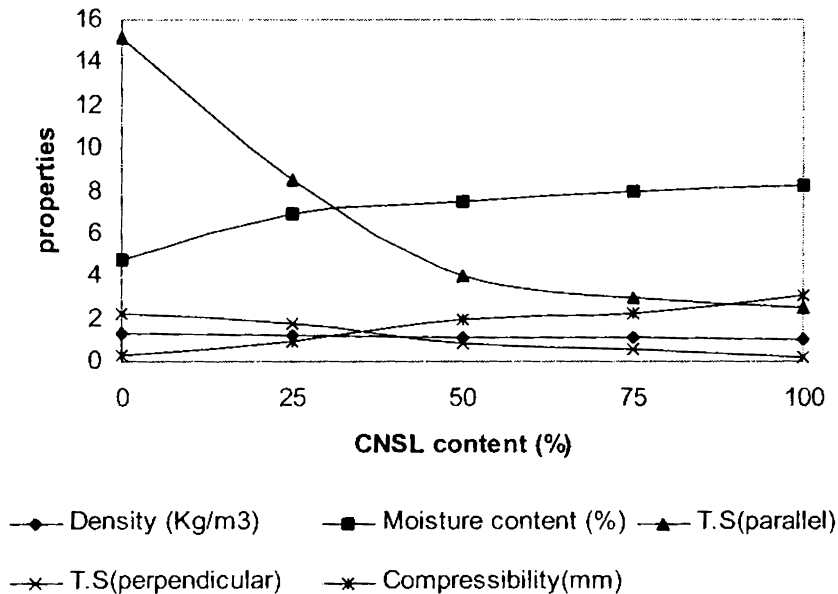

**Fig. 5.17 Variation of properties of the particleboard (Case 1) as a function of CNSL content**

Fig. 5.17 shows the variation in density, moisture content, tensile strength (parallel), tensile strength (perpendicular) and compressibility with CNSL: P ratio.

Density remains almost constant as CNSL content increases.

Moisture content increases initially as CNSL content increases.

Tensile strength (parallel) decreases sharply as CNSL content increases up to 50%. This is due to the lower reactivity of CNSL due to the presence of the long side chain of CNSL.

As the CNSL content increases bonding strength decreases. CNSL has a long side chain, which induces a plasticizing action that can improve the impact

properties but decrease the bonding strength compared to phenol. Crude CNSL also contains constituents that may not react with formaldehyde. IS specification for tensile strength (perpendicular) is a minimum of 0.8 MPa. Even at 50% CNSL there is a bonding strength of 0.8 MPa for the board. So a particleboard with good bonding strength can be obtained even after replacing 50% of phenol by CNSL.

Compressibility is seen to increase drastically with CNSL content. The presence of the substituted phenol in CNSL leads to less effective binding and consolidation. Hence compressibility increases with CNSL content. However at 50% CNSL content compressibility is not excessively high.

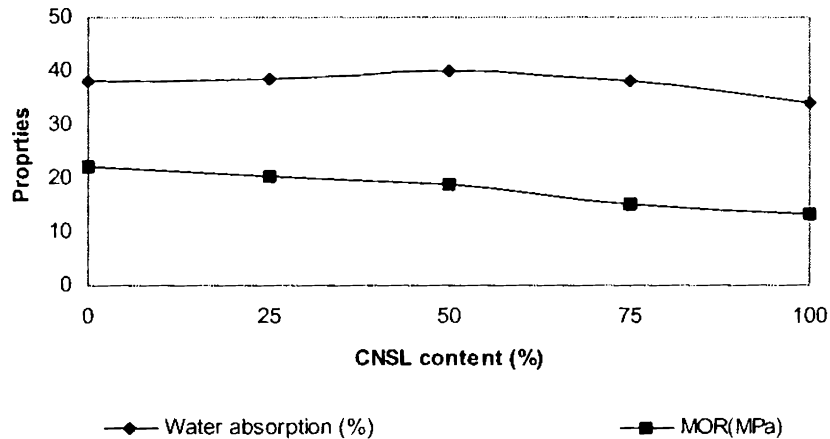

**Fig. 5.18 Variation of properties of the particleboard (Case 1) as a function of CNSL content**

MOR decreases as CNSL content increases.

There is slight decrease in water absorption with increase in resin content beyond 50%. The hydrophobicity of CNSL can be the reason behind this.

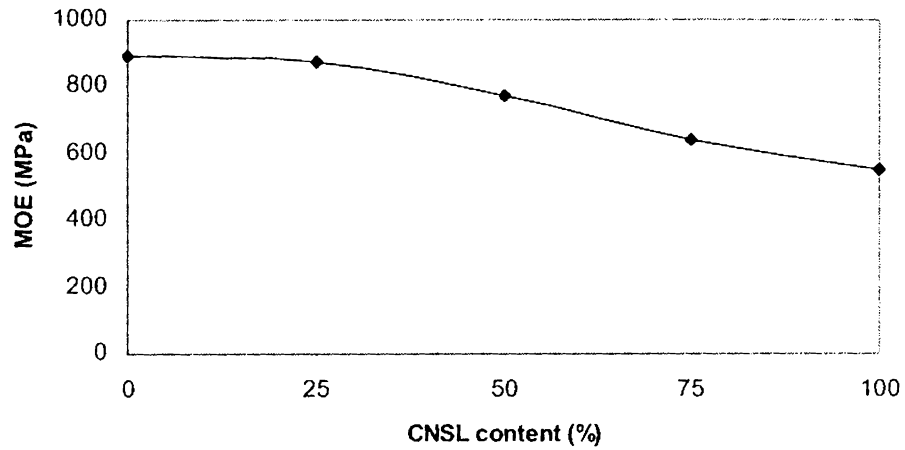

**Fig. 5.19 Variation of MOE of the particleboard (Case 1) as a function of CNSL content**

MOE decreases as CNSL content increases. At 50% CNSL there is only a small change in MOE. Hence half of phenol can be effectively replaced by CNSL.



### 5.5.2 Effect of moulding conditions and stoichiometry on the properties of particleboards from dry moulding powder consisting of CNSI-phenol- hexa copolymer (Case 2)

#### a. Effect of resin content

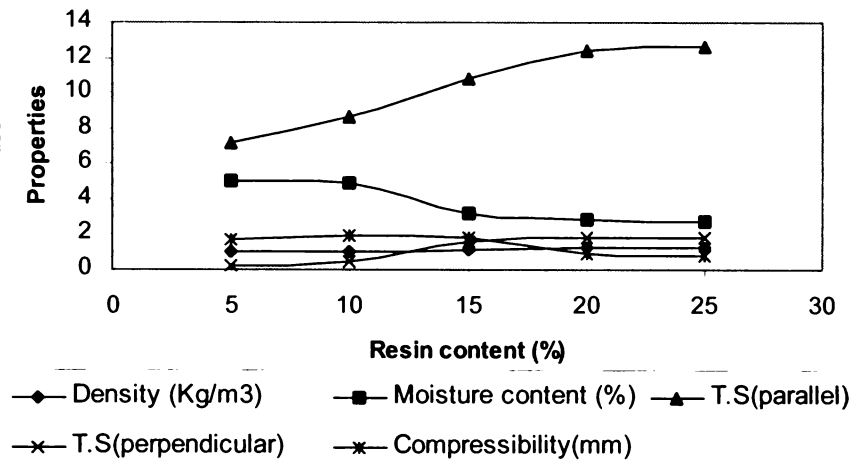

**Fig. 5.20 Variation of properties of the particleboard (Case 2) as a function of resin content**

Fig. 5.20 shows the variation of density, moisture content, tensile strength (parallel), tensile strength (perpendicular) and compressibility with resin content.

Density is almost constant when resin content varies from 5-25%.

There is a drastic fall in moisture content when the resin content varies from 10- 15%. In the higher range of resin content, 15-25%, it is almost constant.

There is an increase in tensile strength (parallel) as the resin content increases from 5 to 25%. As the resin content increases bonding between the filler particles becomes stronger and hence tensile strength increases. The values are maximum at about 25%.

Tensile strength (perpendicular) increases steadily as the resin content increases. When the resin content is about 10 phr particleboard shows tensile

strength values greater than 0.8 MPa specified by the IS 2380 (1977). It can be inferred that beyond 10% resin content a cohesive composite structure is established. At this stage a continuous bond cementing individual fibers together appears to have developed. The percentage binder required is less in this case compared to Case 1.

Compressibility decreases slightly as the resin content increases. As the bonding between the filler particles increases the free space available decreases and hence compressibility decreases.

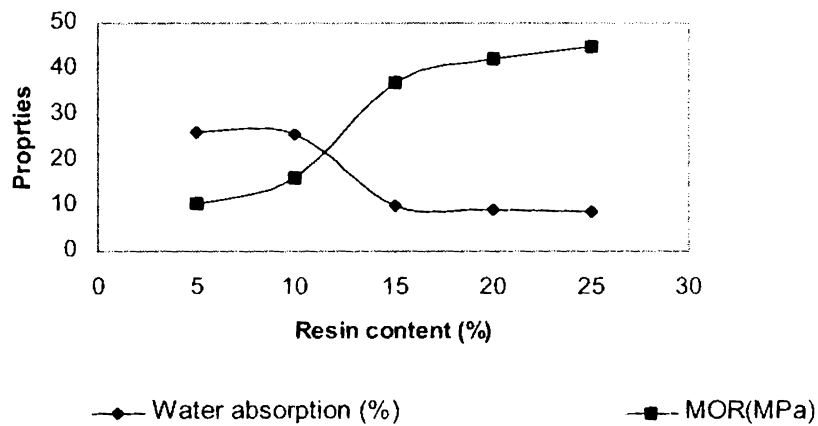

**Fig. 5.21 Variation of properties of the particleboard (Case 2) as a function of resin content**

Fig. 5.21 shows the variation in water absorption and MOR with resin content.

There is a sudden increase in MOR when the resin content increases from 10 to 15 phr. When the resin content is more than 10 phr particleboard shows values greater than the minimum value 11 MPa specified by the standard. This behaviour is similar to the case of tensile strength (perpendicular). Both graphs suggest a sudden improvement in the performance of the board beyond 10% resin content. However MOR values given in the specification is reached at as low a resin content

as 10%. Hence the board shows a superior MOR compared to conventional samples.

There is a sudden decrease in water absorption when the resin content increases from 10 to 15%. As the resin content increases there is better bonding between wood fibers. This provides less pathways for water to penetrate the composite material. It is possible that at 15% resin content, there is effective encapsulation of the fibers and closing of the capillaries.

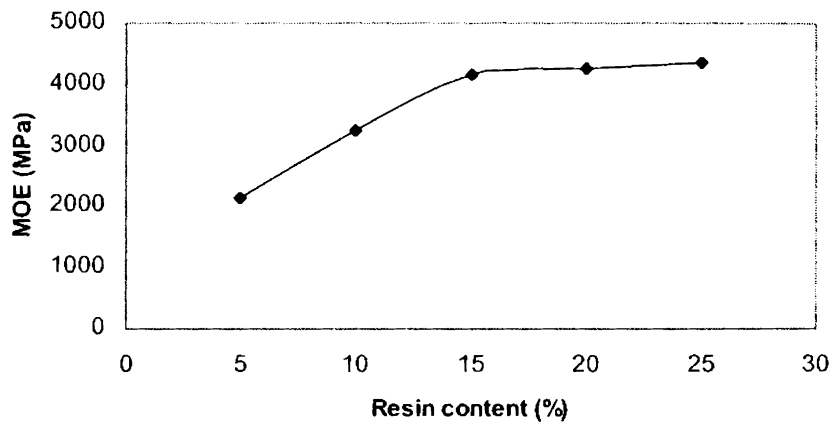

**Fig. 5.22 Variation of MOE of the particleboard (Case 2) as a function of resin content**

There is gradual increase in MOE as the resin content increases up to 15 phr. Above 15 phr resin content MOE is almost constant.

**b. Effect of P: F ratio**

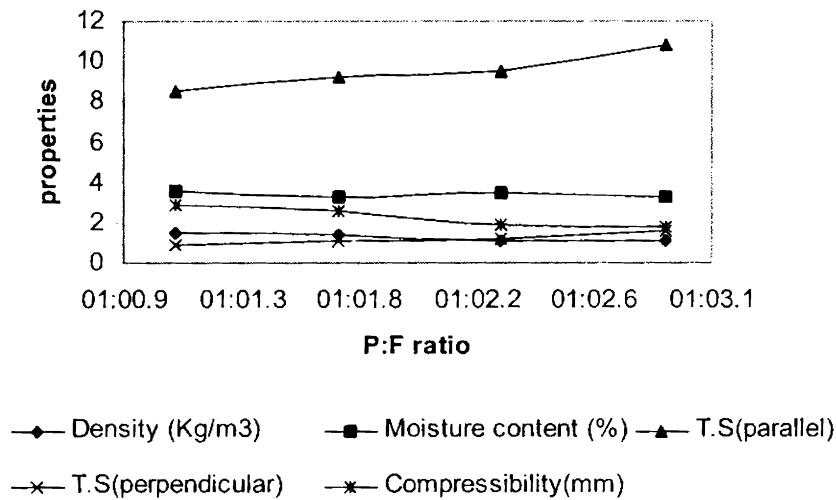

**Fig. 5.23 Variation of properties of the particleboard (Case 2) as a function of P: F ratio**

Fig. 5.23 shows the variation in density, moisture content, tensile strength (parallel), tensile strength (perpendicular) and compressibility with P: F ratio.

There is some decrease in density as the formaldehyde content increases. There is greater reduction in weight as the formaldehyde content increases due to elimination of more molecules of water of condensation.

Moisture content decreases slightly as the formaldehyde content increases.

There is a gradual increase in tensile strength (parallel) as the formaldehyde content increases. A more crosslinked and compact structure of the resin may be responsible for this. A higher formaldehyde content may lead to more effective interaction with wood fibers because of higher methylol content.

A greater tensile strength (perpendicular) is observed as the formaldehyde content goes up. This is in agreement with the observations made earlier. At higher formaldehyde content the resin has higher adhesive strength and cements the wood fibers more effectively. Higher formaldehyde content leads to a higher content of methylo groups and a greater degree of crosslinking.

Compressibility decreases as the formaldehyde increased up to about 1:2.3. There are fewer number of voids in the composite material as the formaldehyde content goes up.

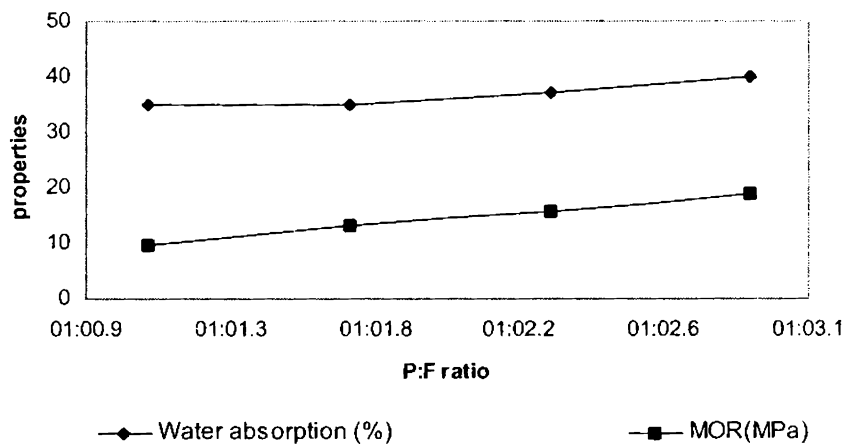
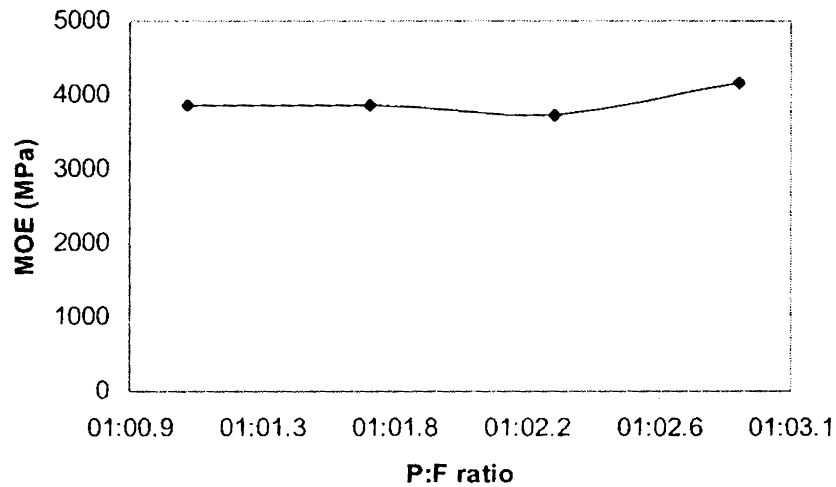

**Fig. 5.24 Variation of properties of the particleboard (Case 2) as a function of P: F ratio**

Fig. 5.24 shows the variation in water absorption and MOR with P:F ratio.

There is no variation in water absorption as the formaldehyde content changes.

There is a steady increase in MOR as the formaldehyde increases. The MOR values satisfying the Indian Standards is reached at a P: F ratio of about 1:1.7.



**Fig. 5.25 Variation of MOE of the particleboard (Case 2) as a function of P: F ratio**

Fig. 5.25 shows the variation in MOE with P: F ratio. MOE increases as the formaldehyde content increases. At the lowermost formaldehyde content studied namely 1:1.1 molecules of the condensate tends to be large. At such low formaldehyde content, methylol groups are fewer. On crosslinking a less stiff network structure is established because of lower methylol functionality. But at high formaldehyde content (> 1:2.3) a high functionality leads to a highly crosslinked network.

## c. Effect of CNSL: P ratio

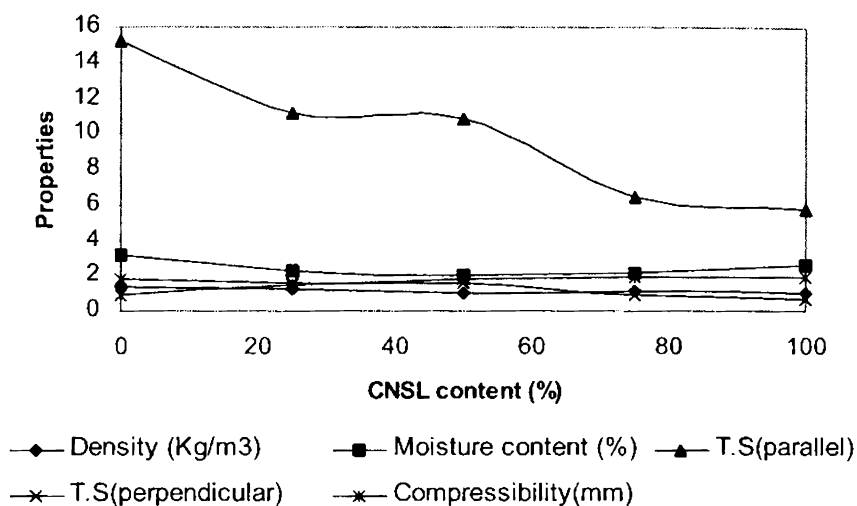

**Fig. 5.26 Variation of properties of the particleboard (Case 2) as a function of CNSL: P ratio**

Fig. 5.26 shows the variation in density, moisture content, tensile strength (parallel), tensile strength (perpendicular) and compressibility with CNSL: P ratio.

There is only a very small change in density as the CNSL content increases. Side chain of cardanol or other phenolic compounds in CNSL can lead to loose packing of the chain. The adhesive properties tend to be poorer in this case. Hence a fall in density can be expected.

Moisture content decreases as CNSL content increases. A higher percentage of CNSL leads to a higher percentages of aliphatic compounds in the form of side chain of the CNSL molecule. CNSL is more hydrophobic than phenol.

Tensile strength (parallel) decreases gradually as CNSL content increases. Particleboard based on pure CNSL- formaldehyde copolymer is about half as strong as that based on pure phenol- formaldehyde copolymer. The lower reactivity of CNSL, steric hindrance caused by side chain etc. can lead to a polymer of lower strength and binding power.

The perpendicular tensile strength or bonding strength of the resin is not seriously affected on addition of upto 20% of CNSL. Beyond 20% the strength falls drastically. Tensile strength (perpendicular) is higher than the value specified by Indian Standards when the CNSL content is less than about 50%. Considering the low cost of CNSL and its renewable nature use of CNSL can be a worthwhile proposition.

Compressibility increases marginally with CNSL content.

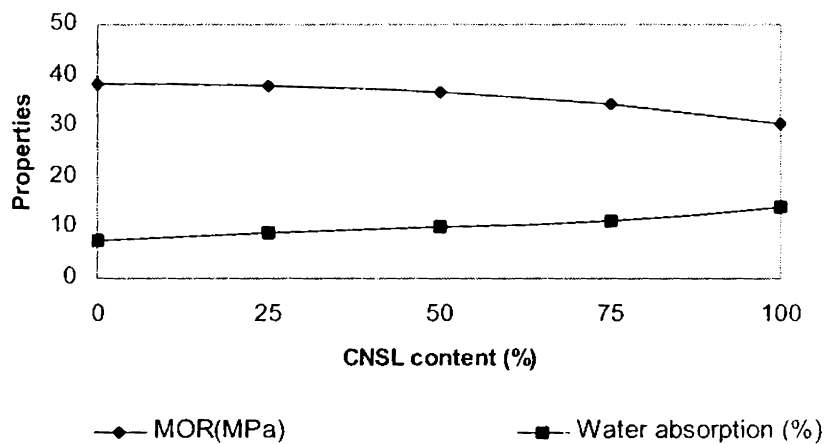

**Fig. 5.27 Variation of properties of the particleboard (Case 2) as a function of CNSL: P ratio**

Fig. 5.27 shows the variation in water absorption and MOR with CNSL: P ratio.

There is not much change in water absorption as CNSL content changes. The slightly higher water absorption indicated at higher CNSL contents may be caused by slower and possibly incomplete reaction between hexa and CNSL.

There is a small decrease in MOR as CNSL content increases. CNSL gives some flexibility to the resin.



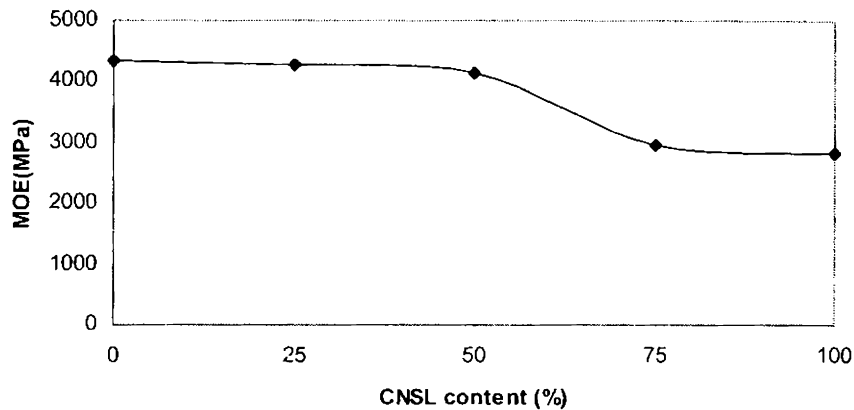

**Fig. 5.28 Variation of MOE of the particleboard (Case 2) as a function of CNSL: P ratio**

Fig. 5.28 shows the variation in MOE with CNSL: P ratio. MOE shows a slight fall on addition of more and more CNSL. Here also the lower modulus may be the result of a more flexible resin resulting from the presence of CNSL.

### 5.5.3 Effect of fillers

Table 5.3 shows comparison of properties of particleboards made from CNSL-phenol-hexa resin using different fillers (resin content – 15 phr, cure time 15 minutes, cure pressure 13.72MPa, cure temperature 150°C, CNSL/P – 50/50, P: F 1:2.9). Board made from rice husk has comparable values of tensile strength (perpendicular). Rice husk leads to a board of much lower density than that made from sawdust. Rice husk board has a much lower tensile strength (parallel) while tensile strength (perpendicular) is only marginally less. MOE and MOR are both very low compared to sawdust board.

**Table 5.3**

**Comparison of properties of particleboards made from CNSL –phenol- hexa resin using different fillers (resin content – 15 phr, cure time 15 minutes, cure pressure 13.72MPa, cure temperature 150<sup>0</sup>C, P/F – 50/50)**

| Filler       | Density<br>gm/cc | Moisture<br>Content<br>(%) | Water<br>absorption<br>(%) | Tensile<br>Strength<br>Parallel<br>(MPa) | Tensile<br>Strength<br>Perpendicular<br>(MPa) | MOR<br>(MPa) | MOE<br>(MPa) | Compres-<br>sibility |
|--------------|------------------|----------------------------|----------------------------|--|---|--------------|--------------|----------------------|
| Sawdust      | 1.06             | 3.23                       | 10                         | 10.8                                     | 1.2   | 36.9         | 4156         | 0.98                 |
| Rice<br>husk | 0.243            | 8.88                       | 16.4                       | 2.2                                      | 0.9   | 8.92         | 695          | 3.066                |

Table 5.4 shows comparison of properties of particleboards made from CNSL –phenol- hexa resin and CNSL-hexa resin (resin content – 15 phr, cure time 15 minutes, cure pressure 13.72MPa, cure temperature 150<sup>0</sup>C, CNSL/P – 50/50, P: F 1:2.9). Particleboard moulded from CNSL-phenol-hexa resin shows lower moisture content, water absorption and compressibility and higher tensile strength (parallel), tensile strength (perpendicular), MOR and MOE compared to particleboard moulded using CNSL-hexa resin.

**Table 5.4**  
**Comparison of properties of particleboards made from CNSL –phenol- hexa resin and CNSL-hexa resin (resin content – 15 phr, cure time 15 minutes, cure pressure 13.72MPa, cure temperature 150<sup>0</sup>C, P/F – 50/50)**

| Resin       | Density gm/cc | Moisture Content (%) | Water absorption (%) | Tensile Strength Parallel (MPa) | Tensile Strength Perpendicular (MPa) | MOR (MPa) | MOE (MPa) | Compressibility |
|-------------|---------------|----------------------|----------------------|---------------------------------|--------------------------------------|-----------|-----------|-----------------|
| CNSL-P-hexa | 1.16          | 3.2                  | 10                   | 10.8                            | 1.6                                  | 36.9      | 4156      | 1.803           |
| CNSL-hexa   | 1.11          | 8                    | 40                   | 4                               | 0.8                                  | 18.92     | 774       | 1.983           |

## 5.6 CONCLUSIONS

The mould design and the moulding procedure adopted for particleboard moulding by both the methods (Case 1 and Case 2) are found to be effective. This can be a starting point for a moulding process to make larger mouldings.

The cure temperatures studied (150, 160, 170, 180 and 190<sup>0</sup>C) are found to affect the properties of the board only marginally. The overall picture favors a cure temperature of 150<sup>0</sup>C. Most properties are optimal at about 15 minutes cure time. The resin content affects the tensile strength (perpendicular) drastically. It shows acceptable values at any resin content beyond 15% when a binder consisting of a reactive mixture of CNSL and hexa is used. A P: F ratio of 1: 2.9 is required to give sufficiently high values of bonding strength. There is a slow but steady increase in tensile strength (perpendicular) as the formaldehyde content increases. The presence of CNSL lowers the tensile strength values. But about 50% CNSL can be used to replace phenol to give a board with acceptably high values of bonding strength. In general, CNSL content increases the compressibility of the board.

A resin content of 10% gives sufficiently high values of bonding strength and acceptable values of water absorption when the powdered resin resulting from

the condensation of CNSL, phenol and hexa is used. Both MOR and MOE reach a plateau at 15% resin content. The P: F ratio has very little effect on the bonding strength which is uniformly high. Increasing CNSL content leads to a board of lower tensile strength but the bonding strength is still high upto 50% CNSL content in a mixture of CNSL and phenol used for the binder.

## REFERENCES

1. H. Kubler, Wood as a building and hobby material, Wiley and Sons, Inc., Canada (1977).
2. A.Knop, W.Scheib, Chemistry and Application of Phenolic resins, Springer-Verlag, New York (1979).
3. R. Viswanathan, L.Gothandapani, Bioresource Technology, 67(1), 93-95 (1999).
4. A. Sampathrajan, N.C.Vijayaraghavan, K.R.Swaminathan, Bioresource Technology, 35 (1), 67-71 (1999).
5. A. Sampathrajan, N.C.. Vijayaraghavan, K.R.Swaminathan, Bioresource Technology, 40 (3), 249-251 (1992).
6. P. Khristova, S.Gabir, Bioresource Technology, 58 (3), 319-321 (1996).
7. E.G. Jan, J.A. Martin and R.P.Edwin, Industrial crops and products, 20 (1), 97-101 (2004).
8. A.N. Papadopoulos, C.A.S Hill, A. Gkaraveli, G.A Ntalos, European Journal of wood and wood products (2004)
9. A.N. Papadopoulos, J.B. Hague, Ind. Crops and Products, 17(2), 143-147 (2003)
10. IS: 840 (1964)
11. K.V. Sarkanen, C.W. Ludweg,, Lignins, Wiley- Intersciences, New York (1971)
12. W. Alfred, Wood and Fiber Science, 23(1), 69-74 (1991)
13. H.T.Wegner, United States Department of Agriculture, in Encyclopedia of Polymer Science and Engineering, Vol 17, A Wiley Interscience Publication, U.S.A (1985).
14. B. English, J.A. Youngquist and A.M. Krzysik, Lingnocellulosic Composites, In: R.D. Gilbert Ed. Cellulosic Polymers, Blends and Composites, New York, Hanser Publishers, 115-130, 1994, Ch. 6

# Chapter 6

## CONCLUSIONS

---

The important conclusions from the study are the following

1. CNSL, phenol and formaldehyde can be co-condensed to get a CNSL-phenol- formaldehyde resole resin with a typical  $\bar{M}_n = 835$  and  $\bar{M}_w = 3345$ . Melting point is in the range of 70 to 80<sup>0</sup>C and a typical decomposition temperature is 500<sup>0</sup>C.
2. Of the two methods for preparation of resin investigated, the method involving a condensation step followed by air-drying for 4 days is more acceptable because it gives a shorter cure time subsequently.
3. Useful adhesive systems based on neoprene and CNSL –phenol-hexa copolymer can be formulated. Such adhesives are more suitable for Al- Al bonding rather than IIR-Al or IIR-IIR bonding.
4. Cure time of 2.5 hours and a cure temperature 140<sup>0</sup>C are found to give the best results for these adhesives.
5. The resin used for adhesive formulation is found to give the best performance at 45 to 55 phr of the resin and a total phenol: formaldehyde ratio of 1:2.9. Total solid content of the formulation is optimum at 38 %
6. A coupling agent 3- aminopropyl triethoxy silane is found to improve the performance of Al- Al adhesive bonds.
7. The best results are obtained for the resin resulting from condensation of pure phenol with formaldehyde. However inclusion of upto 25% CNSL gives an almost equivalent performance.
8. The copolymer obtained by condensation of CNSL and phenol with hexa when added at the rate of 15 phr improves the ageing characteristics of NBR, SBR and IIR with respect to retention in tensile strength, modulus, tear strength and elongation at break. All these rubbers behave in a similar fashion in this respect.

9. Vulcanizates containing resin with P: F ratio 1: 2.9 shows the least change in properties on ageing.
10. Although resin based on pure phenol gives the greatest improvement in ageing characteristics of NBR, addition of CNSL upto 25% still resulted in substantial improvement.
11. Based on studies of SBR, CNSL by itself at 15 phr has the ability to improve the ageing characteristics.
12. Ageing studies on EPDM and NR show no positive effect on addition of CNSL- phenol- hexa resin. In the case of CR which has inherent resistance to ageing no effect is noticeable.
13. The mould design and moulding procedure adopted for particleboard moulding are found to be effective. This can be a starting point for a moulding process to make larger mouldings.
14. When a binder consisting of a reactive mixture of CNSL and hexa is employed a minimum resin content of 15% is needed for optimum performance of particleboard.
15. For particleboard based on rosewood sawdust and CNSL based resin, the optimum cure temperature is 150<sup>0</sup>C and cure time, 15 minutes.
16. When a reactive mixture of CNSL and hexa is used as the binder a high formaldehyde content (P: F ratio 1:2.9) is needed. But when the powdered resin is used as the binder even low formaldehyde content typically 1:1.1 gives adequate bonding strength. In both cases replacement of phenol to the extent of 50% by CNSL gives an equivalent performance by the particleboard.
17. When a powdered resin resulting from the condensation of CNSL, phenol and hexa is used as binder 10% resin concentration gives the accepted values of bonding strength for the board.
18. The study amply demonstrates the utility of CNSL for three important applications in polymer processing.

## *List of abbreviations and symbols*

---

|                                |   |  |
|--------------------------------|---|--|
| ANSI                           | - | American National Standards Institute      |
| ASTM                           | - | American Society for Testing and Materials |
| CNSL                           | - | Cashew nut shell liquid                    |
| cp                             | - | Centipoise                                 |
| CR                             | - | Chloroprene rubber                         |
| DBP                            | - | Di butyl phthalate                         |
| DCPD                           | - | Dicyclopentadiene                          |
| DIN                            | - | Deutsches Institut für Normung             |
| DOP                            | - | Di octyl phthalate                         |
| DSC                            | - | Differential scanning calorimetry          |
| ENB                            | - | Ethylidene norbornene                      |
| EPDM                           | - | Ethylene propylene diene monomer           |
| EVA                            | - | Ethyl vinyl acetate                        |
| F                              | - | Formaldehyde                               |
| GLC                            | - | Gas Liquid Chromatography                  |
| GPC                            | - | Gel Permeation Chromatography              |
| HAF                            | - | High abrasion furnace black                |
| HCHO                           | - | Formaldehyde                               |
| HMTA                           | - | Hexamethylenetetramine                     |
| HPLC                           | - | High Permeation Liquid Chromatography      |
| H <sub>2</sub> SO <sub>4</sub> | - | Sulphuric acid                             |



## *Abbreviation*

---

|                             |   |  |
|-----------------------------|---|--|
| IS                          | - | Indian Standards   |
| IIR                         | - | Isobutylene-isoprene rubber  |
| KMnO <sub>4</sub>           | - | Potassium permanganate   |
| MBTS                        | - | Mercaptobenzothiazol disulphide  |
| min                         | - | Minutes  |
| mm                          | - | millimetre   |
| MF                          | - | Melamine formaldehyde  |
| MgO                         | - | Magnesium oxide  |
| MPa                         | - | Mega pascals   |
| MT                          | - | Metric ton   |
| $\bar{M}_n$                 | - | Number average molecular weight  |
| $\bar{M}_w$                 | - | Weight average molecular weight  |
| $\bar{M}_v$                 | - | Viscosity average molecular weight   |
| ML (1+4) 100 <sup>0</sup> C | - | Mooney viscosity number. L indicates the large rotor, 1 is the time in minutes that the specimen is preheated, 4 is the time in minutes after starting the motor at which the reading is taken, and 100 <sup>0</sup> C is the temperature of the test. |
| MOE                         | - | Modulus of elasticity  |
| MOR                         | - | Modulus of rupture   |
| MPa                         | - | Mega pascls  |
| N                           | - | Newton   |
| NaOH                        | - | Sodium hydroxide   |

|                                 |   |                                 |
|---------------------------------|---|---------------------------------|
| NBR                             | - | Acrylonitrile- butadiene rubber |
| NR                              | - | Natural rubber                  |
| P                               | - | Phenol                          |
| Pa                              | - | Pascals                         |
| PF                              | - | Phenol formaldehyde             |
| Phr                             | - | Per hundred rubber              |
| PTSA                            | - | Paratoluenesulphonic acid.      |
| PVC                             | - | Polyvinyl chloride              |
| PVAc                            | - | Poly(vinyl acetate)             |
| SBR                             | - | Styrene- butadiene rubber       |
| SO <sub>2</sub> Cl <sub>2</sub> | - | Sulfonyl dichloride             |
| TLC                             | - | Thin Layer Chromatography       |
| TGA                             | - | Thermogravimetric analysis      |
| TMTD                            | - | Tetramethylthiuram disulphide   |
| UF                              | - | Urea formaldehyde               |
| UTM                             | - | Universal Testing Machine       |
| UV                              | - | Ultraviolet                     |
| wt                              | - | Weight                          |
| ZnO                             | - | Zinc oxide                      |

## *List of Publications*

---

1. "Cashew Nut Shell Liquid- a versatile monomer for polymer synthesis" *Designed Monomers and Polymers*, C. Mary Lubi and Eby Thomas Thachil, Vol 3, No 2, 123-153 (2000)
2. "Modification of NBR by addition of Phenol- CNSL- Formaldehyde copolymer" *Journal of Elastomers and Plastics*, C. Mary Lubi and Eby Thomas Thachil, Vol 33, No 2, 121-136 (2001)
3. "Copolymerization of CNSL and phenol by condensation with hexamine " *International Journal of Polymeric Materials*, Mary Lubi C. and Eby Thomas Thachil, Vol 52, No 9, 793-807 (2003)
4. "Effect of Phenol- CNSL- Formaldehyde on Thermal Ageing of NBR" *Progress in Rubber, Plastics and Recycling Technology*, Mary Lubi C. and Eby Thomas Thachil, Vol 21, No 3, 201-218 (2005).
5. "Studies on metal-to-metal adhesives based on CNSL resin" *Polymer Plastic Technology and Engineering* , Vol 45, 1-6 (2006)
6. "Effect of Phenol- CNSL- Formaldehyde on Thermal Ageing of SBR" *International Journal of Polymeric Materials* (Accepted)
7. "Particleboard from Cashew Nut Shell Liquid (CNSL)" *Polymer and Polymer Composites* (Accepted).
8. "Effect of Phenol- CNSL- Formaldehyde on Thermal Ageing of Elastomers" *International Journal of Polymeric Materials* (Accepted)
9. "Effect of Phenol- CNSL- Formaldehyde on Thermal Ageing of Elastomers" *Journal of Elastomers and Plastics* (Communicated)

10. "Particleboard from Cashew Nut Shell Liquid (CNSL)" *Polymer Plastic Technology and Engineering* (Accepted)
11. "Modification of Unsaturated Polyester Resin using Elastomers," *Journal of Elastomers and Plastics*, C. Mary Lubi, K.Ravi, Abdeen Ahammed and Eby Thomas Thachil, Vol 32, 60-72 (2000).
12. "Synthesis of Unsaturated Polyester Resin- effect of anhydride ratio", *Designed Monomers and Polymers*, C.Mary Lubi, Abdeen Ahammed, M. Zafeer, and Eby Thomas Thachil, Vol 4, Issue 3, 260-267 (2001)

